

FRAMED OPENING JAMB AT
FLOOR TO EAVE STRUT
(HEADER WITH ANGLE)

SHT. NO. AC01041	
DATE FEB. 05	REV. 00

FRAMED OPENING WIDTH LESS THAN OR
EQUAL TO 7'-0"

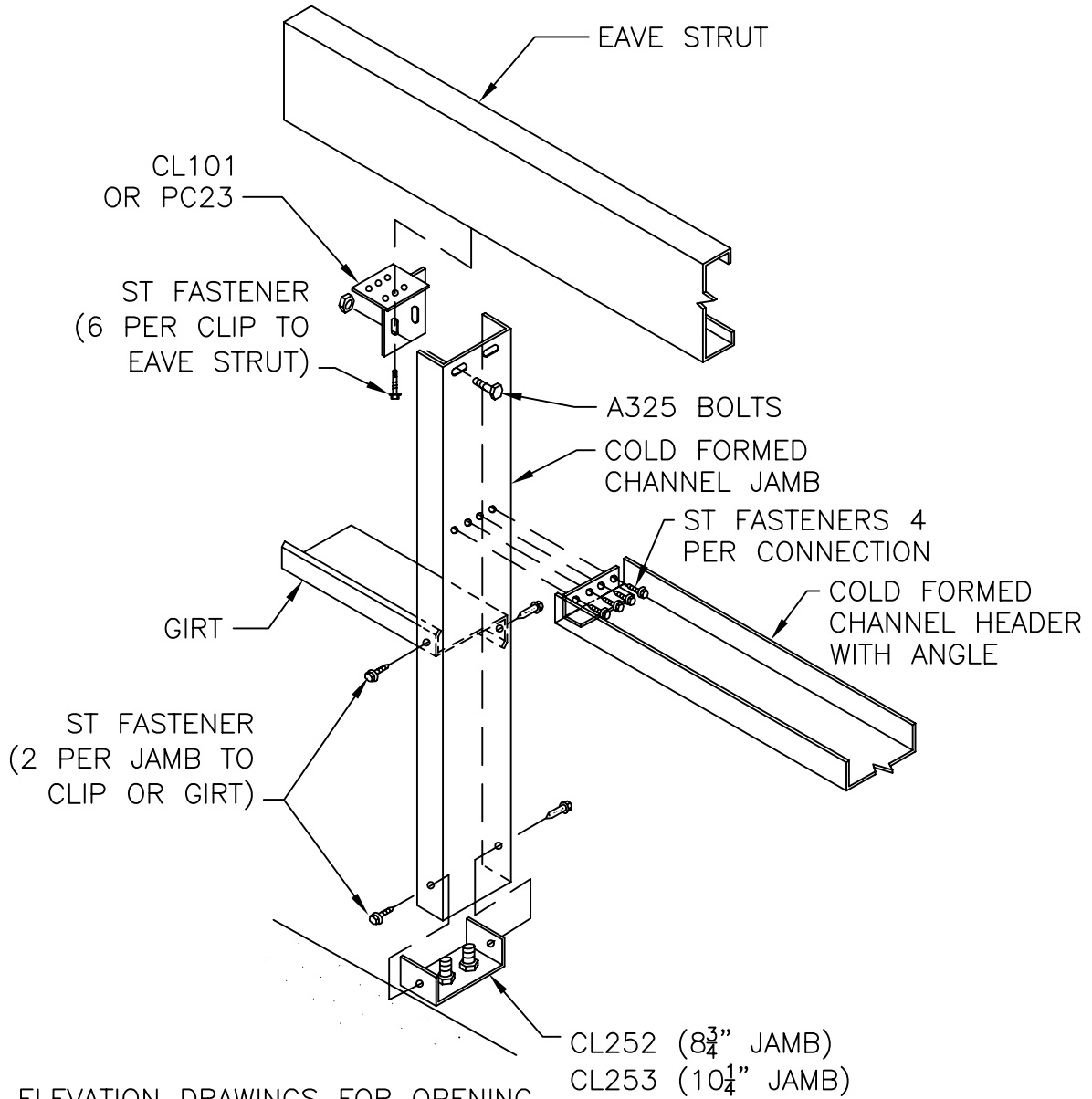

SEE ELEVATION DRAWINGS FOR OPENING
LOCATION AND PIECE MARKS.

FOUR SIDED FRAMED OPENING
JAMB AT FLOOR TO EAVE STRUT
(HEADER AND SILL WITH CL100)

SHT. NO. AC01042	
DATE FEB. 05	REV. 00

FRAMED OPENING WIDTH GREATER THAN 7'-0"

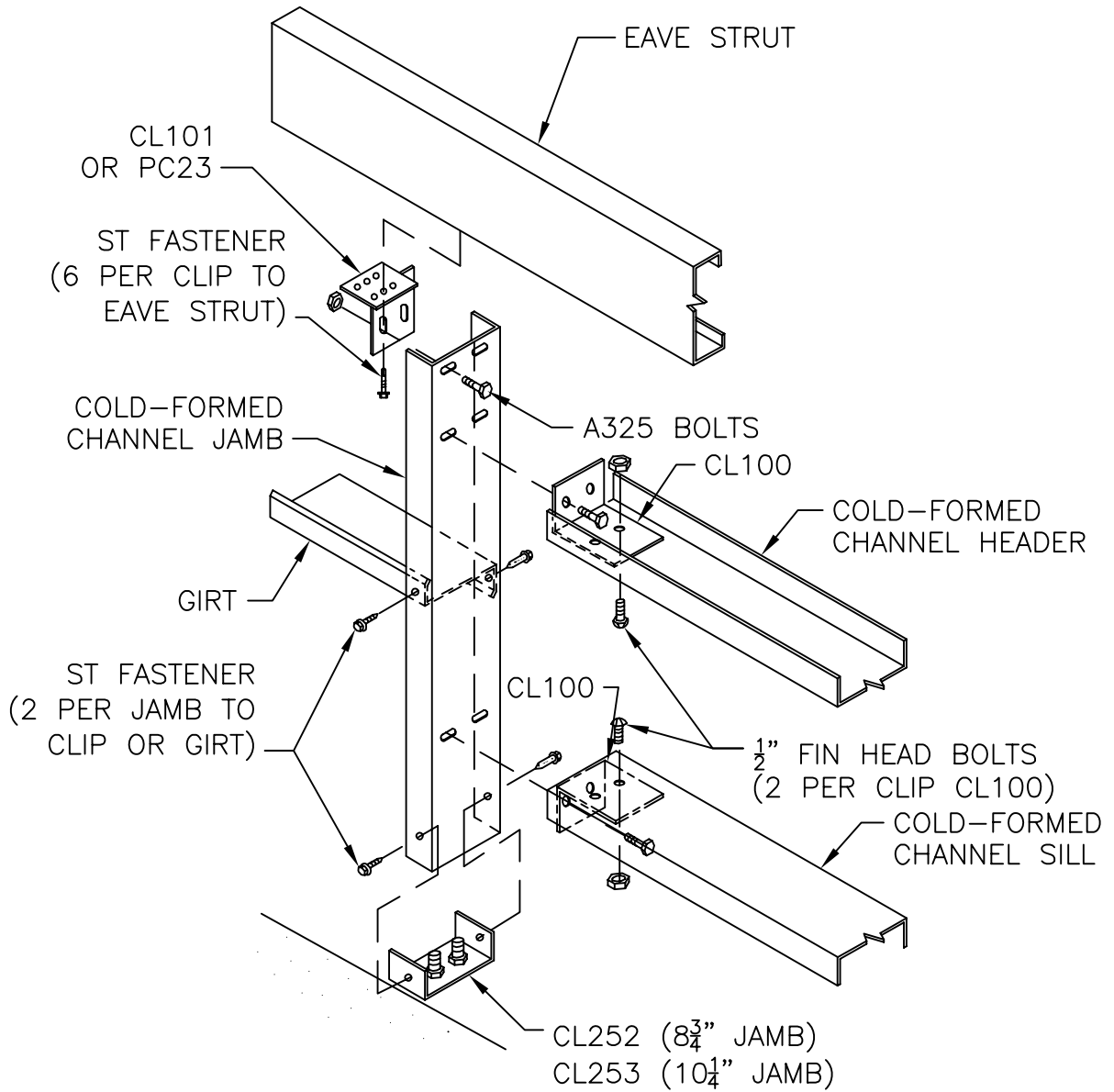

SEE ELEVATION DRAWINGS FOR OPENING
LOCATION AND PIECE MARKS.

FOUR SIDED FRAMED OPENING
 JAMB AT FLOOR TO EAVE STRUT
 (HEADER AND SILL WITH ANGLE)

SHT. NO. AC01043	
DATE FEB. 05	REV. 00

FRAMED OPENING WIDTH LESS THAN OR
 EQUAL TO 7'-0"

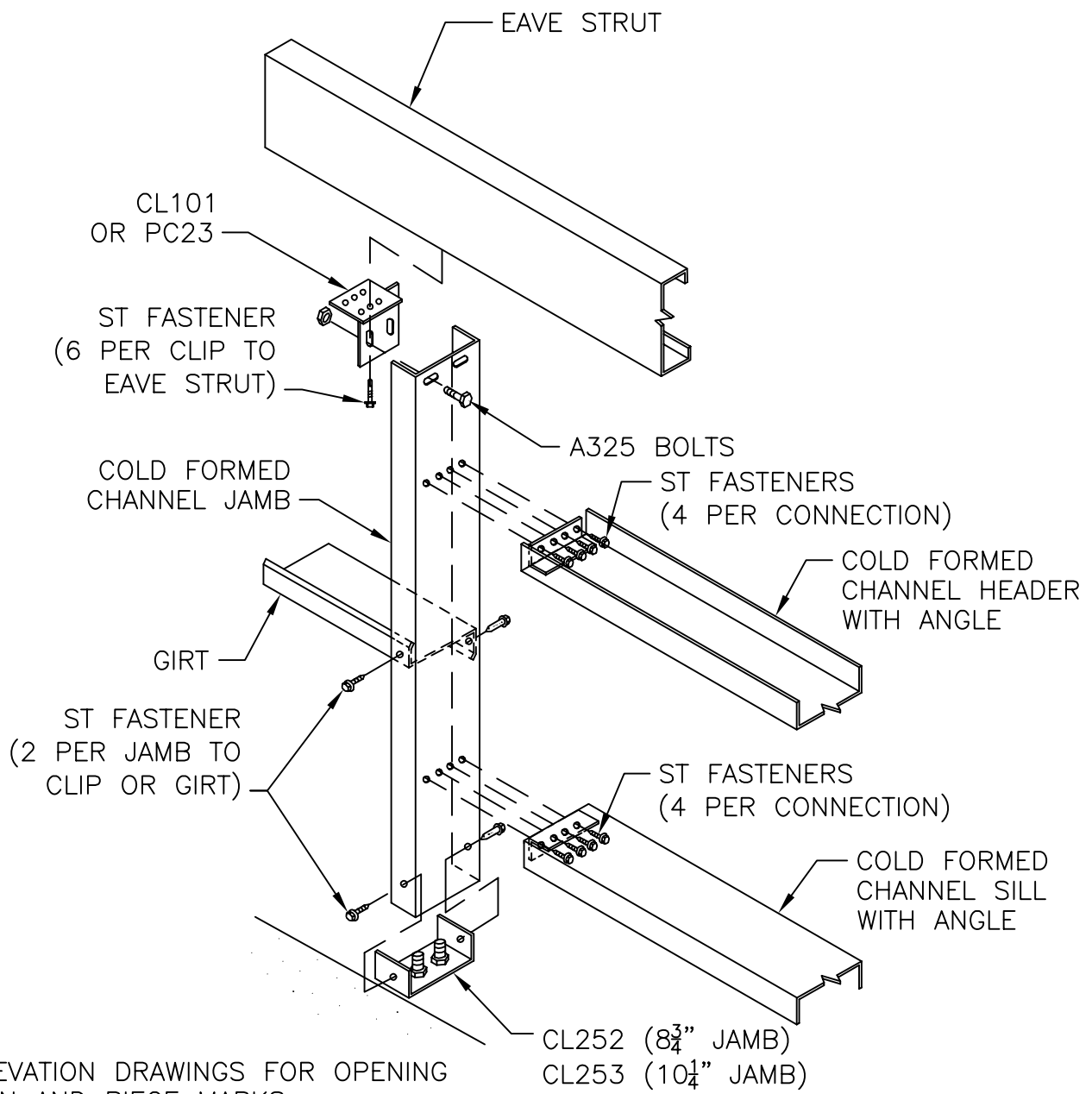

SEE ELEVATION DRAWINGS FOR OPENING
 LOCATION AND PIECE MARKS.

FRAMED OPENING JAMB AT FLOOR
TO GIRT (HEADER WITH CL100)

SHT. NO. AC01044	
DATE FEB. 05	REV. 00

FRAMED OPENING WIDTH GREATER THAN 7'-0"

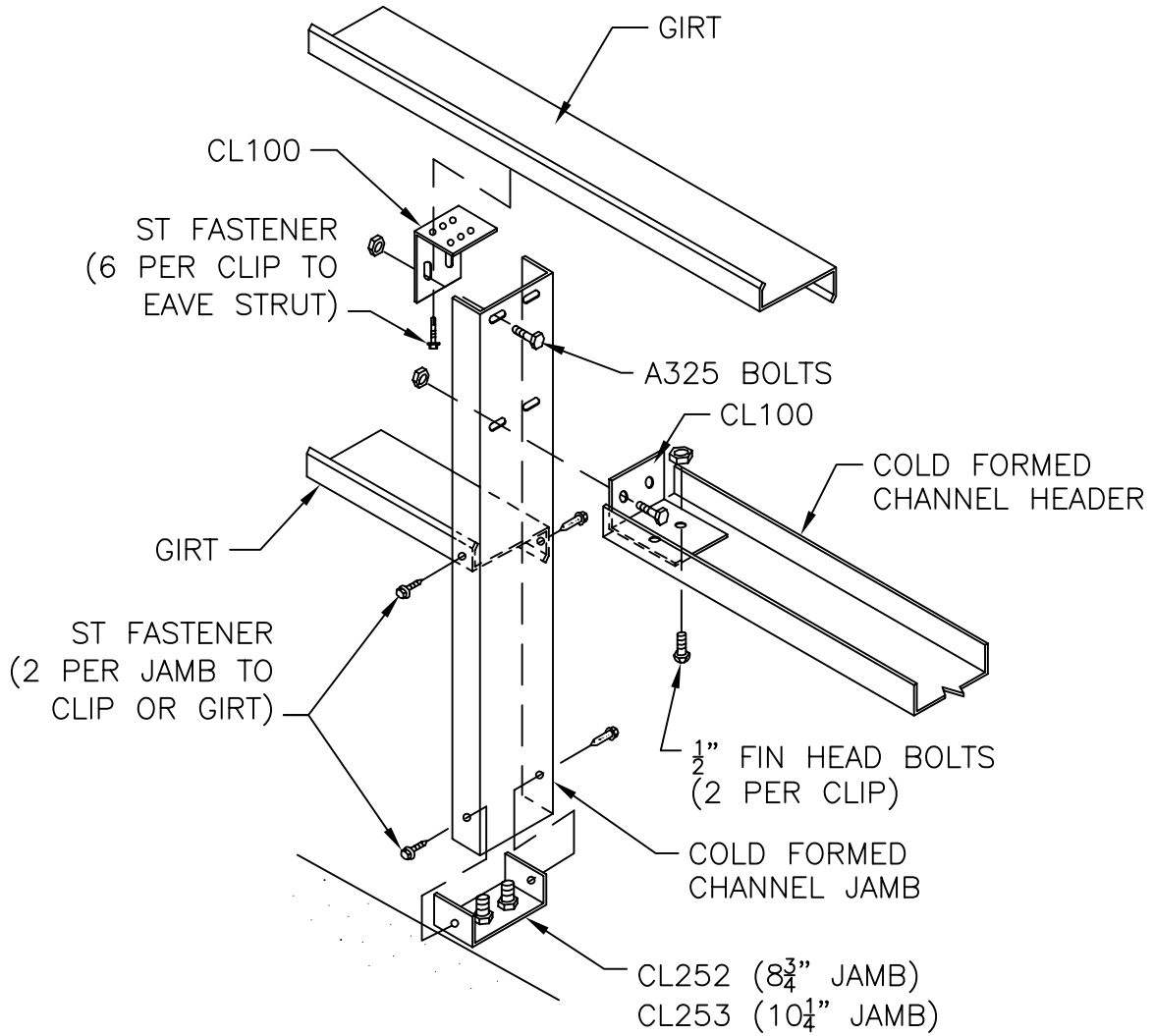

SEE ELEVATION DRAWINGS FOR OPENING
LOCATION AND PIECE MARKS.