

WALL BASE WITH RECESS

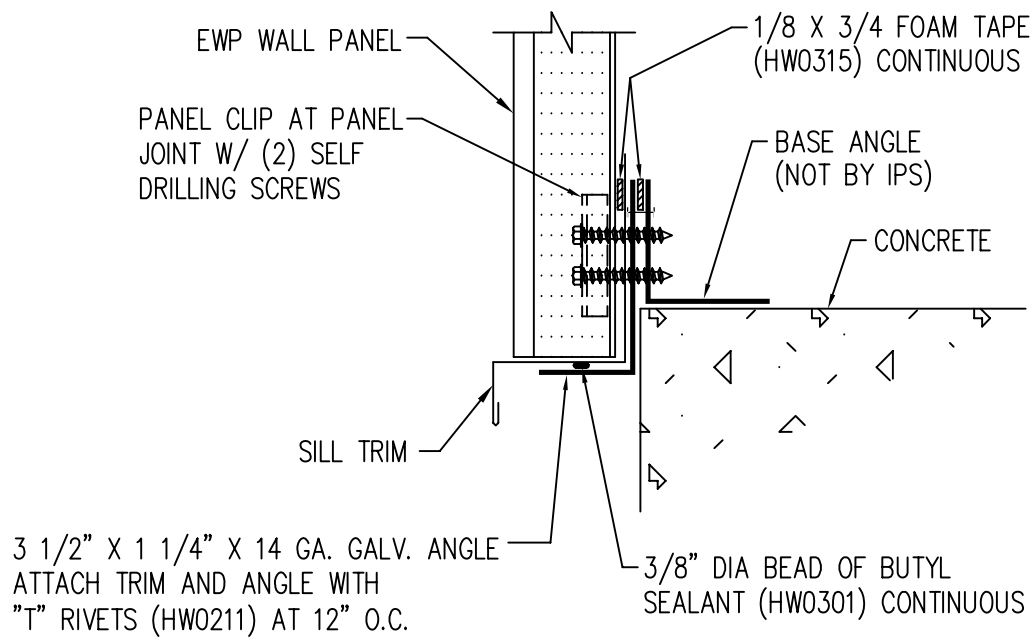

WALL BASE WITHOUT RECESS

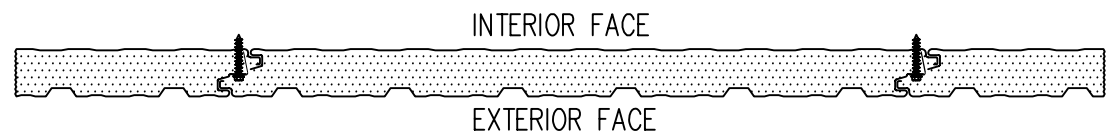
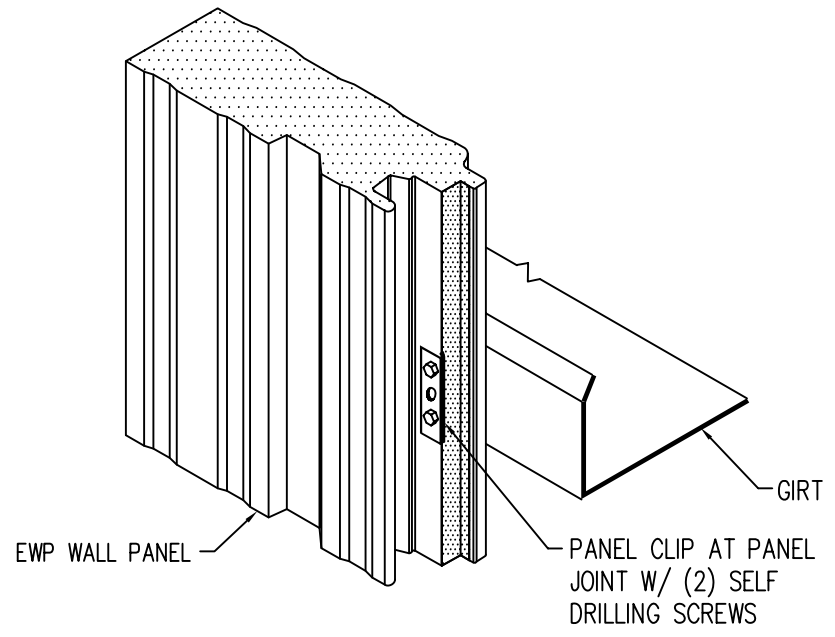

GIRT DETAIL W/ COLD FORMED ZEE

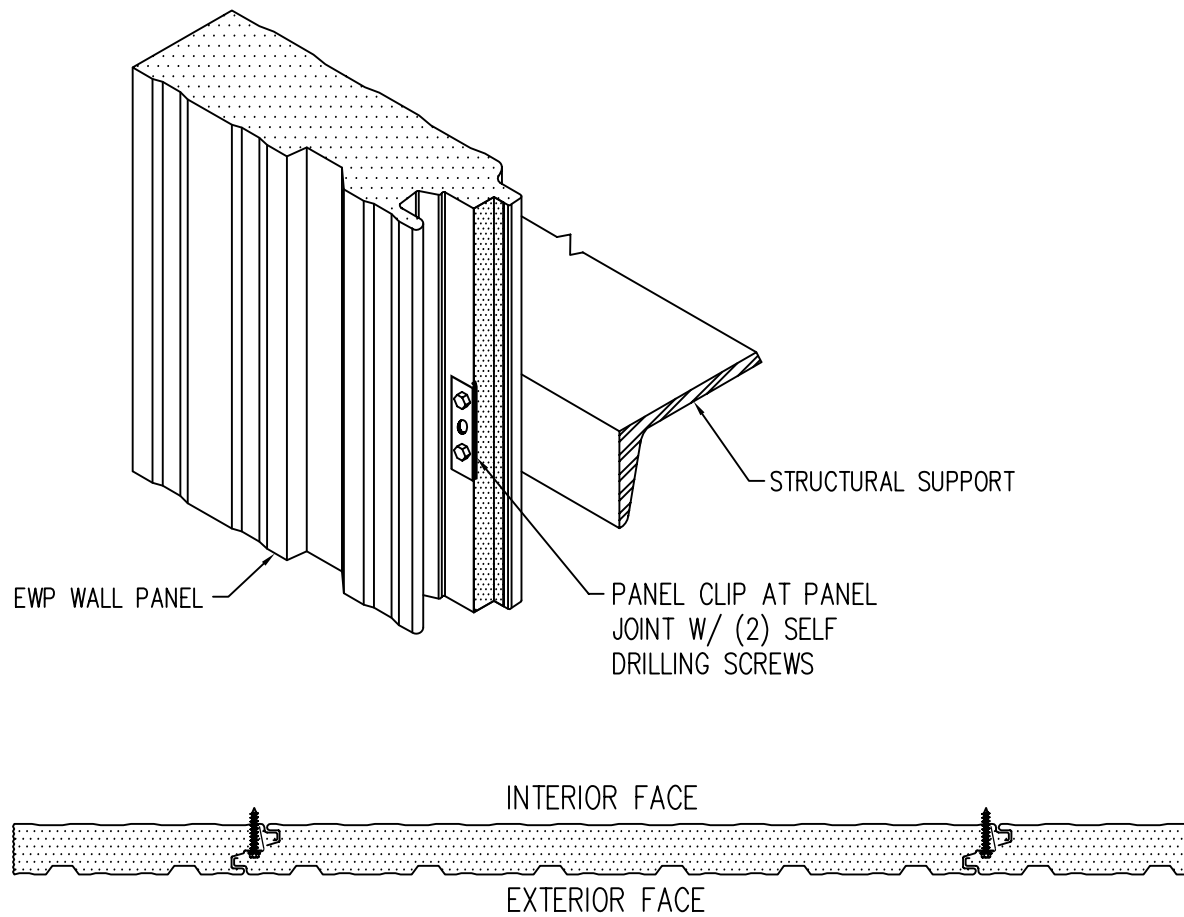

GIRT DETAIL W/ HOT ROLLED MEMBER

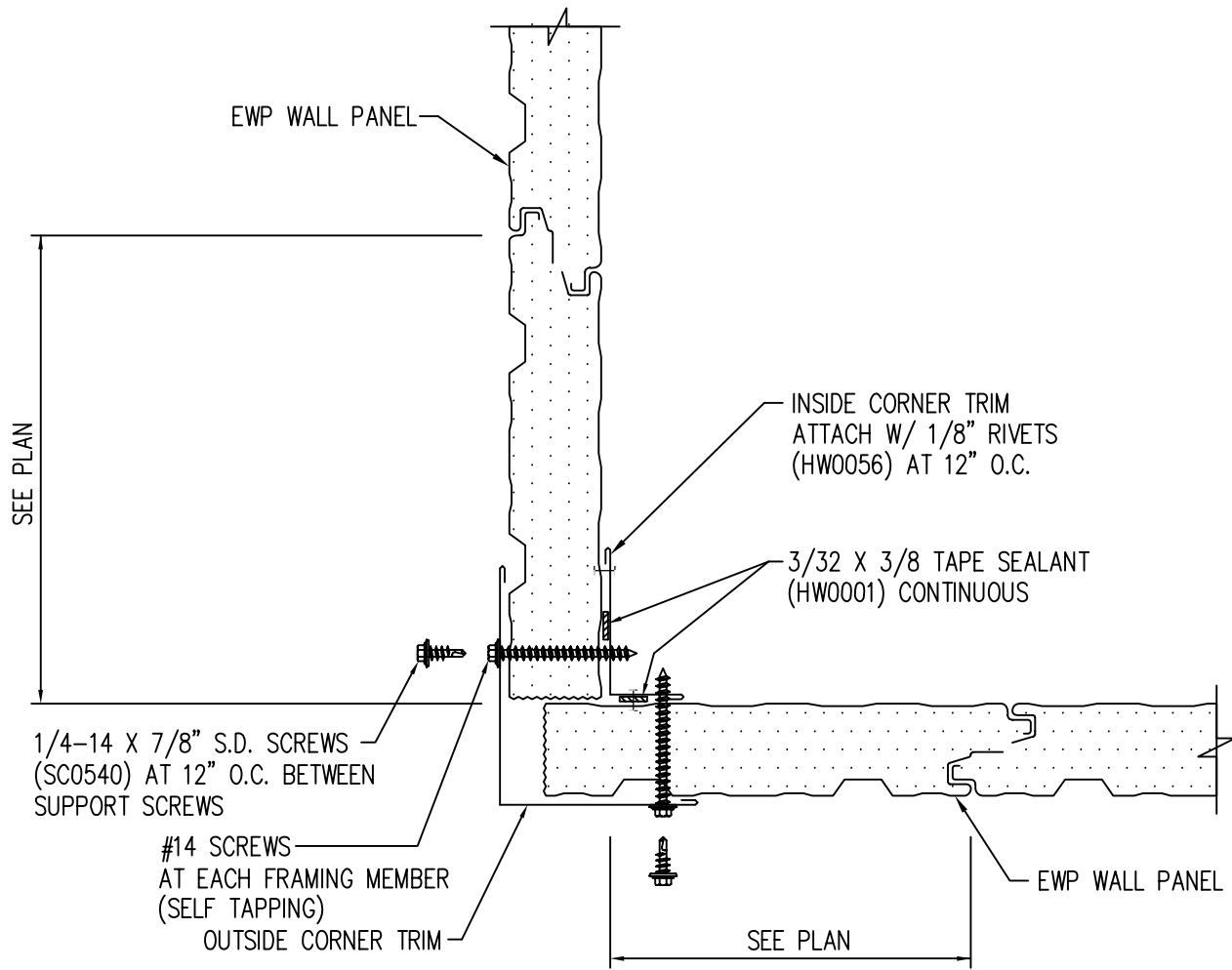

OUTSIDE CORNER

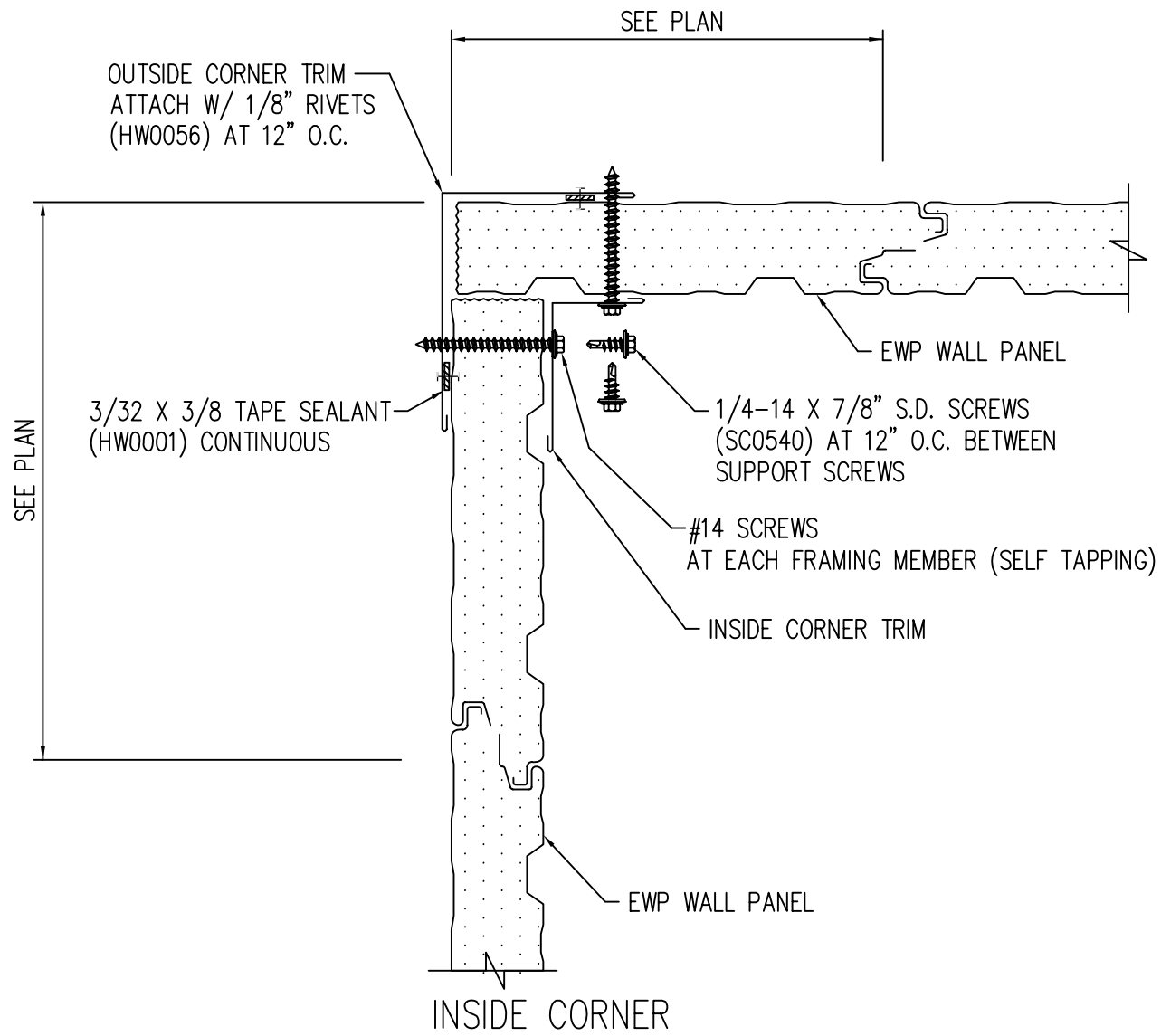

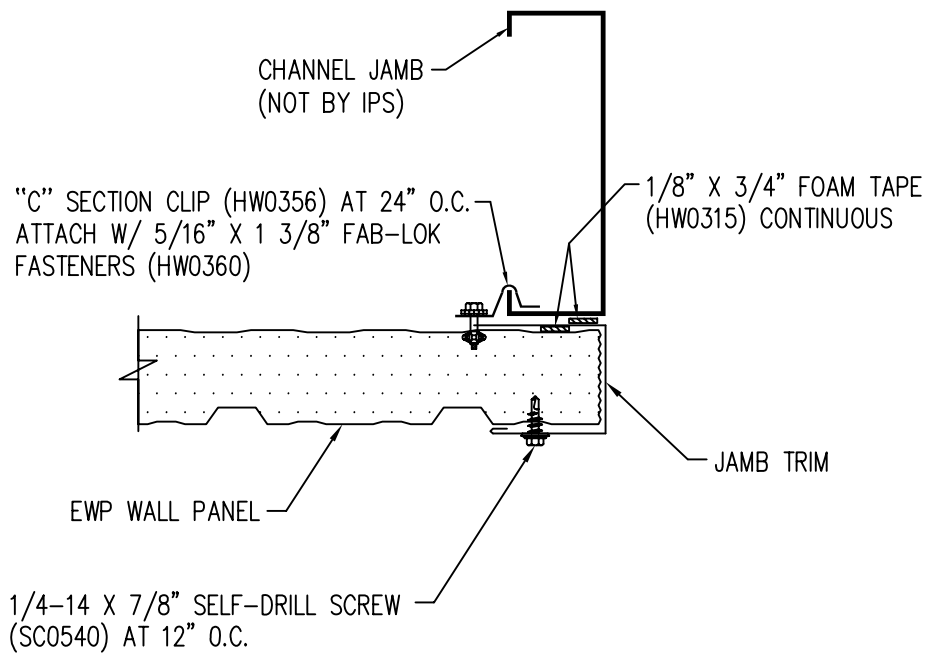

JAMB DETAIL AT OVERHEAD DOOR

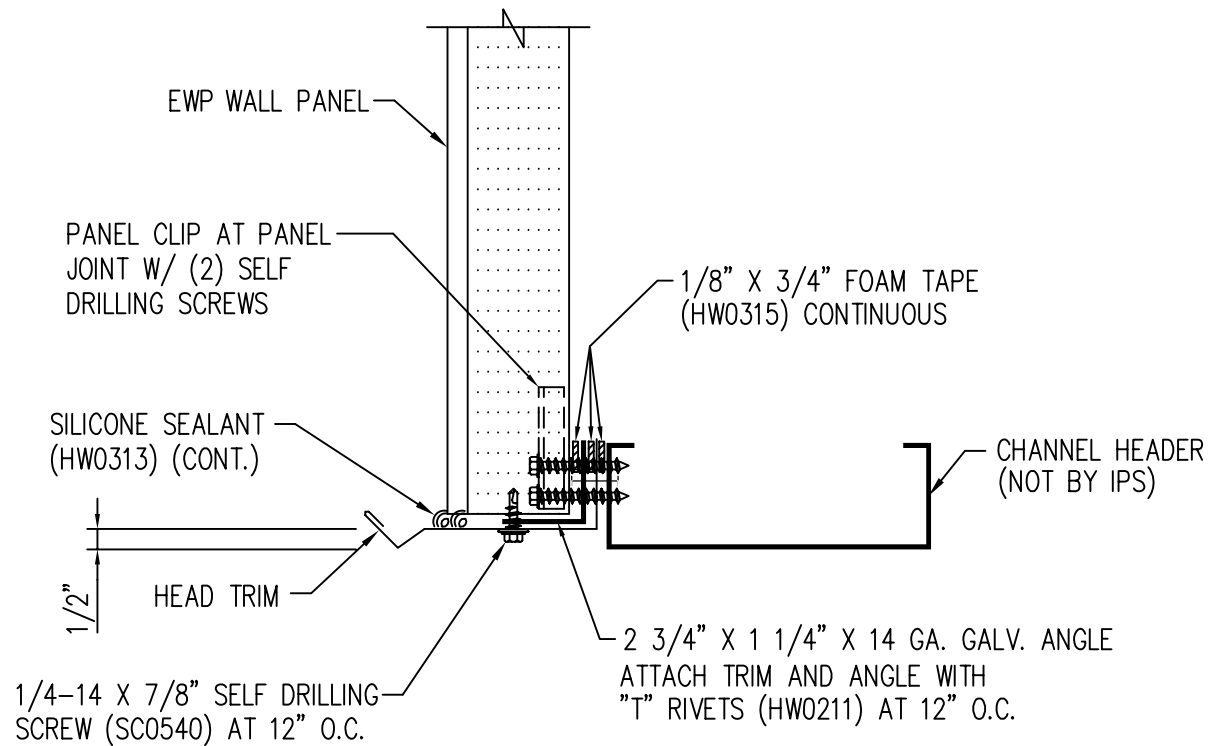

HEAD DETAIL AT OVERHEAD DOOR

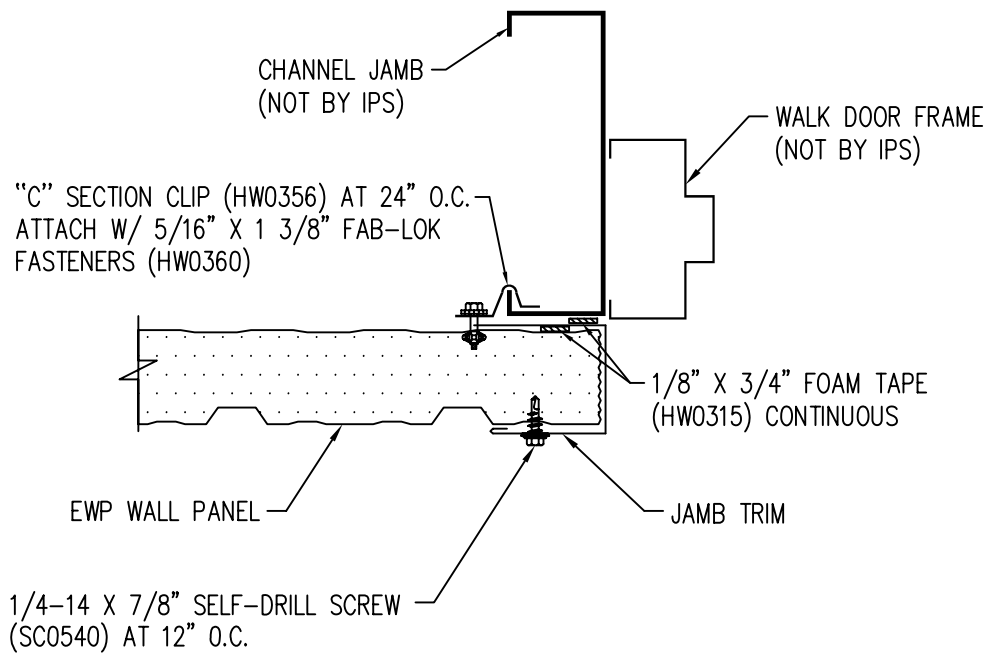

JAMB DETAIL AT WALK DOOR

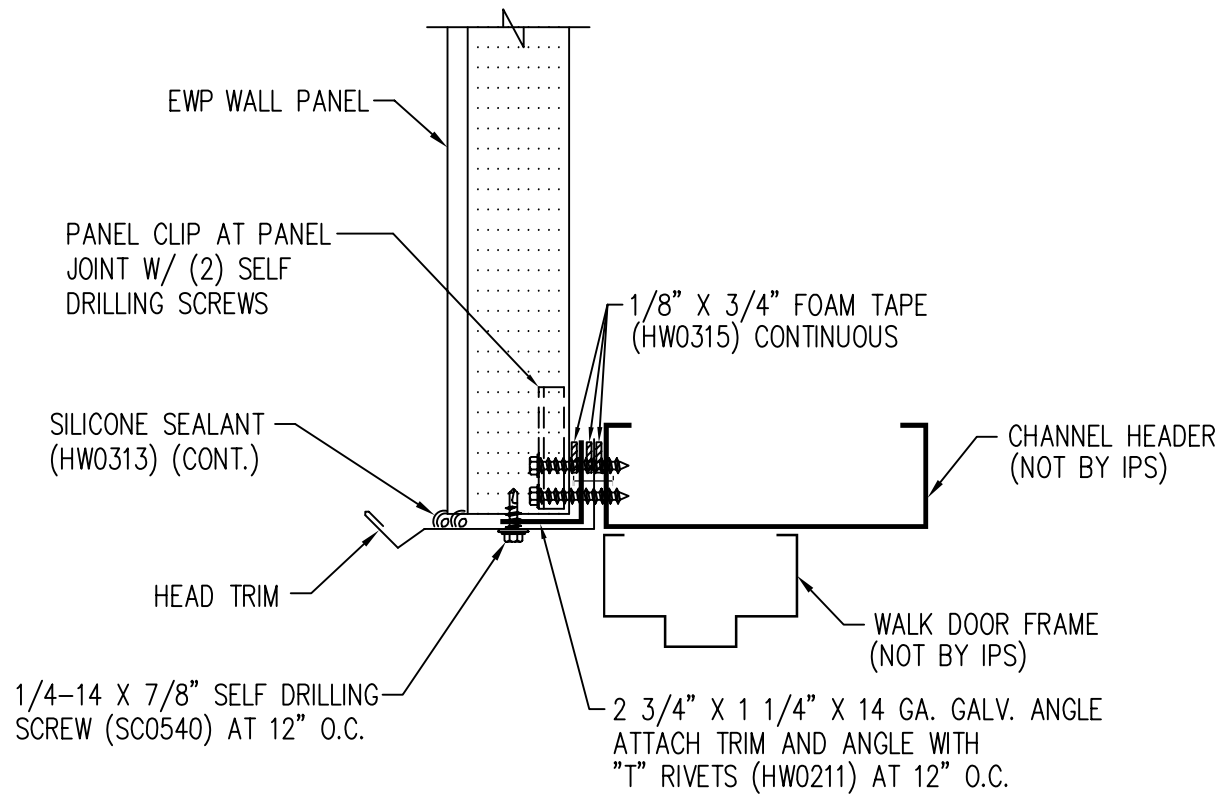

HEAD DETAIL AT WALK DOOR

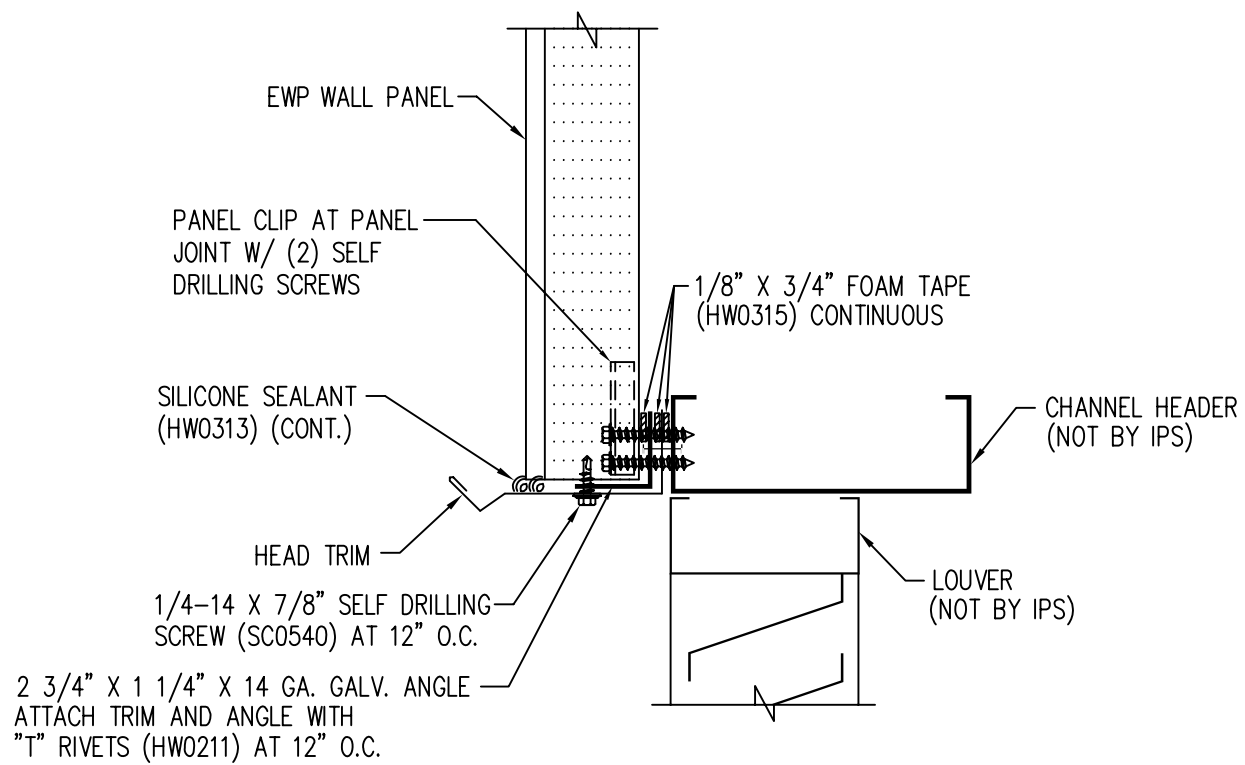

HEAD DETAIL AT LOUVER

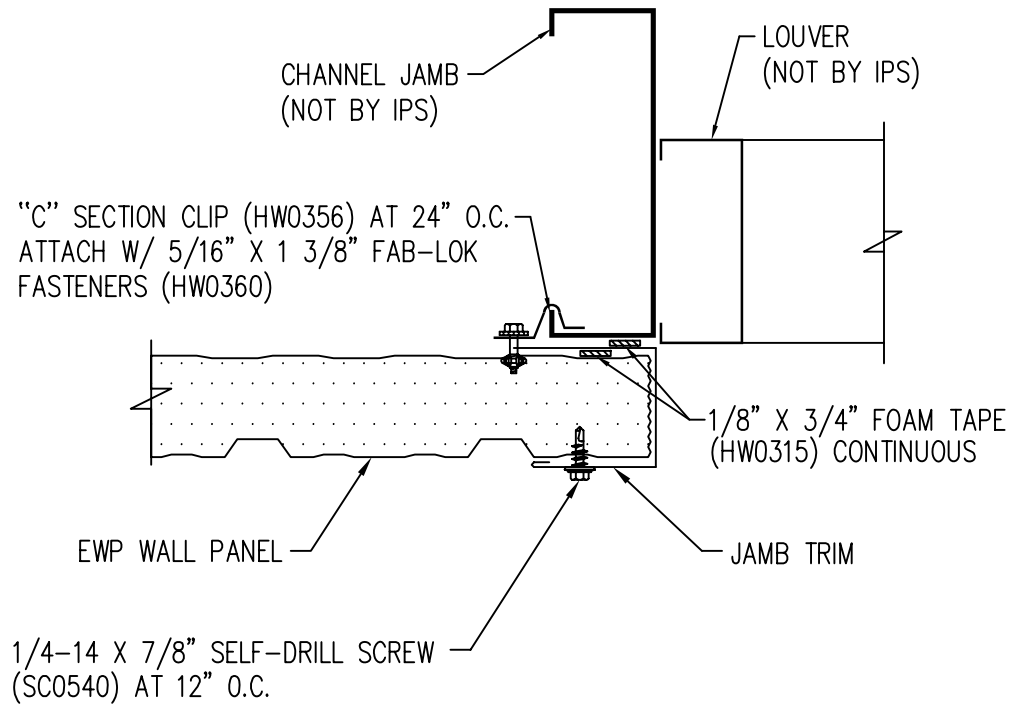

JAMB DETAIL AT LOUVER

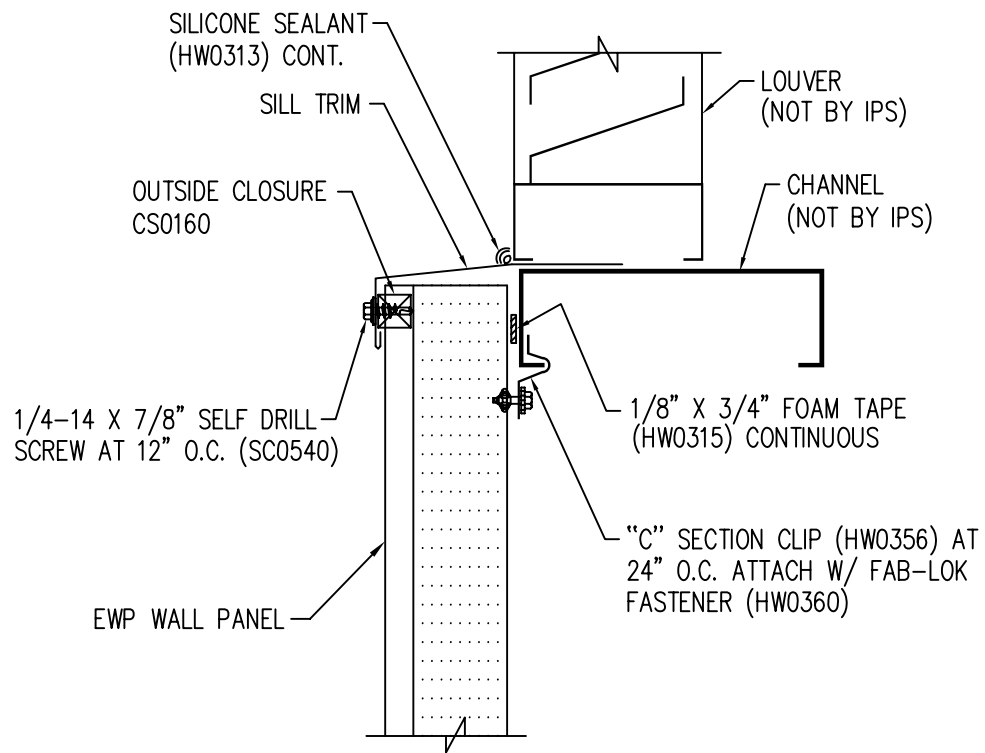

SILL DETAIL AT LOUVER

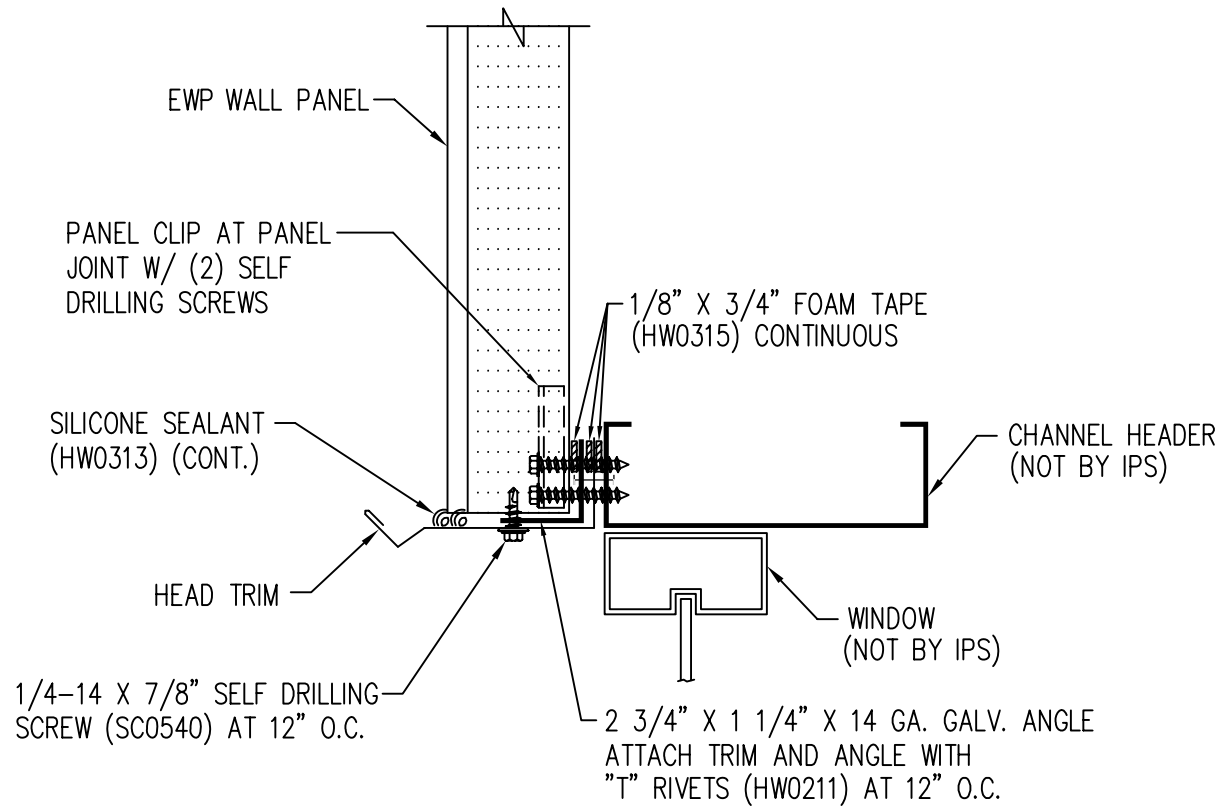

HEAD DETAIL AT WINDOW

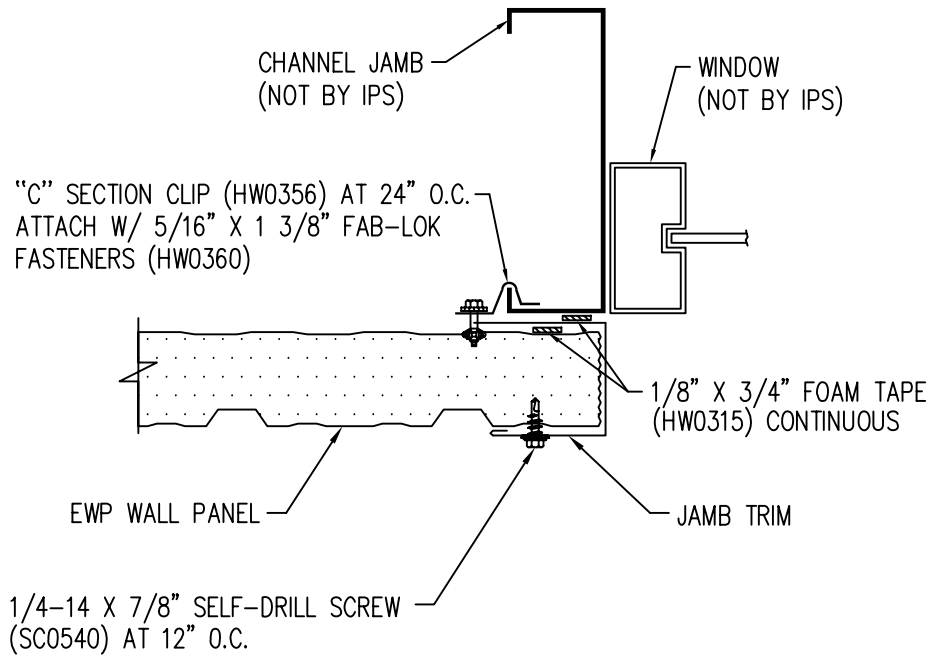

JAMB DETAIL AT WINDOW

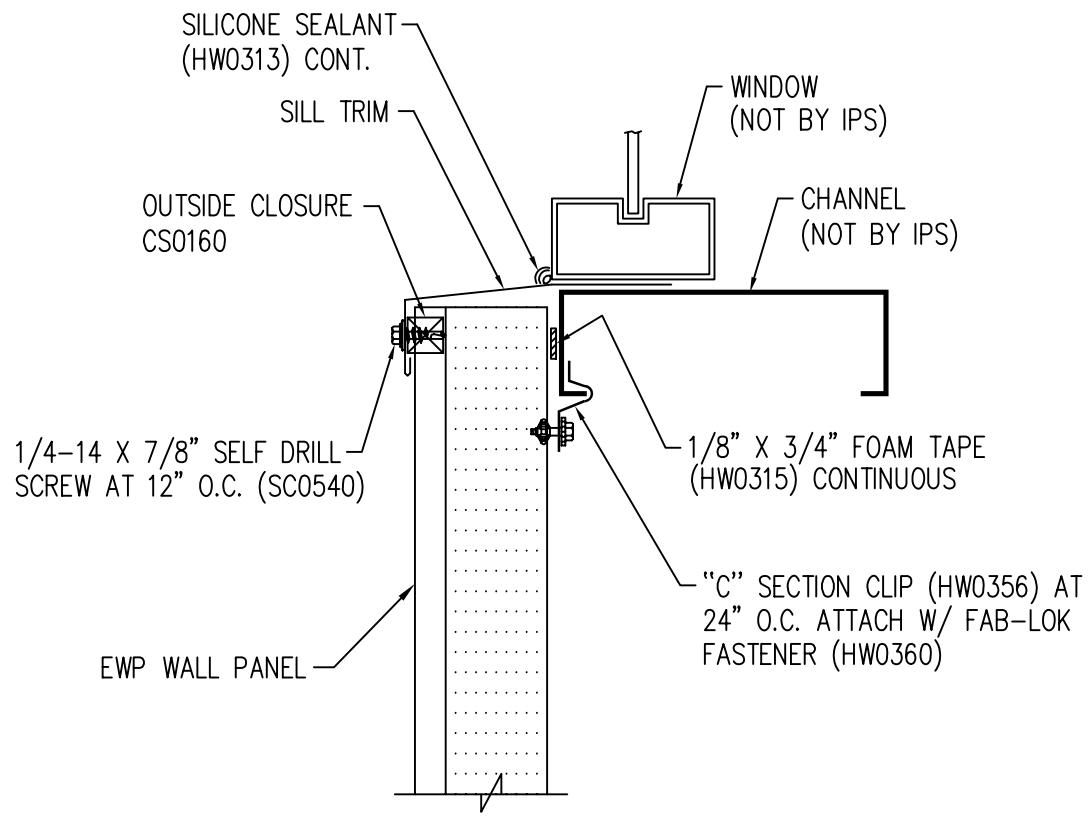

SILL DETAIL AT WINDOW

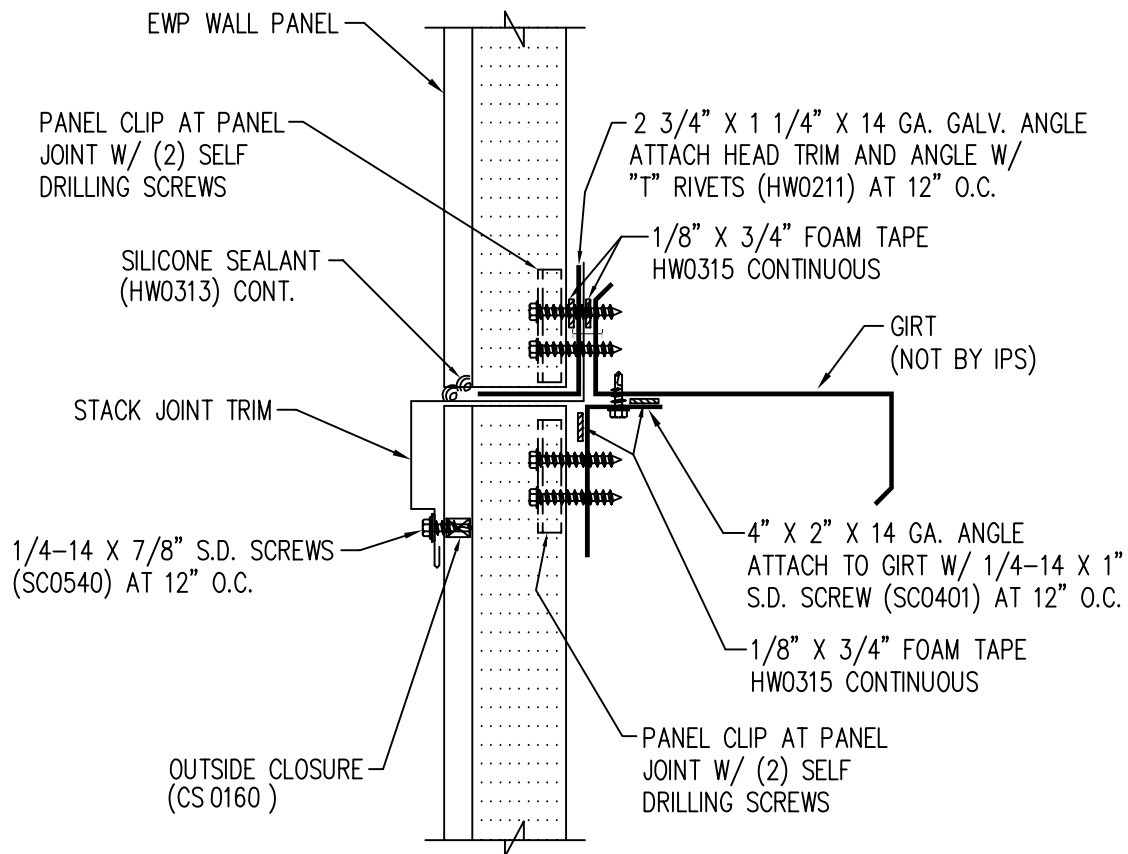

DETAIL AT WALL SPLICE WITH COLD FORMED MEMBER

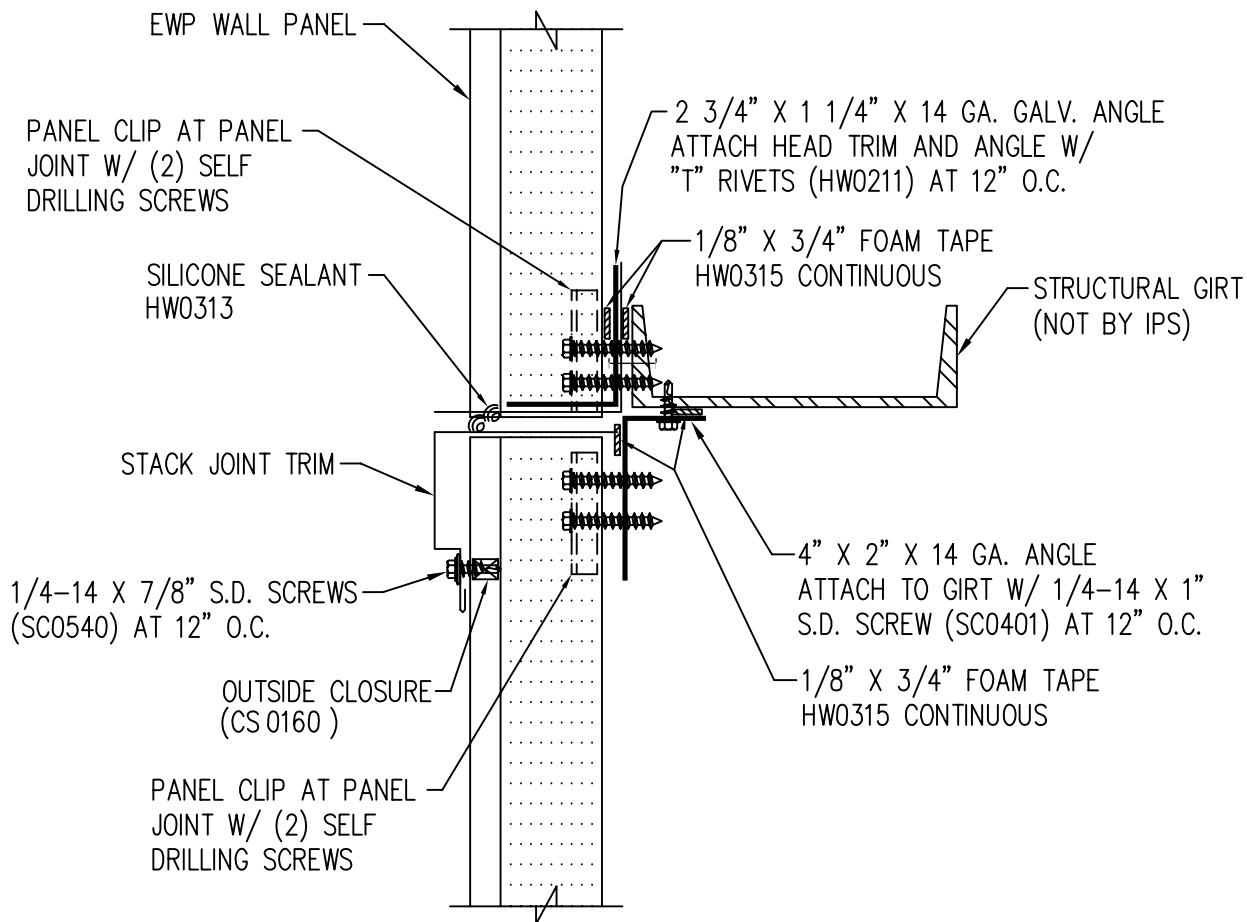

DETAIL AT WALL SPLICE WITH HOT ROLLED MEMBER

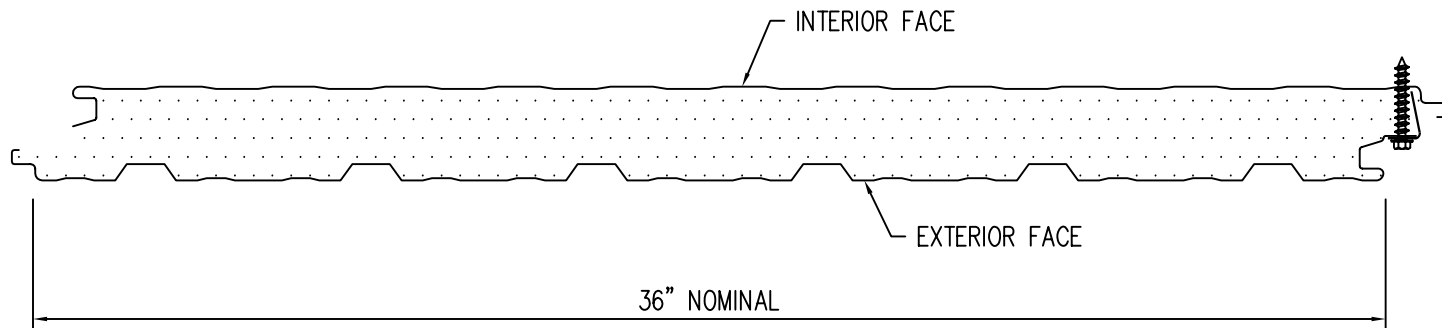

EWP WALL PANEL
FASTENER PLACEMENT DETAIL

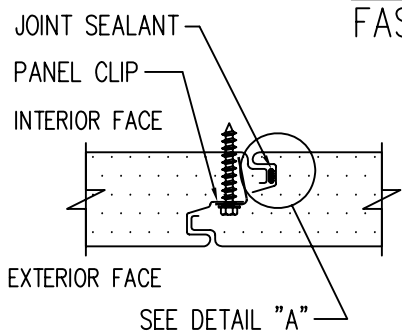

JOINT SEALANT APPLICATION

NOTE: —————
FIELD APPLIED JOINT SEALANT
HW0301, APPLY MINIMUM 3/8"
BEAD. ONE TUBE = APPROX.
15 L.F. OF PANEL JOINT

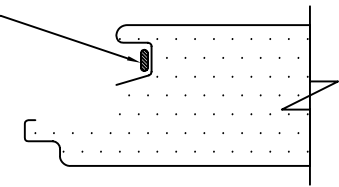

DETAIL "A"