

This drawing refers to liner conditions only. Refer to additional details for exterior sheeting and trim conditions.

PBU Liner At Corner  
By-Pass Girts

SHT. NO. UL01002	
DATE Jan. 09	REV. 00

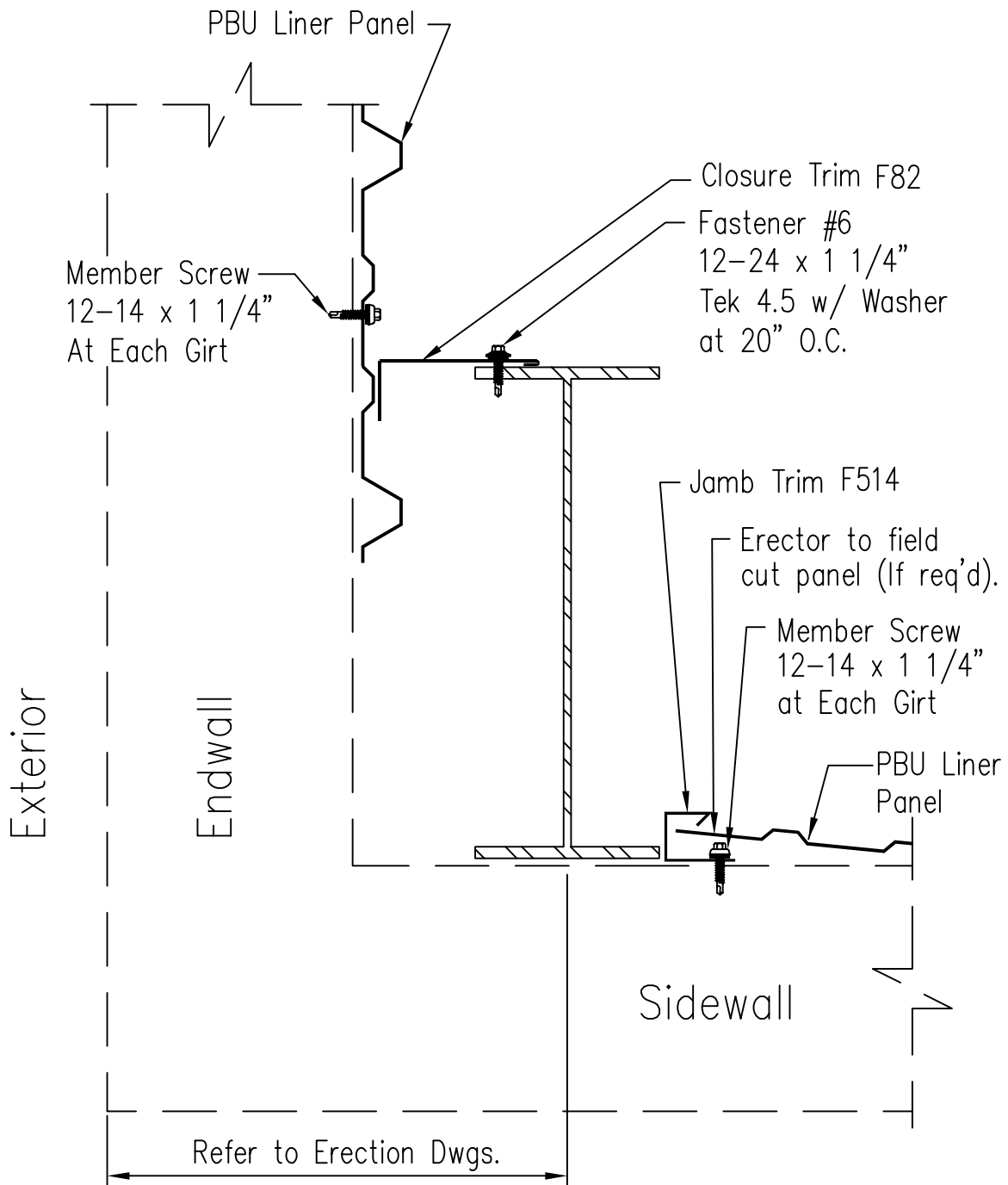

This drawing refers to liner conditions only. Refer to additional details for exterior sheeting and trim conditions.

PBU Liner At Flush Corner Corner  
Column Depth Exceeding Girt Depth

SHT. NO. UL01003	
DATE Oct. 09	REV. 01

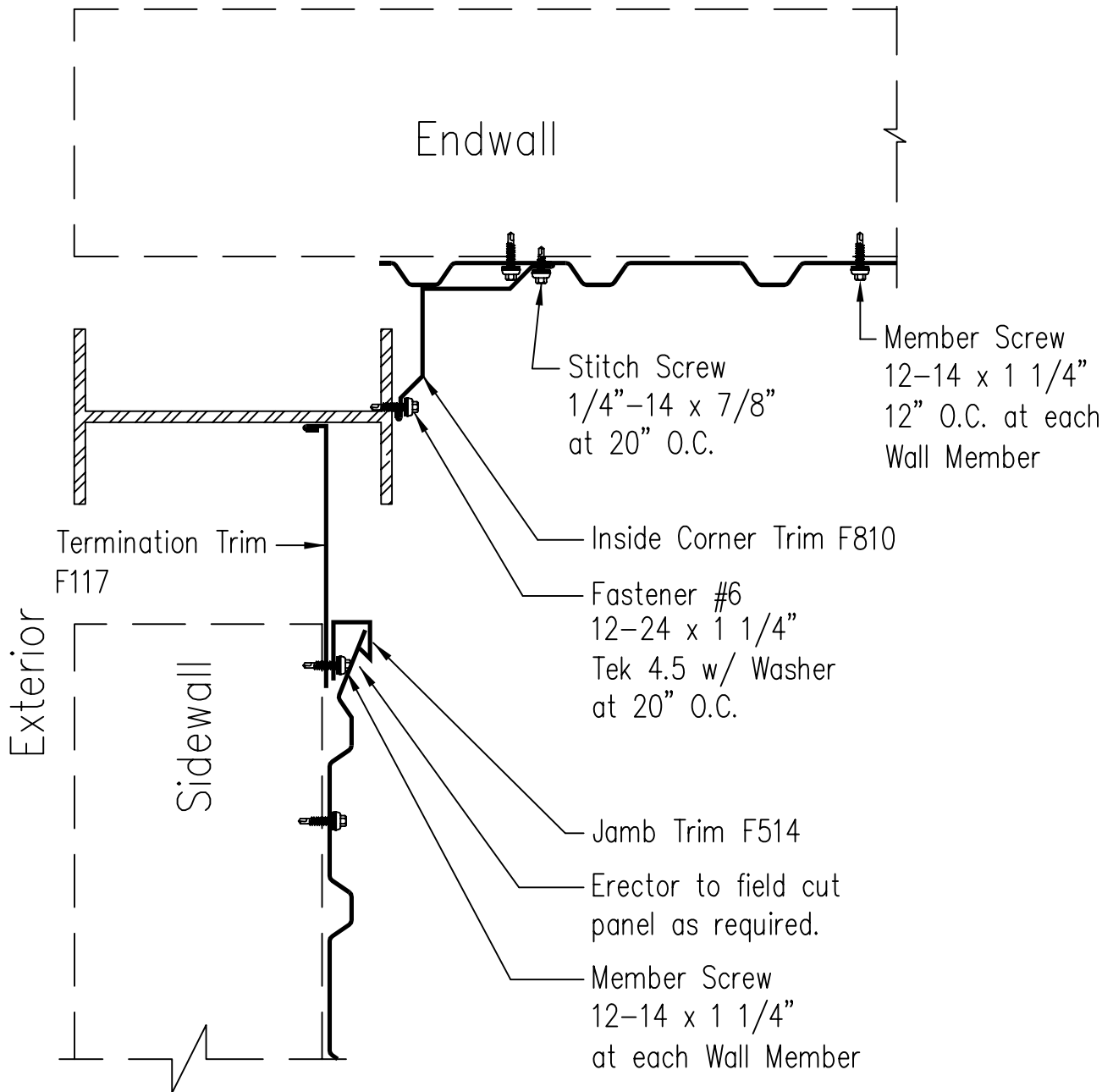

This drawing refers to liner conditions only. Refer to additional details for exterior sheeting and trim conditions.

PBU Wall Liner  
Flush Interior Colum

SHT. NO. ULO1004	
DATE Oct. 09	REV. 01

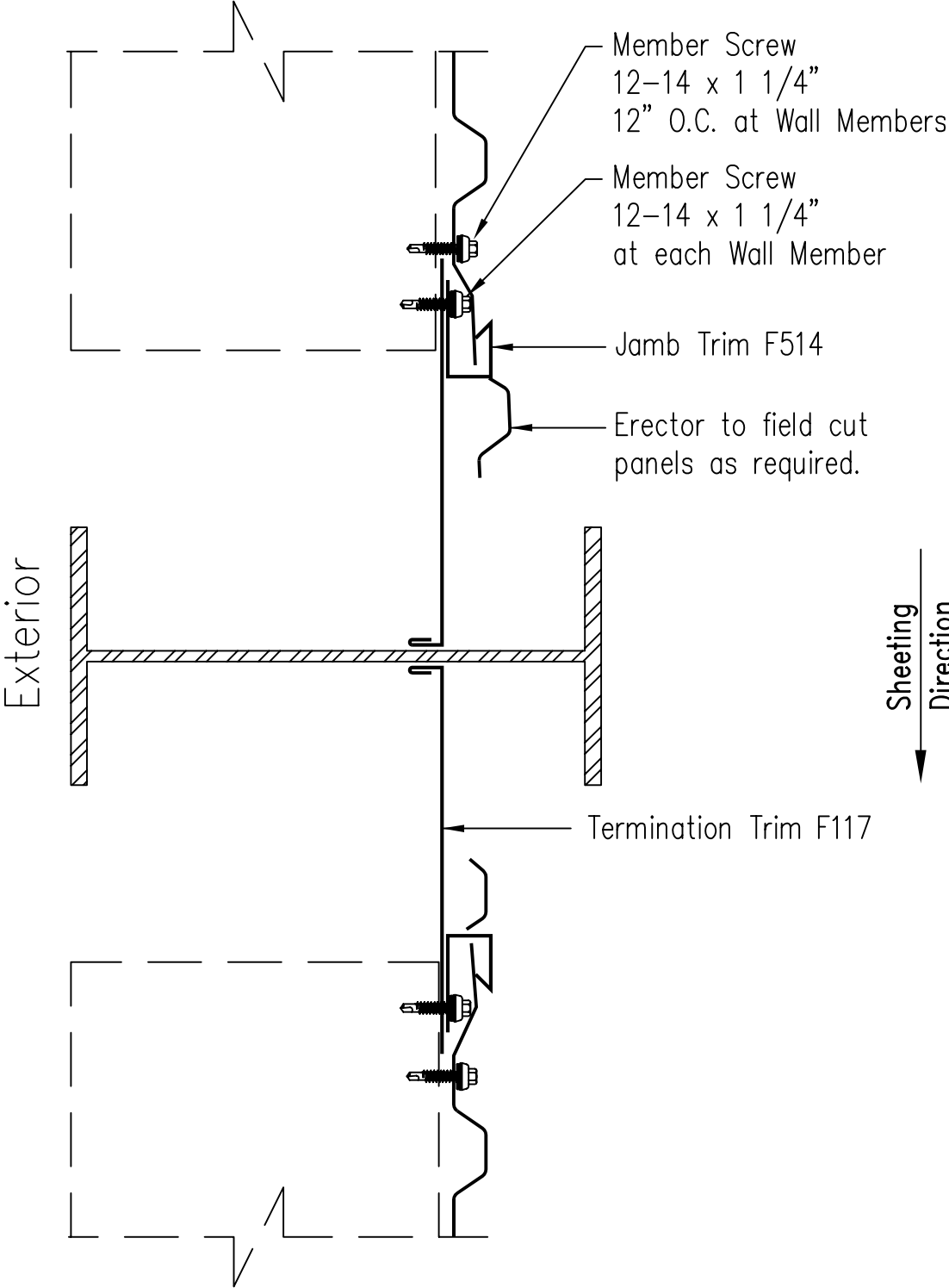

This drawing refers to liner conditions only. Refer to additional details for exterior sheeting and trim conditions.

PBU Wall Liner  
Interior Coumn By-Pass Girts

SHT. NO.  
UL01005

DATE  
Jan. 09

REV.  
00

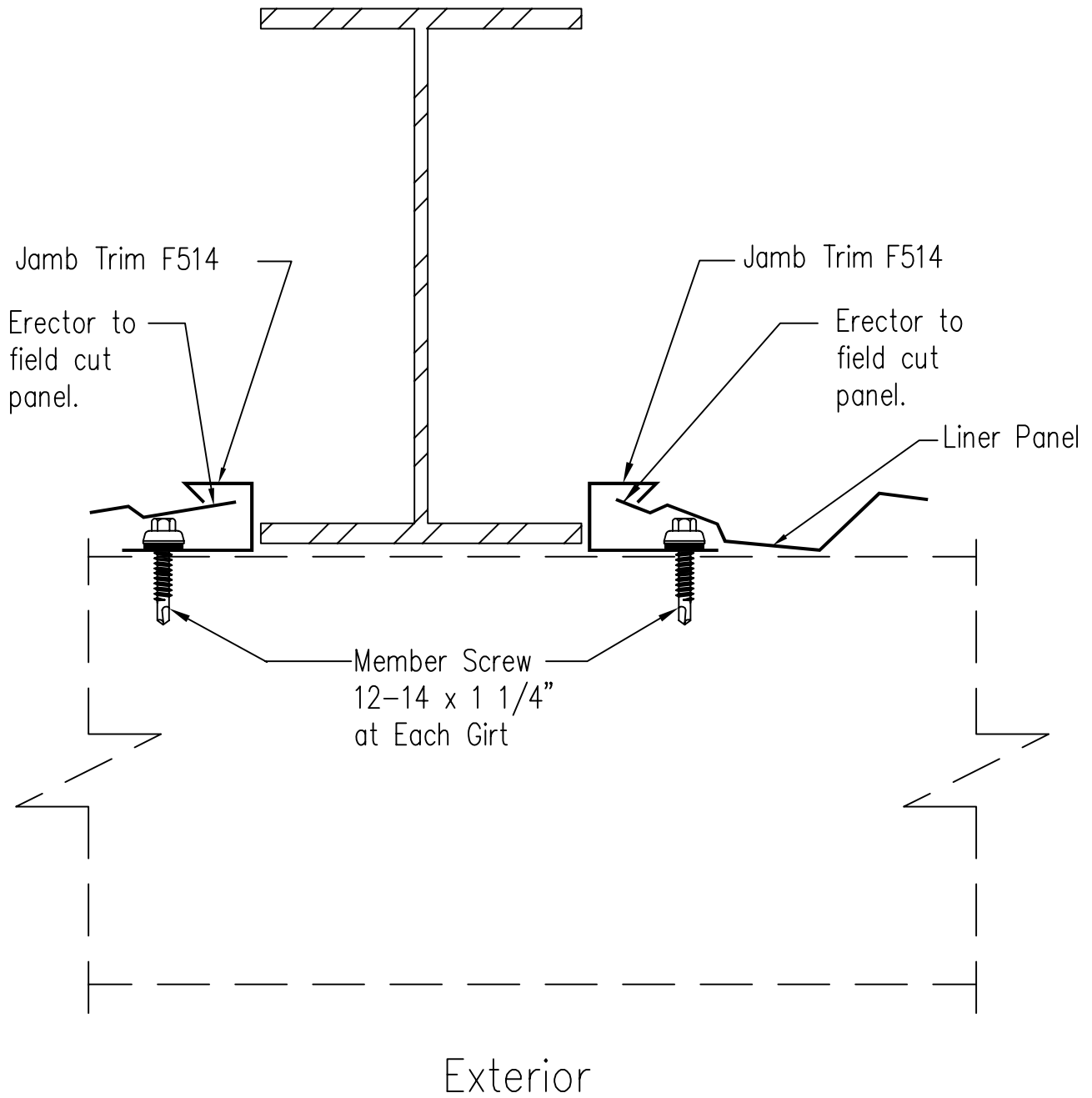

This drawing refers to liner conditions only. Refer to additional details for exterior sheeting and trim conditions.

PBU Wall Liner  
Full Height

SHT. NO. UL01006	
DATE Oct. 09	REV. 01

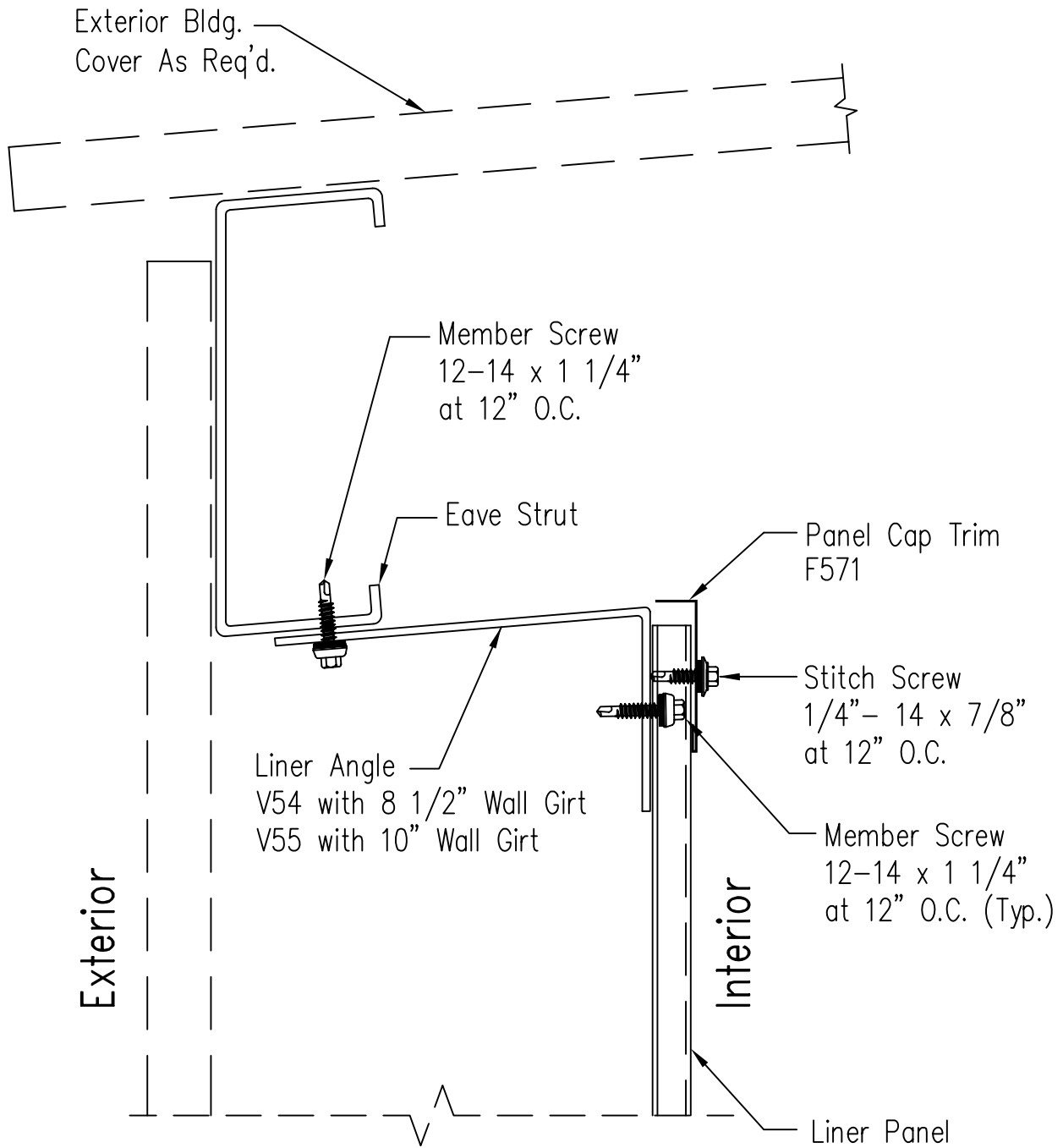

Section At Eave

This drawing refers to liner conditions only. Refer to additional details for exterior sheeting and trim conditions.

PBU Wall Liner  
with PBU Roof Liner

SHT. NO. UL01007	
DATE Oct. 09	REV. 01

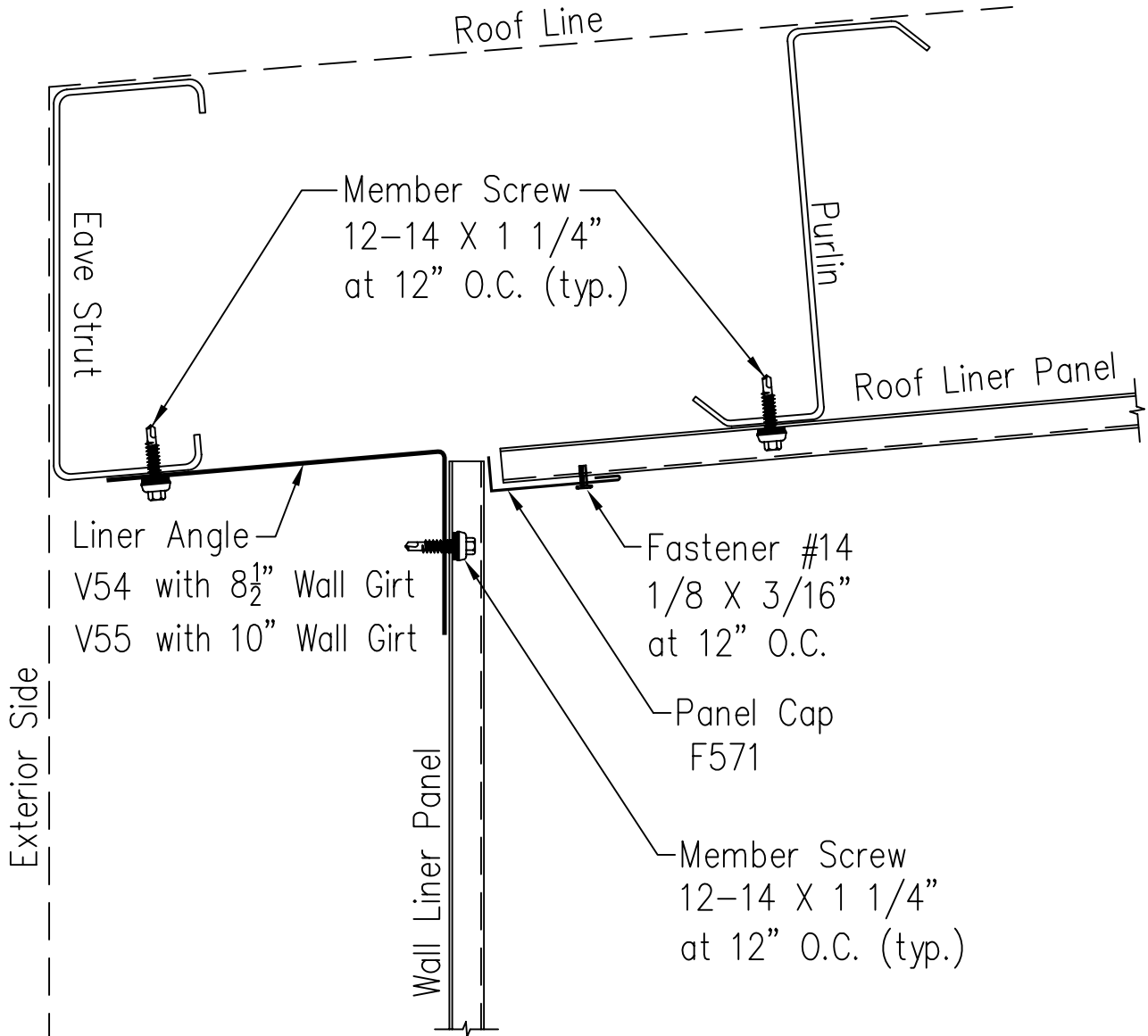

Note: This drawing refers to liner conditions only. Refer to additional details for exterior trim conditions.

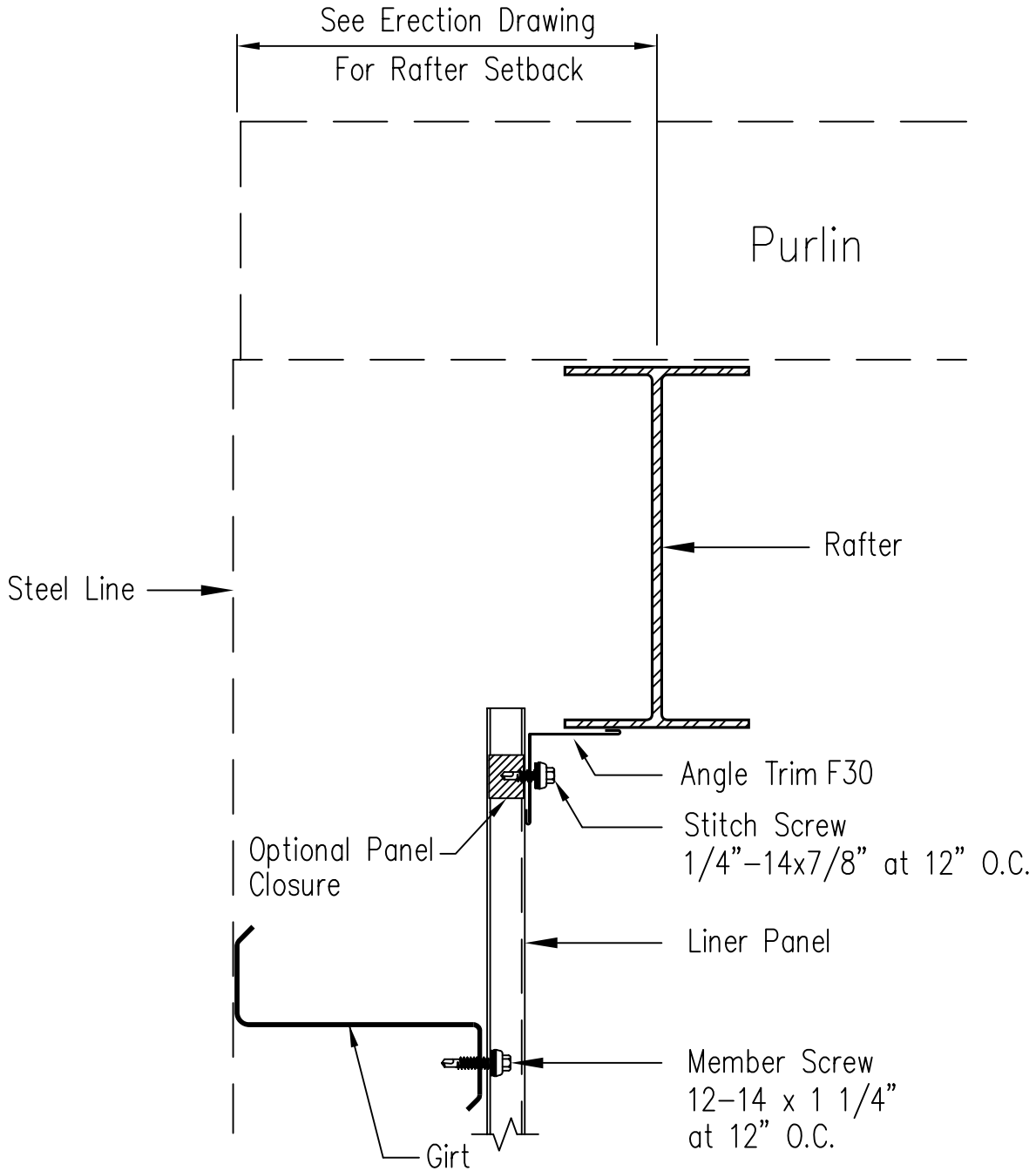

This drawing refers to liner conditions only. Refer to additional details for exterior sheeting and trim conditions.