

Commercial/Industrial Installation Guide

CF SERIES - VERTICAL

CONTENTS

1. Introduction.....	3
2. CF Panel Profiles.....	6
3. Framing Alignment.....	9
4. Receiving.....	10
5. Material Handling.....	13
6. Storage and Staging.....	20
7. Panel Cutting.....	21
8. Panel Sealant.....	24
9. Panel Fasteners.....	25
10. Cleaning.....	26
11. Touch-up.....	26
12. Interior Trim Installation.....	27
13. Panel Installation.....	34
14. Exterior Trim Installation.....	46
15. General Details <i>(for reference only)</i>	51
16. Penetrations.....	75
17. Extrusions.....	79
18. Tools, Hardware and Supplies.....	83

Disclaimer

This guide is intended to be used in conjunction with the project's installation drawings. The installation drawings should identify the applicable wall conditions, specify the components and the required arrangement of the components. Specific building design and construction conditions may require variations from the information in this guide.

Metl-Span does not guarantee and is not liable for the quality of installation. Metl-Span is not responsible for defects that may be attributed to improper installation, the negligence of other parties, or for materials not provided by Metl-Span.

All safety procedures including but not limited to fall protection and material handling are the exclusive responsibility of the installing contractor.

Unless specified in writing, Metl-Span makes no expressed or implied warranties pertaining to the fitness of the wall panels or its components for any particular purpose, and shall not be responsible for any indirect or consequential damages, such as to building contents, nor for any further loss of any kind to the owner or contractor.

Metl-Span does not warrant any product or material as meeting the ordinances, laws or regulations of any particular state or local municipality, and Metl-Span is not responsible for conformance by the owner or contractor to such ordinances, laws or regulations.

1. INTRODUCTION

Welcome to Metl-Span, the dynamic industry innovator dedicated to manufacturing and marketing the highest quality insulated building panel products. Since our origination in 1968, we have been pioneers in research, design, production and sales of state-of-the-art insulated metal panels and building materials serving the commercial, industrial, institutional and cold storage industries.

Our mission is clearly defined: Deliver the highest quality energy-efficient solutions to insulate and protect our world.

This installation guide is designed to provide step by step instructions for vertical commercial/industrial CF series wall panels.

For more information regarding proper panel installation, please contact Metl-Span Technical Services:

1720 Lakepointe Drive, Suite #101
Lewisville, Texas 75057
TEL: (972) 221-6656
Fax: (972) 436-7028
E-mail: info@metlspan.com
Website: www.metlspan.com

1. INTRODUCTION

Safety

In the USA, the Occupational Safety and Health Act (OSHA) governs regulations with the objective of protecting workers from injury or accident. “Part 1926, Safety and Health Regulations for Construction” are applicable to the wall installation.

In Canada, Occupational Safety and Health (OSH) regulation is under the jurisdiction of the local provinces and territories. Federal employees and Crown agencies may be subject to federal OSH jurisdiction.

The OSHA and OSH regulations should be recognized as job site requirements and fully complied with. Safe installation practices may be further defined and made mandatory by state or local ordinances.

All safety procedures are the responsibility of the panel installation contractor. If the installer determines that they cannot safely install the panels in accordance with the installation drawings or this guide, it is their responsibility to determine appropriate alternative procedures.

Owner’s Responsibilities

“Owner” as used throughout this guide refers to the project’s owner and/or his representatives, such as the project’s architect, design engineer and general contractor. These parties are responsible for determining the following:

- Selection of a competent installer who is qualified and experienced in the proper installation of insulated metal panels and related construction.
- Installer has reviewed and understands the project’s installation drawings and this guide *prior* to installation.
- Panels and related components are installed in accordance with the project’s installation drawings and the applicable portions of this guide.
- Panels are suitable for the purpose intended.
- Project’s structural framing is properly designed and in satisfactory condition to accept the erection and design loads imposed by the wall panels.
- Location of interior and/or exterior panel joint and perimeter seals are properly specified for the project’s moisture and vapor control requirements.
- Panels and related components are installed in compliance with the applicable codes, regulations, service conditions and good engineering and construction practices.

1. INTRODUCTION

Installation Drawings

Installation drawings (also known as shop drawings) are usually prepared by the installation contractor, Metl-Span or some other party depending on preferences or contractual requirements.

Installation drawings must be “approved” by the project architect before they are to be used for construction. *It is critical that the “approved installation drawings” are in agreement with the final architectural and structural drawings as well as all addenda.*

Approved installation drawings (labelled “for construction” or “for production”) must be available at the job site during the preparation, installation and inspection of the wall support framing, wall panels, flashings and other related construction.

The installation drawings must be reviewed for differences with field conditions, and discrepancies should be resolved before proceeding with panel installation.

In case of conflict between this guide and “for construction/for production” installation drawings, the drawings govern.

2. CF PANEL PROFILES

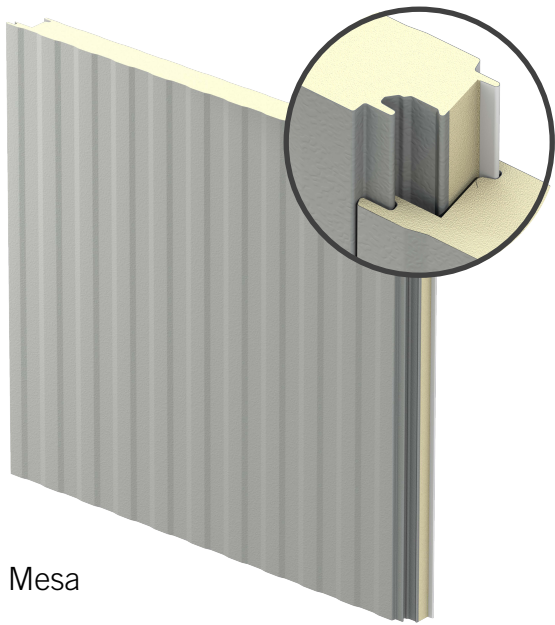

Mesa

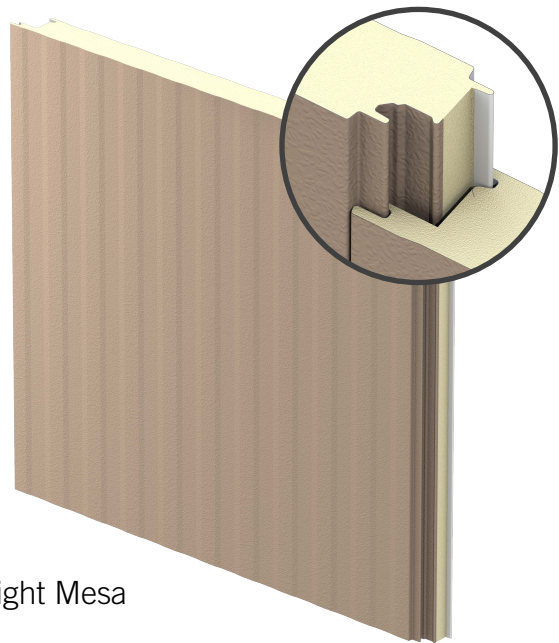

Light Mesa

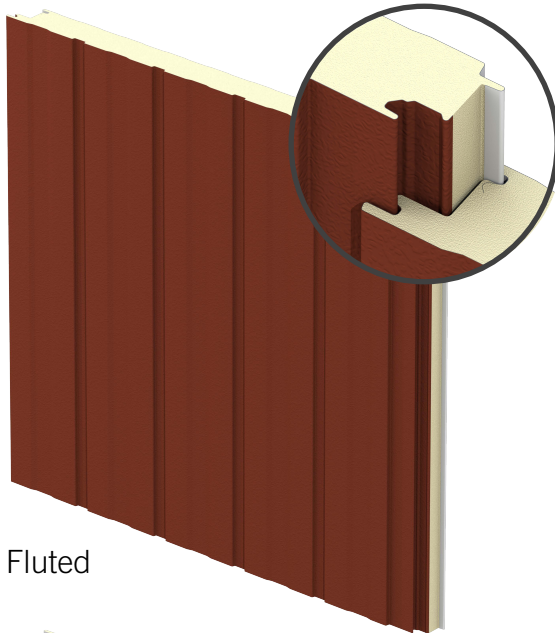

Fluted

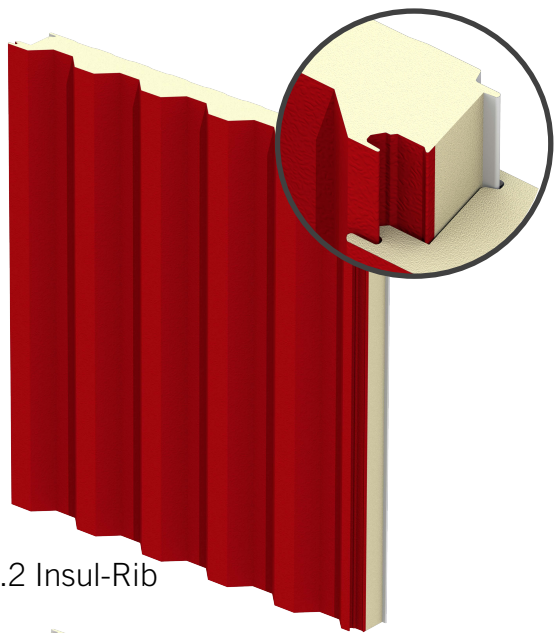

7.2 Insul-Rib

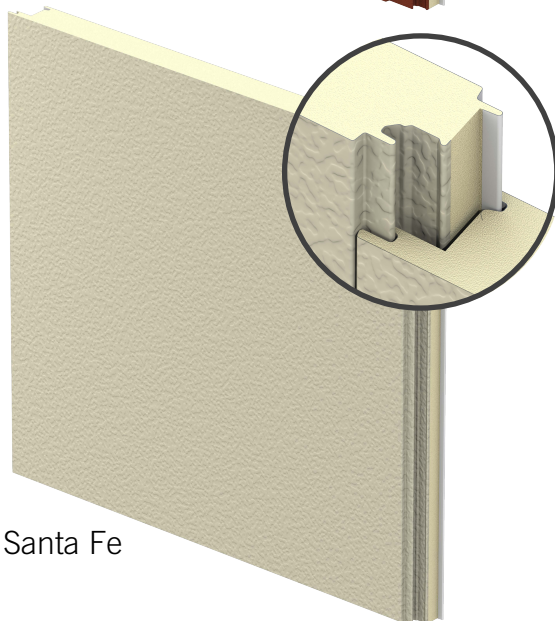

Santa Fe

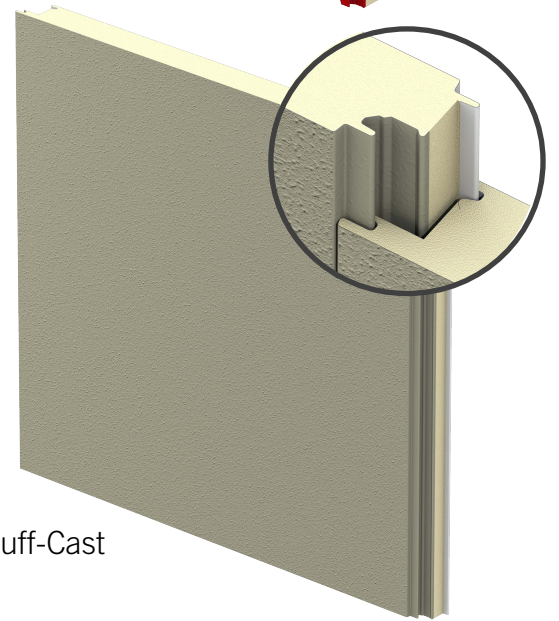

Tuff-Cast

2. CF PANEL PROFILES

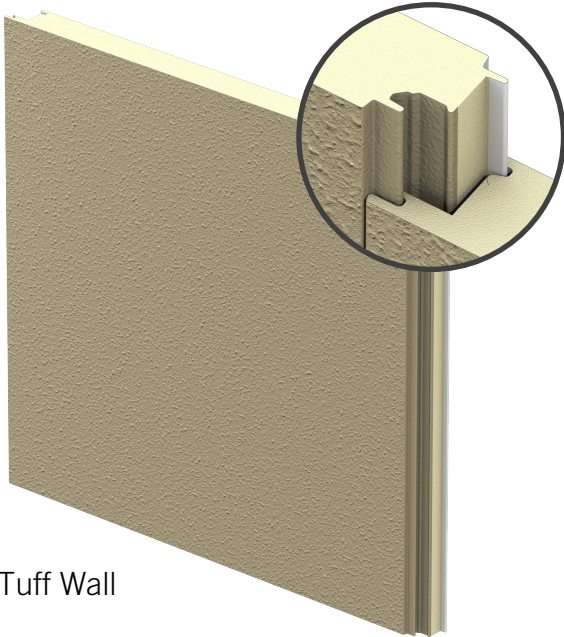

Tuff Wall

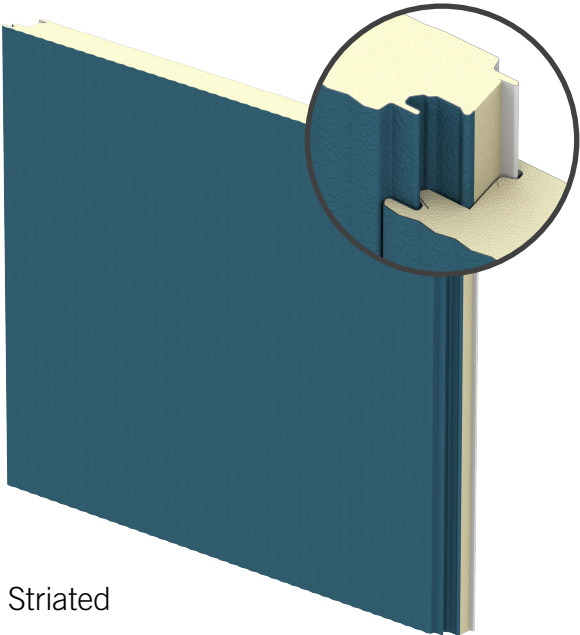

Striated

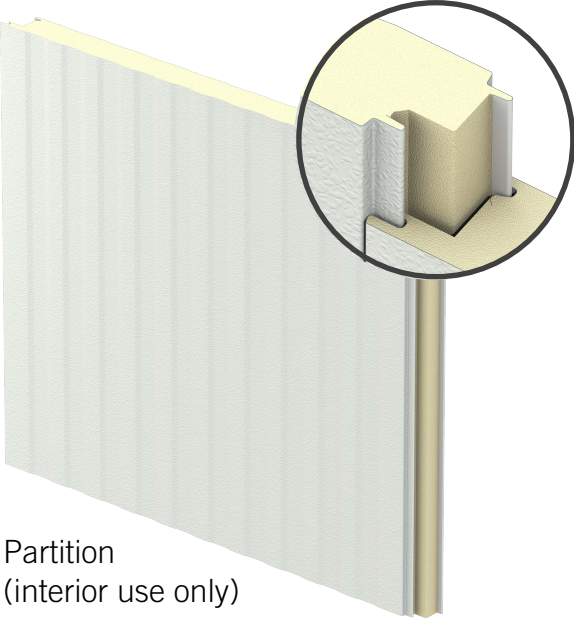

Partition
(interior use only)

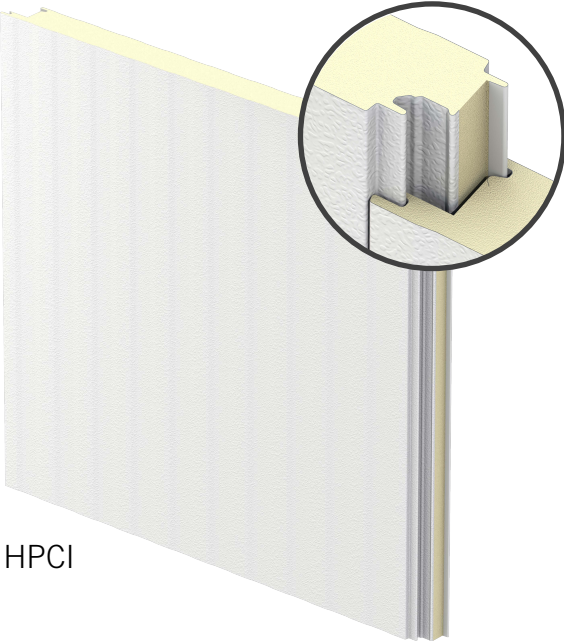

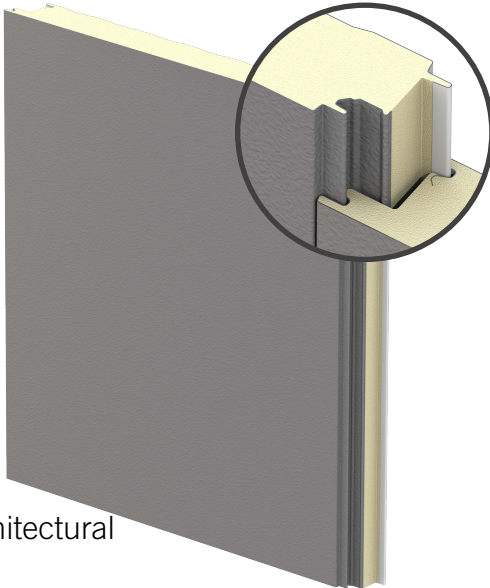

HPCI

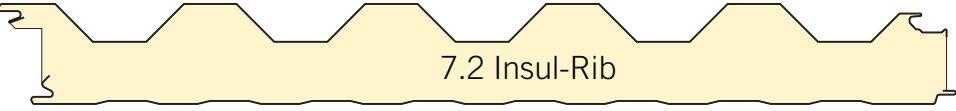

Architectural

2. CF PANEL PROFILES

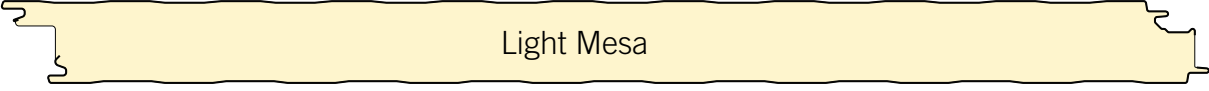
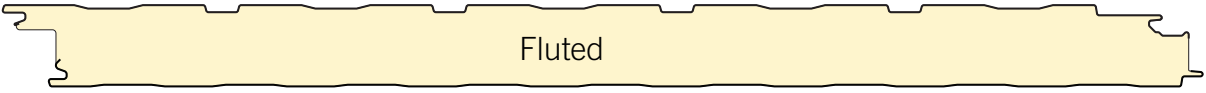
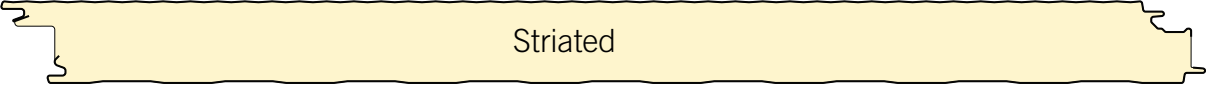
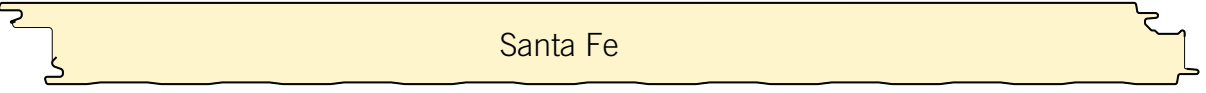
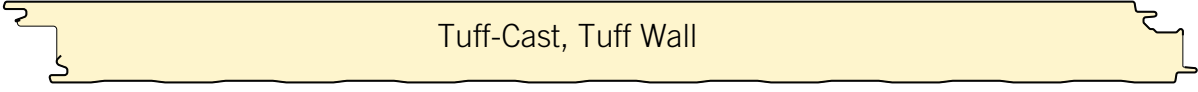
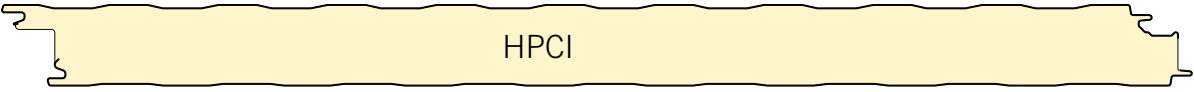
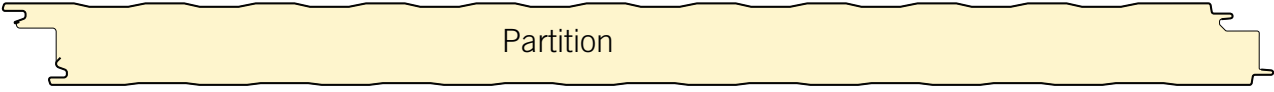
	Architectural	2"- 4"
	24", 30", 36"	
	7.2 Insul-Rib	2.5"- 6"
	36"	
	Mesa	2"- 6"
	30", 36", 42"	
	Light Mesa	2"- 6"*
	30", 36", 42"	*5" and 6" interior use only
	Fluted	2"- 6"
	42"	
	Striated	2"- 4"
	24", 30", 36", 42"	
	Santa Fe	2"- 4"
	24", 30", 36", 42"	
	Tuff-Cast, Tuff Wall	2"- 6"**
	36", 42"	**5" and 6" require Mesa profile on both faces
	HPCI	2"- 6"
	42"	
	Partition	2"- 6"
	44.5"	

3. FRAMING ALIGNMENT

3.1 Framing alignment should be checked *before* panels are delivered to site.

3.2 Compare structural and panel shop drawings to ensure wall supports are in correct location. Field measure support spacing and overall building dimensions.

WARNING: RESOLVE ALL DIMENSIONAL DIFFERENCES WITH SHOP DRAWINGS BEFORE PANEL INSTALLATION BEGINS!

3.3 If base support is installed, verify it is aligned with slab edge/notch.

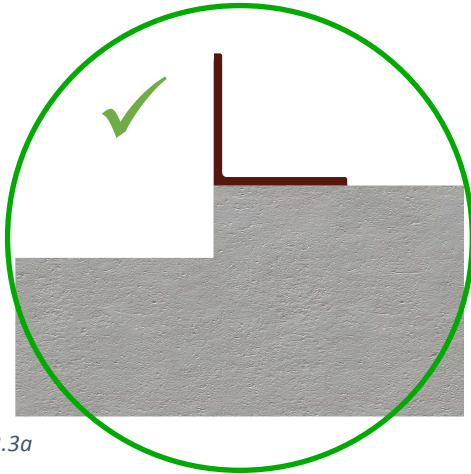

Figure 3.3a

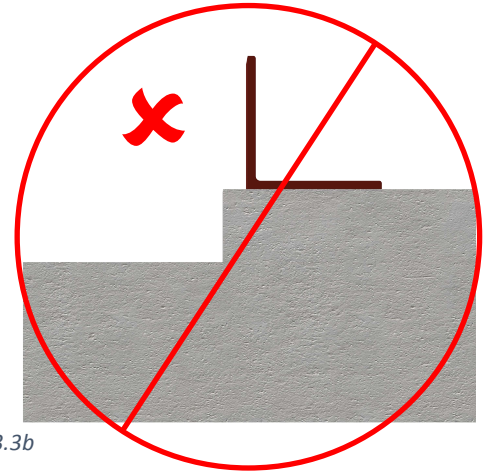

Figure 3.3b

3.4. Check alignment at mid-span and column lines with a laser or plumb bob from the top wall support to the base support or slab edge.

3.5 Check support alignment against these tolerances for *vertical panel installation*:

< 8' spacing: +1/8", -0"

≥ 8' spacing: +1/4", -0"

(Architectural flat panels: < 4' spacing: +1/16", -0")

3.6 All supports not in alignment must be corrected by the responsible party *before* panel installation begins.

WARNING: IMPROPER FRAMING ALIGNMENT CAN CAUSE DIFFICULTY WITH PANEL ENGAGEMENT AND RIPPLING OR BUCKLING OF THE PANEL FACES.

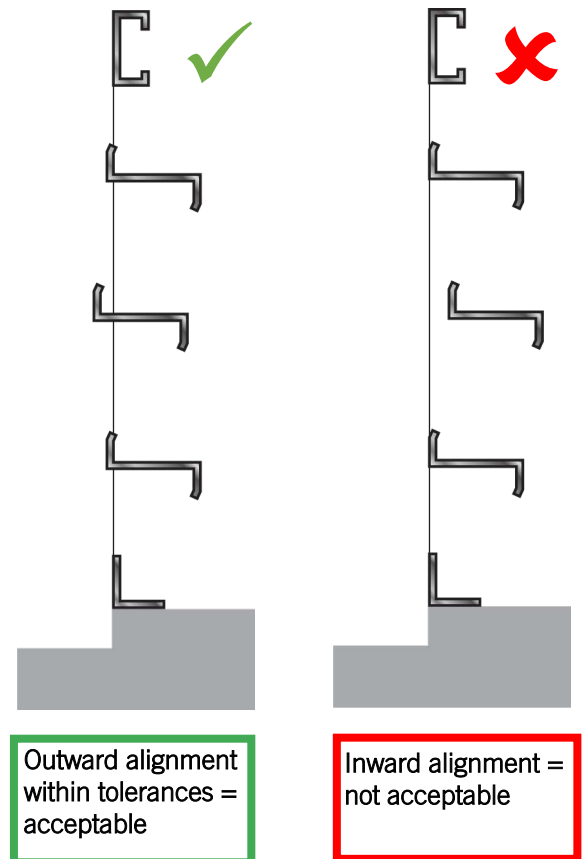



Figure 3.4

4. RECEIVING

4.1 Proper offloading equipment must be on site *prior to arrival of panels and accessories*. All bundles and crates are packaged for side unloading by forklift or by crane. Maximum bundle weight is 5,000 lbs.

4.2 Check all materials immediately upon arrival for freight damage. Inspect for strap damage, forklift damage or packaging/bundle wrap damage.

4.3 Verify that the order number, quantities and descriptions of all bundles, crates and pallets on the bill of lading match those on the truck.



STRAIGHT BILL OF LADING

DUPLICATE (COPY OF ORIGINAL).

BOL #	123456
Job #	54321

Ship Date: July 17, 2015

Delivery Date: July 17, 2015 08:00 am

Consignee: IMP EXPERTS
 HQ BUILDING
 123 PEMB AVENUE
 ANYTOWN, US 00123

Shipper: METL-SPAN
 4700 Engineers Way
 North Las Vegas, NV 89081

Contractor:

PO Number: 12345678

Panels			Accessories		
Bundle	Qty in Bundle	Weight	Number	Type	Weight
6-1	11	1275	NV-1	8' Box	750
6-2	11	1247	NV-2	20' Box	600
6-3	8	824	NV-3	Skid	300
6-4	7	721	NV-4	10' Box	1100
6-5	8	936	NV-5	20' Box	400
6-6	8	936			
6-7	6	702			
6-8	6	615			
6-9	1	88			
Total Weight: 10494					

NOTE - Where the rate is dependent on value, shippers are required to state specifically in writing the agreed or declared value of the property. The agreed or declared value of the property is hereby stated by the shipper to be not exceeding \$_____ Per _____. Subject to Section 7 of the conditions, if the shipment is to be delivered to the consignee without recourse on the consignor, the consignor shall sign the following statement. RECEIVED: subject to the classifications and lawfully filed tariffs in effect on the date of issue of this Bill of Lading, the property described above is in apparent good order, except as noted (contents and condition of contents of packages unknown), marked, consigned, and destined as indicated above which said carrier (the word carrier being understood throughout this contract as meaning any person or corporation in possession of the property under the contract) agrees to carry its usual place of delivery at said destination, if on its route, otherwise to deliver to another carrier on the route to said destination. It is mutually agreed as to each carrier of all or any of, said property over all or any portion of said route to destination and as to each party at any time interested in all or any said property, that every service to be performed hereunder shall be subject to all the bill of lading terms and conditions in the governing classification and the said terms and conditions are hereby agreed to by the shipper and accepted for himself and his assigns. Where applicable tariff provisions specify a limitation of the carrier's liability (NMFC Item 172), if there is no release of value declaration by the shipper, and the shipper does not declare a value or release the carriers' liability, that liability shall be limited to the extent provided by NMFC Item 172. California intrastate shipments must comply with NMFC Item 173. This is to certify that the above - named materials are properly classified, describe, packages, marked, labeled, and are in proper condition for transportation according to the applicable regulations of the Department of Transportation.

<p style="font-size: x-small; margin: 0;">IN CASE OF ANY DELAYS PLEASE CONTACT I.M. Panel at (987) 654-3210. FAILURE TO REPORT ANY DELAYS MAY SUBJECT CARRIER TO BACK CHARGE.</p> <p>Shipper: METL-SPAN</p> <p>Per: _____</p> <p>Date: _____</p>	<p style="text-align: center; font-weight: bold; font-size: small;">RETURN THIS COPY WITH INVOICE</p> <p>Carrier: IMPHAULER</p> <p>Truck #: 4321</p> <p>Driver: _____</p> <p>Date: _____</p>	<p>Site Contact: BILL DOZER (123) 456-7890</p> <p>Received By: _____</p> <p>Date: _____</p>
--	--	--

Figure 4.3

4.4 List all *visible* damages and/or shortages on the bill of lading, obtain the signature of the truck driver and an authorized representative of the Metl-Span customer.

4.5 Keep a copy of the marked-up bill of lading and send it with digital photos of the damage to Metl-Span Customer Relations.

4.6 Concealed damages/shortages must be reported to Metl-Span within 15 days of delivery.

4. RECEIVING

4.7 The panel bundling and accessories report lists the specific contents of each bundle, crate and pallet listed on the bill of lading.



Customer: IMP EXPERTS
Project: HQ BUILDING

Job# 54321

BOL# 123456

PO# 12345678

Panel Bundling Report

Bundle #	Qty	Item #	Weight	Item Desc.	Thickness	Length	Panel Type
6-1	2	2	244	CFS1-1	4	11'-10"	CF42F
	2	4	226	CFS1-2	4	10'-11"	CF42F
	3	5	393	CFS1-3	4	12'-8"	CF42F
	4	9	412	CFS3-1	4	10'-0"	CF42F
6-2	2	6	226	CFS2-1	4	10'-11"	CF42F
	2	7	244	CFS2-2	4	11'-10"	CF42F
	2	8	262	CFS2-3	4	12'-8"	CF42F
	5	9	515	CFS3-1	4	10'-0"	CF42F
6-3	3	9	309	CFS3-1	4	10'-0"	CF42F
	5	11	515	CFS4-1	4	10'-0"	CF42F
6-4	7	11	721	CFS4-1	4	10'-0"	CF42F
6-5	8	1	936	CFR-1	5	10'-7 3/4"	CF42R
6-6	8	1	936	CFR-1	5	10'-7 3/4"	CF42R
6-7	6	1	702	CFR-1	5	10'-7 3/4"	CF42R
6-8	3	1	351	CFR-1	5	10'-7 3/4"	CF42R
	3	3	264	CFR-2	5	8'-0"	CF42R
6-9	1	3	88	CFR-2	5	8'-0"	CF42R

Accessories

Item #	Part #	(Alt #)	Weight	Qty	Description	Pkg Type	Pkg #
23	F294		1100	6	Low Eave Trim	10' Box	NV-4
24	F3243		1100	6	4" Head Trim	10' Box	NV-4
25	F3243		1100	1	4" Head Trim	10' Box	NV-4
26	F3243		1100	1	4" Head Trim	10' Box	NV-4
27	F3243		1100	1	4" Head Trim	10' Box	NV-4
30	F3432		1100	1	Rake Trim	10' Box	NV-4
32	F3434		1100	2	Rake Trim	10' Box	NV-4
33	F3434		1100	2	Rake Trim	10' Box	NV-4
34	F3444		1100	6	Rake Zee	10' Box	NV-4
36	F3510		1100	10	Rake Angle Lap Cover	10' Box	NV-4
38	F3700L		1100	4	Rake Closure/Left	10' Box	NV-4
39	F3700R		1100	4	Rake Closure/Right	10' Box	NV-4

Figure 4.7

4. RECEIVING

4.8 Every bundle and trim/accessory crate has a shipping label that contains information on the contents.

JOB NUMBER				PACKAGE NUMBER			
54321				6-1			
CUSTOMER NAME: IMP EXPERTS				PANEL: 4CF42F/LM			
JOB NOTES:				FACE 1:		Brownstone 433R600 Kynar 500 Non-directional Embossing 24 Gauge	
SPECIAL REQUIREMENTS: LEED (BAA) Compliant							
P.O. Number: 12345678				FACE 2:		Snow White (K5) 431R539 Kynar 500 Non-directional Embossing 26 Gauge	
CAULKING REQUIREMENT: EXTERIOR:		INTERIOR:					
ITEM NUMBER	ITEM DESC.		PANEL LENGTH		QUANTITY	EXTRA	
2	CFS1-1		11'- 10"		2	0	
4	CFS1-2		10'- 11"		2	0	
5	CFS1-3		12'- 8"		3	0	
9	CFS3-1		10'- 0"		4	0	
OPERATOR:		SHIFT:		PROD DATE: 07/13/15	TIME: 10:15 am	TOTAL PACKAGED: 11	

Figure 4.8

5. MATERIAL HANDLING - Bundles

Forklifts

- 5.1 Identify and mark off unloading area prior to material delivery.
- 5.2 Verify adequate material handling equipment with the proper reach and capacity is on site. Bundle weights are listed on the bill of lading, and have a maximum weight of 5,000 lbs.
- 5.3 Pre-determine the panel storage area prior to material delivery. It must be secure, flat, well-drained and reasonably level.
- 5.4 Panels are shipped via flatbed trailer, and can be off-loaded from the side of the trailer using forklifts.
- 5.5 Guidelines for off-loading are as follows:

Panel thickness	Bundle length	
2-2.75" thick	<36' = 1 forklift	≥36' = 2 forklifts
3" thick	<40' = 1 forklift	≥40' = 2 forklifts
4-6" thick	<48' = 1 forklift	≥48' = 2 forklifts

5.6 Tape foam blocks on forks to prevent over-engagement of panel bundles.



Figure 5.6a

WARNING: USE PADDING OR BLOCKING ON FORKLIFT MASTS TO PROTECT PANEL EDGES AND PREVENT OVERENGAGEMENT INTO ADJACENT BUNDLES!



Figure 5.6b

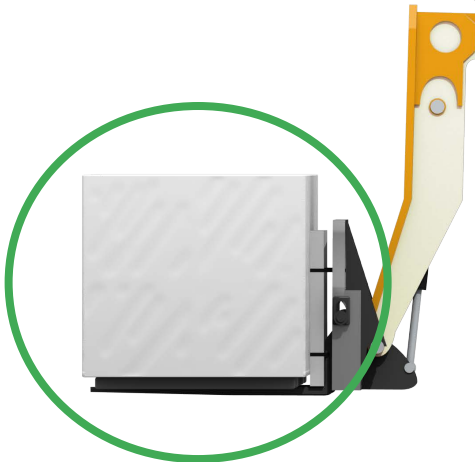

Figure 5.6c



Figure 5.6d

5. MATERIAL HANDLING - Bundles

Forklifts

5.7 Forklift blades must be level and centered under the weight of the bundle.

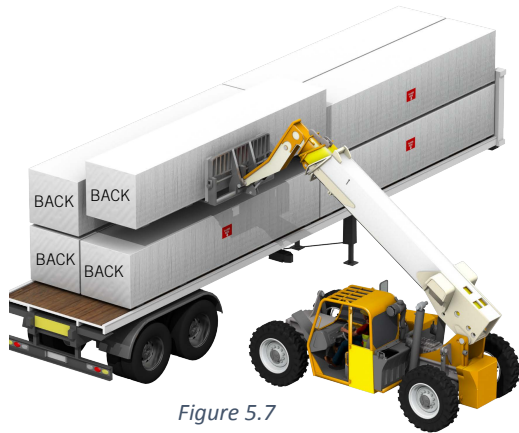

Figure 5.7

WARNING: LIFT ONE BUNDLE AT A TIME

5.8 Longer bundles are pre-marked with two lift points at the factory. Each forklift should straddle one lift point (see figure 5.8)



Figure 5.8

**Two Forklifts
REQUIRED**

**Forklift
HERE**
↓

5.9 Inspect travel route to make sure path is reasonably level, compacted and free of ruts. Move bundles into position as required for efficient installation.

5.10 Secure open bundles with straps before moving with forklifts. Spread forks as far as possible and center under the load. Use caution to prevent excessive bending as damage to panels may result. Avoid bumpy terrain.

WARNING: USE EXTREME CARE WHEN MOVING OPEN BUNDLES, ESPECIALLY THOSE WITH 2-3 INCH PANELS LONGER THAN 20'.

WARNING: WHEN RELOADING BUNDLES, MAKE SURE THE END MARKED "BACK" FACES THE BACK OF THE TRAILER. USE DUCT TAPE TO REPAIR TEARS IN THE BUNDLE WRAP.

5. MATERIAL HANDLING - Bundles

Lifting by crane

5.11 Use wood spreaders (1.5" minimum thickness, width as required for straps) on top and bottom of bundles *at all pick points*.

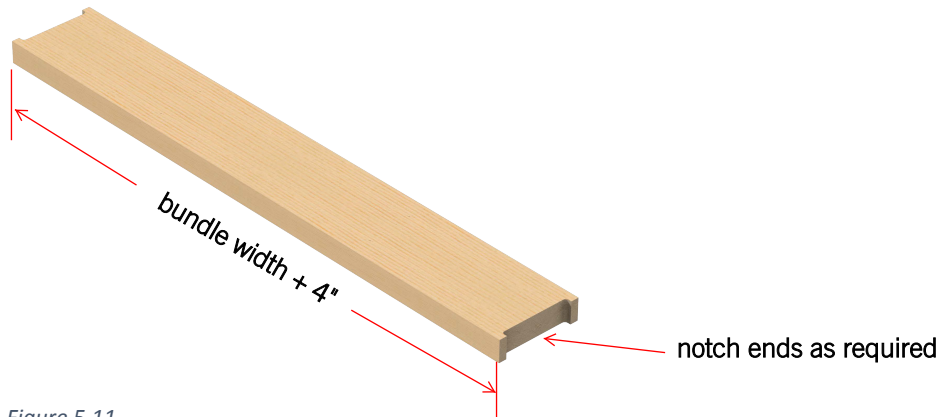
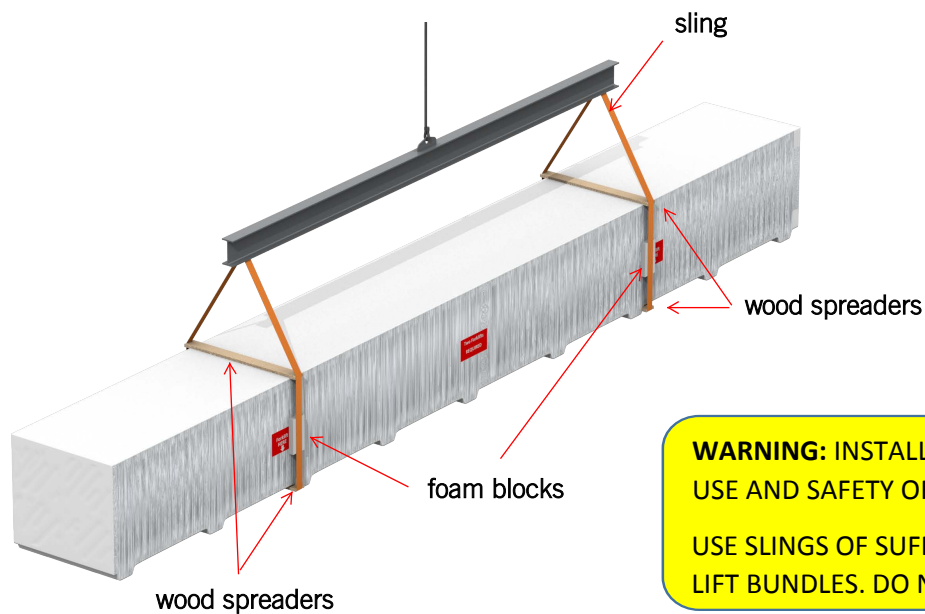

Figure 5.11

5.12 Place foam blocks on sides of bundles at all sling locations as shown in figure 5.12.

5.13 Bundles *under 4,000 lbs. and less than 44'* may be lifted as shown in figure 5.12



WARNING: INSTALLER IS RESPONSIBLE FOR DESIGN, USE AND SAFETY OF RIGGING EQUIPMENT!

USE SLINGS OF SUFFICIENT SIZE AND STRENGTH TO LIFT BUNDLES. DO NOT USE CABLES OR CHAINS!

Figure 5.12

5. MATERIAL HANDLING - Bundles

Lifting by crane

5.14 Bundles over *4,000 lbs. and less than 44'* may be lifted as shown in figure 5.14

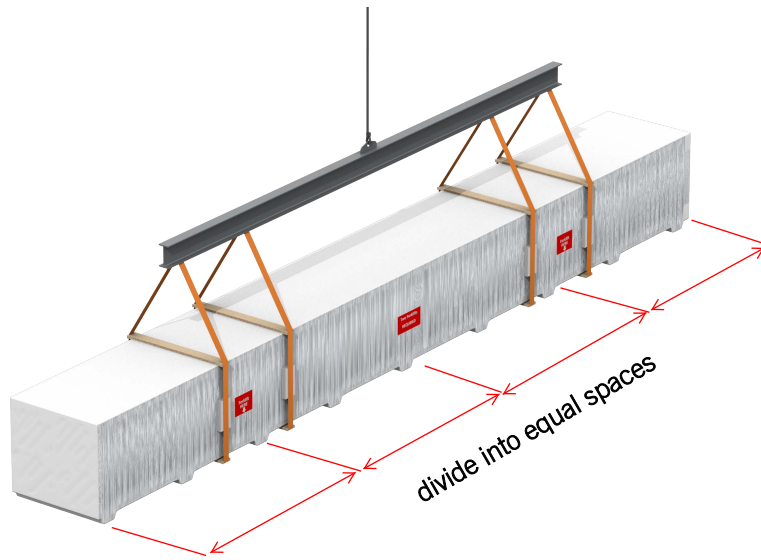

Figure 5.14

5.15 Bundles over *4,000 lbs. and/or over 44'* may be lifted as shown in figure 5.15

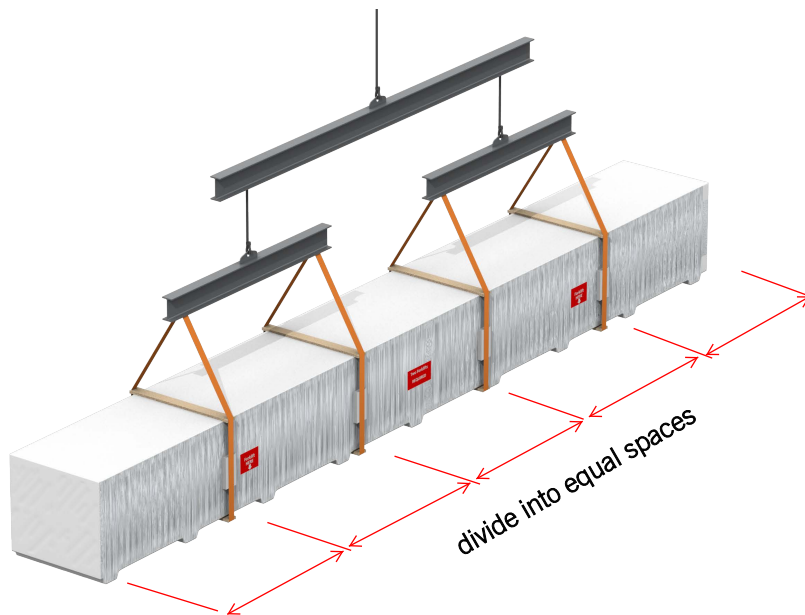
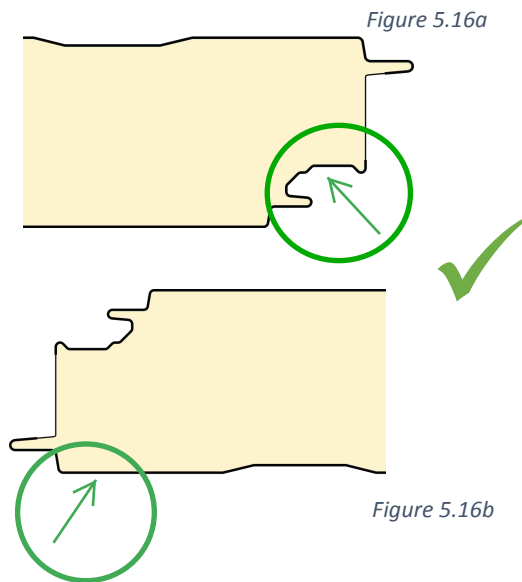

Figure 5.15

5. MATERIAL HANDLING - Individual Panels

Manual Lifting

5.16 Lift panels from here...



NOT from here...

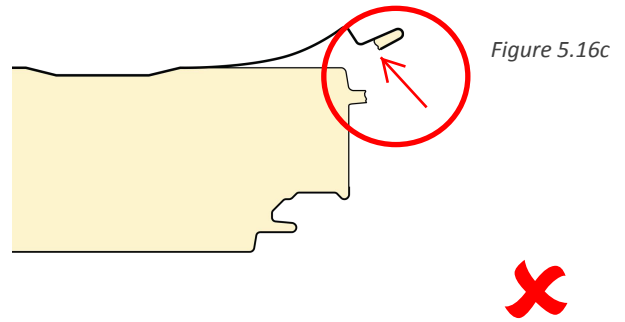

5.17 Rotate panels onto the leading edge (side with clip shelf) before carrying. Use foam blocks (from bundles) to prevent panel edge damage.

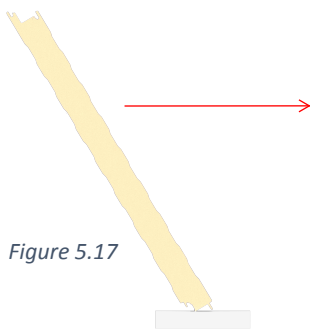

WARNING: TO AVOID SCRATCHING, DO NOT SLIDE PANELS OFF BUNDLES – ALWAYS LIFT THEM.

5.18 Carry panels on edge with sufficient manpower to prevent straining.

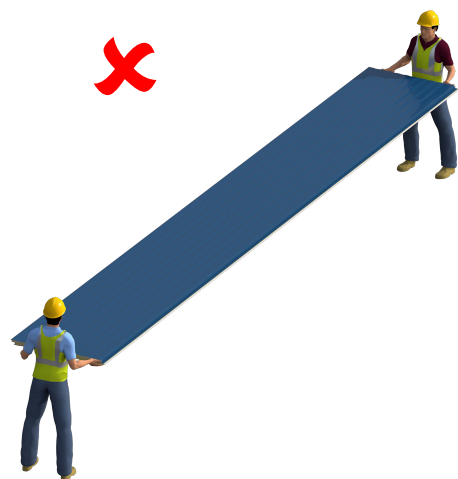
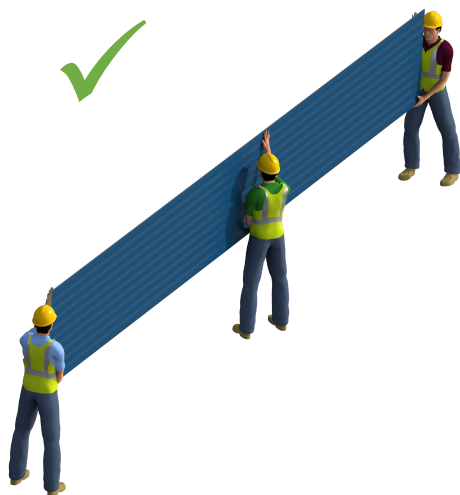

Figure 5.18a

Figure 5.18b

5. MATERIAL HANDLING - Individual Panels

Clamping Devices *(not by Metl-Span)*

5.19 Verify clamping device is securely attached to panels and of sufficient capacity for panel lifting.

5.20 Rotate panel on edge (see 5.17), and lift per figures 5.20a and 5.20b.



Figure 5.20a

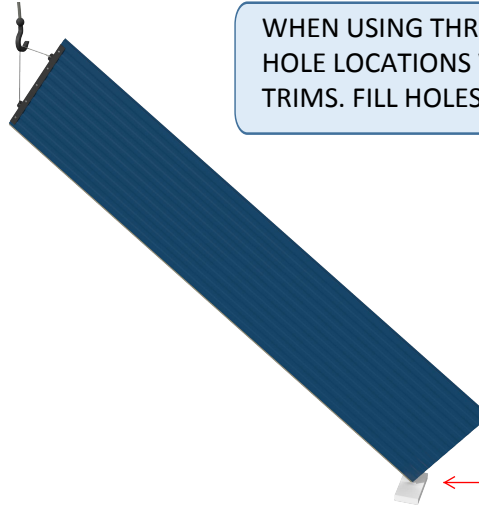

Figure 5.20b

WHEN USING THROUGH BOLTS MAKE SURE HOLE LOCATIONS WILL BE CONCEALED BY TRIMS. FILL HOLES WITH EXPANDABLE FOAM.

Foam blocking

5.21 Set panel in place as shown in figure 5.21a, remove clamp, engage and secure panel.

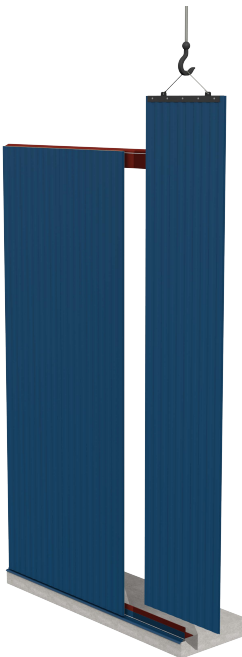

Figure 5.21a

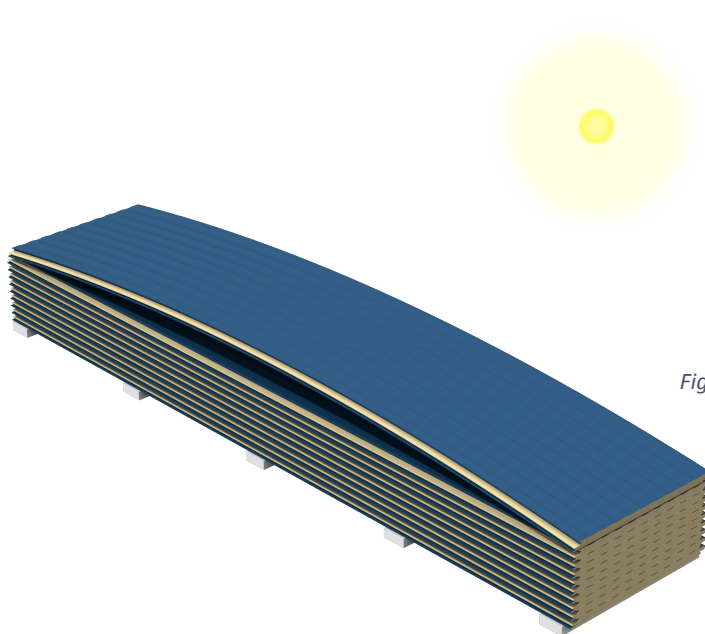

Figure 5.21b

PANELS EXPOSED TO DIRECT SUNLIGHT MAY EXHIBIT THERMAL BOW WHICH CAN PREVENT PROPER ENGAGEMENT. MOVE PANELS TO SHADED AREA OR FLIP THEM OVER TO EXPOSE COOL SIDE TO SUNLIGHT FOR APPROXIMATELY 15 MINUTES.

WARNING: PICKING PANELS FLAT OFF THE BUNDLE WITHOUT THE USE OF VACUUM LIFTING EQUIPMENT AND PROPER OUTRIGGERS IS **NOT** RECOMMENDED!

5. MATERIAL HANDLING - Individual Panels

Vacuum Lifting

5.22 Panel installation time is typically reduced when using vacuum lifting equipment. Equipment must be designed for panel lengths, weights and profiles to be lifted – *verify the requirements of your specific project with your lifting equipment supplier.*

Rotaboy and Cladboy – contact Automak Assembly Inc. at (219) 310-8458*

www.automakassembly.com

Wood's POWR-GRIP® – contact Woods Powr-Grip Co., Inc. at (406) 628-8231*

www.wpg.com



Figure 5.22

**provided for informational purposes only, and does not imply specific endorsements*

6. STORAGE AND STAGING

6.1 Panels should be stored in secure location(s), on level ground that is well drained and free from standing water.

6.2 Elevate one end of panel bundles to provide adequate drainage - use graduated blocking under bundle bearing pads as required (figure 6.2).

6.3 Slit bottom wrapping as shown for ventilation (figure 6.3).

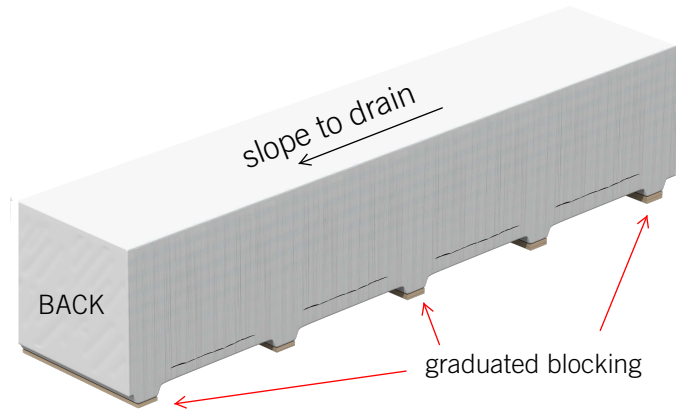

Figure 6.2



Figure 6.3

6.4 Cover opened bundles at the end of the day with a tarp. Secure the bundle with straps to protect against weather damage.

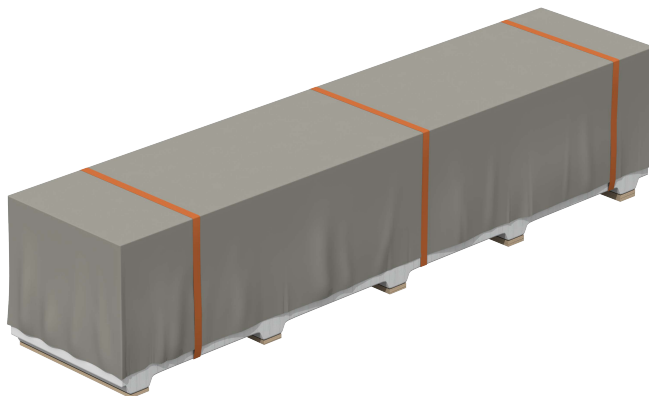

Figure 6.4

WARNING: DO NOT OVERTIGHTEN STRAPS AS DAMAGE TO PANELS MAY OCCUR. USE PROTECTIVE EDGE PADS.

WARNING: KEEP PANELS A SAFE DISTANCE FROM OTHER TRADES THAT ARE TORCHING, CUTTING, WELDING OR PAINTING.

6.5 Items on bundle report match panel callouts on Metl-Span installation drawings. Use this info to stage panels.

JOB NUMBER		PACKAGE NUMBER		
63210		2-1		
CUSTOMER NAME: METL-SPAN		PANEL: 3CF42M/M		
JOB NOTE S: RE: BUILDER XXXX PO # 123456		FACE 1: Brita Red 434R843 Kyear 500 Non-directional Embossing 26 Gauge		
SPECIAL REQUIREMENTS: LEED (BAA) Compliant		FACE 2: Igloo White P8W0532 Polyester Non-directional Embossing 22 Gauge		
P.O. Number: TEST JOB				
CAULKING REQUIREMENT:	EXTERIOR:	INTERIOR:	PHASE NUMBER: 1 OF 1	
ITEM NUMBER	ITEM DESC	PANEL LENGTH	QUANTITY	EXTRA
1	W1	16'- 0"	3	0
2	W2	15'- 6"	3	0
3	PH1	15'- 4"	3	0
4	PH2	15'- 0"	1	1
OPERATOR:		SHIFT:	PROD. DATE: 04/01/15	TIME: 7:12 am
		TOTAL PACKAGED: 11		

Figure 6.5

7. PANEL CUTTING

7.1 Personnel cutting panels should always wear safety glasses, gloves and long sleeve shirts.

7.2 Panel cutting should take place *prior* to installation when possible.

7.3 Use the following cutting tools to avoid panel damage:

- ✓ Circular saw with carbide tipped metal cutting blade
- ✓ Insulated metal panel saw
- ✓ Band saw with metal cutting blade



7.4 Use care when using reciprocating saws to avoid panel delamination: make sure the blade is sharp and let the saw cut at its own pace - do not force.



7.5 Do NOT use abrasive saws to cut panels.

- ✗ Abrasive saws



**WARNING: USE OF ABRASIVE SAWS/
GRINDER BLADES WILL DAMAGE THE
PAINT FINISH AND THE METAL FACINGS!**

7.6 For small penetrations, cut each panel face with a portable router, then cut the foam with a serrated knife.



7.7 Metal flashings may be cut with power snips, nibblers or hand snips.



7. PANEL CUTTING

7.8 Place the panel on padded sawhorses with the interior side up.

7.9 Wipe mud and debris off panel face to be cut with clean rag.

7.10 Mark cut line with chalk or washable felt tip marker (figure 7.10).

7.11 Masking tape may be applied on both sides of cut line to minimize panel scratching.

7.12 Recheck measurements and cut with appropriate tool per 7.3, 7.4.

7.13 Remove burrs at cut edges with deburring tool.

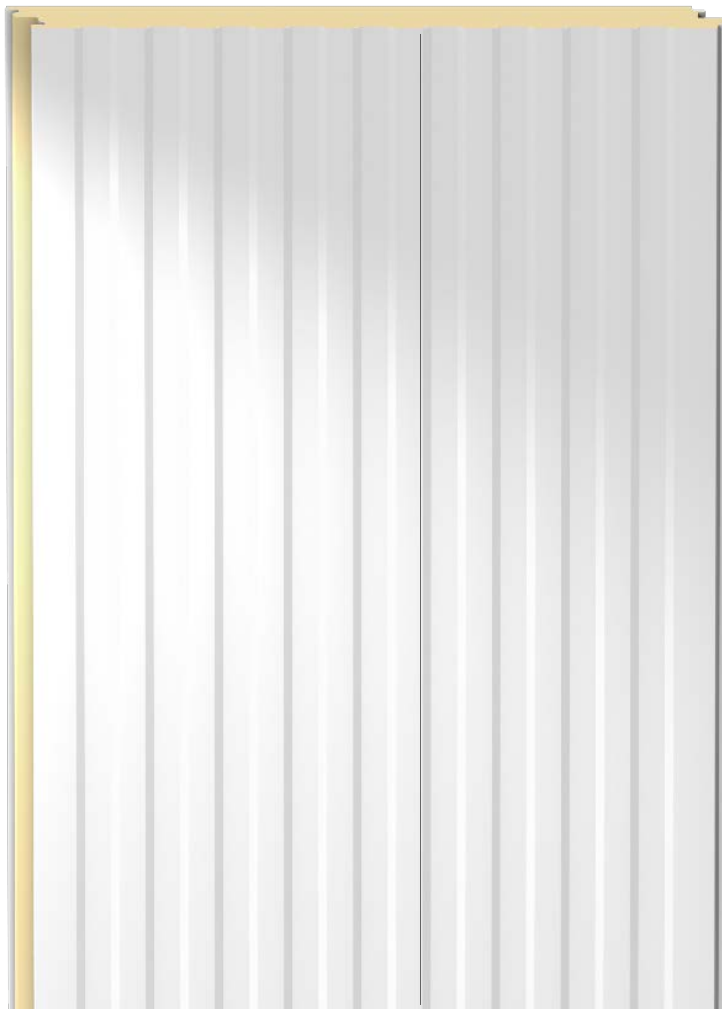

TEST FIT PANEL BEFORE
INSTALLING JOINT SEALANT!

CHECK BLADE SHARPNESS OFTEN
WHEN CUTTING TUFF COTE® PANELS
AS THE FINISH CONTAINS ABRASIVES.

WARNING: TO PREVENT DAMAGE TO
THE PAINT FINISH REMOVE ALL METAL
SHAVINGS FROM PANEL SURFACES AFTER
CUTTING!

Figure 7.10

7. PANEL CUTTING

Framed Openings

7.14 For panels located at framed openings where 50% or more of panel width is removed:

- a. mark cut lines on BOTH panel faces
- b. drill 1/4" holes at corner locations
- c. cut the exterior face to a depth of 1/4"
- d. flip panel over and cut interior face to a depth of 1/4"
- e. cut all the way through panel sidejoints at the framed opening area
- f. lift panel into place, set on bottom support
- g. cut foam with serrated knife and remove panel section
- h. engage panel and secure with fasteners
- i. de-bur and remove metal shavings

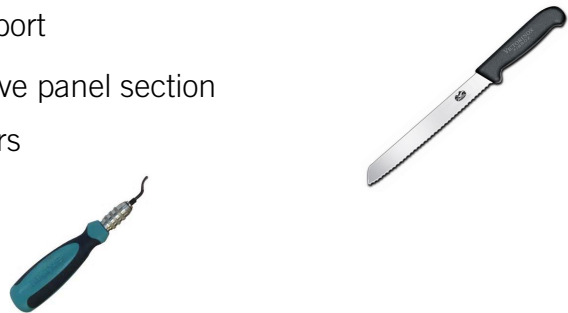

panel exterior

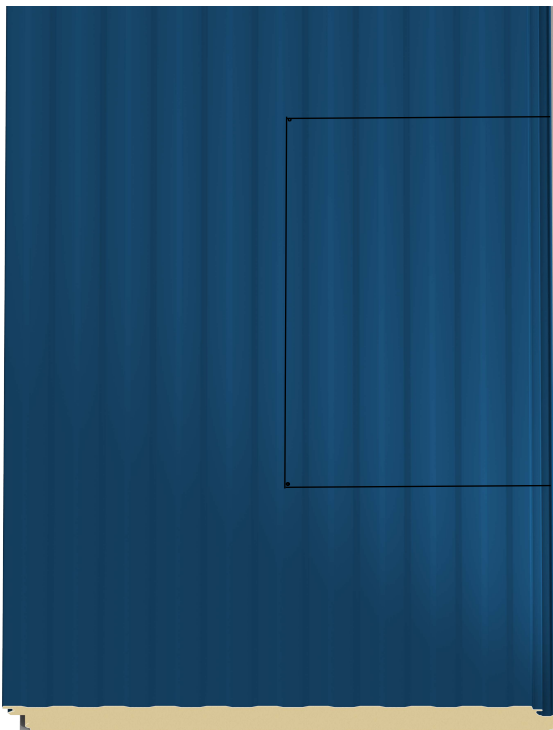

Figure 7.14a

panel interior

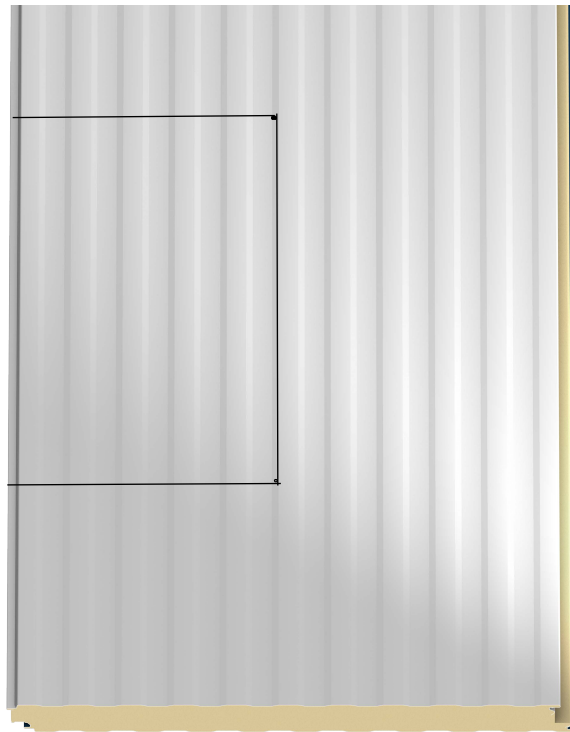

Figure 7.14b

CUT METAL FACINGS ONLY - DO NOT CUT FOAM CORE UNTIL PANEL IS LIFTED INTO PLACE!

8. PANEL SEALANT

WARNING: THE TYPICAL AIR/VAPOR BARRIER LOCATION FOR COMMERCIAL/INDUSTRIAL PROJECTS IS THE LINER (INTERIOR) SIDE JOINT. HOWEVER, THE PROJECT ARCHITECT IS RESPONSIBLE FOR DETERMINING THE ACTUAL VAPOR BARRIER LOCATION, WHICH MAY VARY FROM THE DETAILS SHOWN IN THIS GUIDE.

8.1 Joint must be clean and dry before applying sealant.

8.2 Apply continuous non-curing (non-skinning) butyl sealant to the interior panel joint with a bead size of approximately ¼” as shown in figure 8.2. Sealant should provide continuous seal between the tongue and groove, but not overflow onto panel faces.

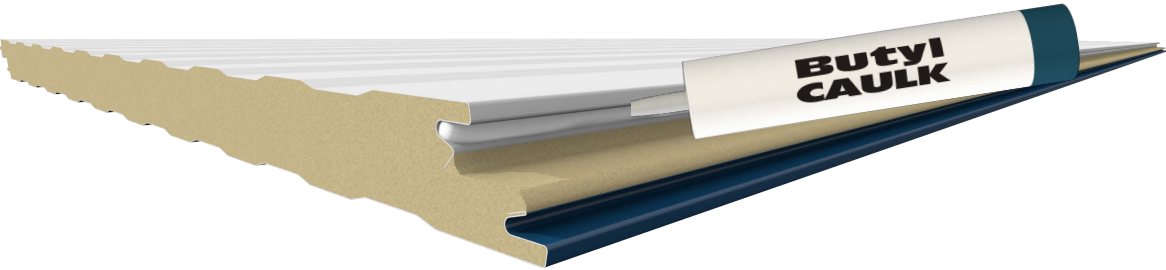

Figure 8.2

COLD WEATHER = STORE BUTYL IN A WARMING BIN UNTIL READY FOR USE
HOT WEATHER = STORE BUTYL IN THE SHADE AND OUT OF DIRECT SUNLIGHT

8.3 Inspect factory applied sealant (if any) for consistent bead size - add sealant as required.

REMOVE SEALANT FROM PAINTED PANEL FACES BY USING WD-40 OR MINERAL SPIRITS APPLIED WITH A CLEAN COTTON RAG.

FOR TUFF-COTE PANELS CONTACT METL-SPAN FOR SEALANT REMOVAL INSTRUCTIONS.

9. PANEL FASTENERS

WARNING: REFER TO PROJECT INSTALLATION DRAWINGS FOR FASTENER TYPES AND REQUIRED FASTENING PATTERNS!

Self-drilling, self-tapping fasteners contain a built-in drill point, and do not require pre-drilling. They are the quickest and easiest way to attach insulated metal panels to light-medium gauge supports.



Figure 9.1a

B point fasteners are used to attach panels to medium-heavy gauge supports that are difficult or not possible to drill with self-drilling type fasteners. They require a two-step operation:

1. pre-drill holes through panels and structure
2. insert fastener and tighten

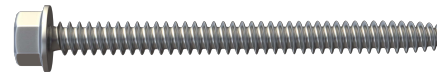

Figure 9.1b

Suggested fastener driving speeds:

Carbon, Zinc Plated and 410 Stainless Steel: 1,800 rpm

304 Stainless Steel: 1,000 rpm

USE A TORQUE CONTROL OR DEPTH SENSING NOSE PIECE FOR PROPER FASTENER PERFORMANCE.

Recommended self-drilling, self-tapping types for various support thicknesses (1/4" diameter):

Support thickness	Type	Threads per inch
18 gauge (.048)	#2, #3	14
16 gauge (.060)	#2, #3	14
14 gauge (.075)	#2, #3	14
12 gauge (.105)	#3	14
1/8" (.125)	#3	14
10 gauge (.134)	#3	14
3/16" (.187)	#5	20 minimum
1/4" (.250)	#5	24
3/8" (.375)	#5	24
1/2" (.500)	#5	24

Pilot Hole Sizes for 1/4" diameter B point fasteners:

Support thickness	Bit Size	Threads per inch
18 gauge (.048)	3/16"	14
16 gauge (.060)	#9 (.196)	14
14 gauge (.075)	#9 (.196)	14
12 gauge (.105)	#7 (.201)	14
1/8" (.125)	#2 (.221)	14
10 gauge (.134)	#2 (.221)	20
3/16" (.187)	#2 (.221)	20 minimum
1/4" (.250)	#1 (.228)	24
3/8" (.375)	#1 (.228)	24
1/2" (.500)	.234	24

10. CLEANING

WARNING: DO NOT USE WIRES BRUSHES, STEEL WOOL OR ANY OTHER ABRASIVE METHODS TO CLEAN PANELS.

10.1 Metal shavings from cutting and drilling should be removed as panels are erected using a soft bristle brush or clean cotton rag.

10.2 For general cleaning, use a low pressure power wash with plain water. If necessary, use carwash soap or a 5% solution of mild laundry detergent (such as Tide). Use a clean cotton rag, sponge or *soft bristle* brush as required. Rinse thoroughly.

10.3 Sealants, grease, tar and wax can be removed from panels and trim by using WD-40 or mineral spirits. Apply to a clean cotton rag, and avoid smearing over a large area. Follow up with general cleaning instructions per 10.2.

10.4 For rust stains, remove the source (typically metal filings), then clean the affected area using one of the following methods: soap and water or Rid O'Rust®.

10.5 Concrete/mortar splatter must be washed off immediately with a high pressure wash and mild detergent.

WARNING: SCRUBBING THE PANELS WHILE MORTAR IS PRESENT WILL LIKELY RESULT IN SCRATCHES TO THE PAINT

11. TOUCH-UP

11.1 Contact Metl-Span Customer Relations for color matched touch-up paint with applicator brush.

11.2 Touch-up paint is for minor scratches only. For deep scratches or larger areas of repair, contact Customer Relations for detailed instructions.

11.3 Clean affected area with a clean cloth, dampened with isopropyl alcohol.

11.4 Air and panel temperatures must be above 50°F before attempting repairs.

11.5 Apply touch-up in the scratch using an artist brush.

11.6 Allow 30-45 minutes for tack free and 24 hours for complete drying.

11.7 For more information regarding touch-up refer to the Owner's Maintenance Manual.

12. INTERIOR TRIM INSTALLATION - BASE

12.1 Re-verify framing alignment per Chapter 3 Framing Alignment.

12.2 Confirm base condition as overhang or notched slab.

12.3 If base angle has not yet been installed, place urethane sealant *under* angle and butyl sealant on *vertical leg* of angle as shown in figure 13.3a (overhung) and 13.3b (if notched slab).

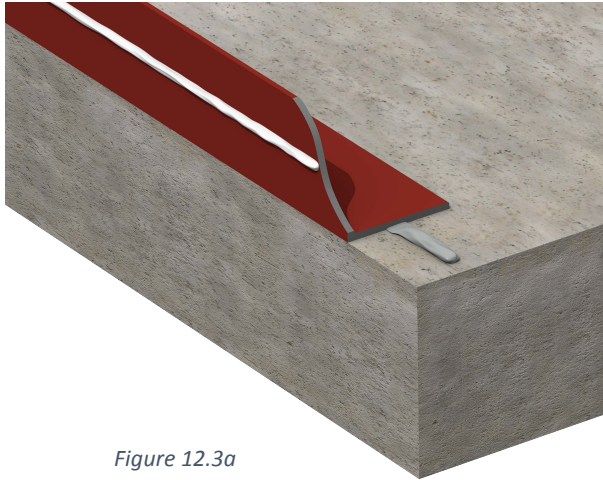

Figure 12.3a

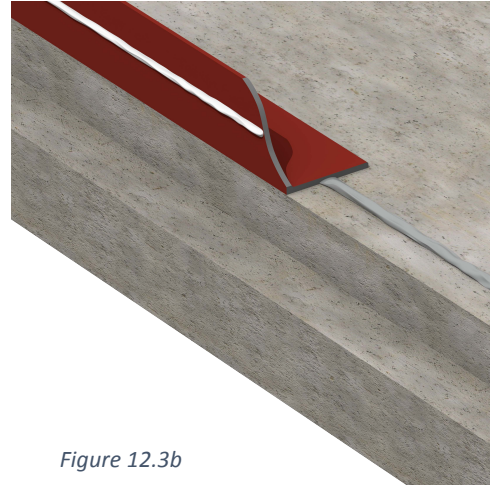

Figure 12.3b

12.4 If base angle is already installed, place sealant as shown in figure 12.4a (overhung) and figure 12.4b (if notched slab).

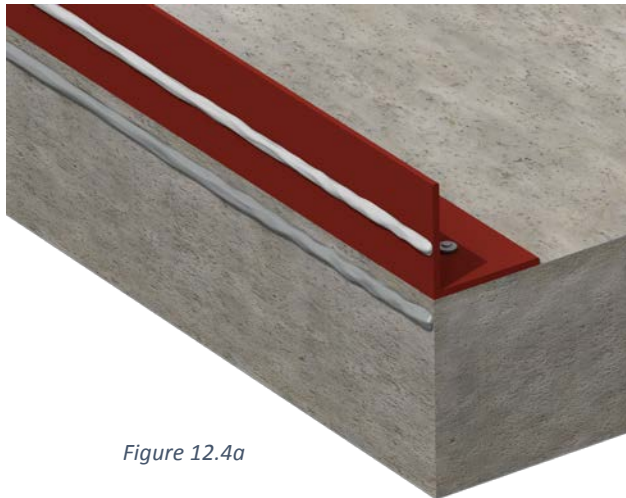

Figure 12.4a

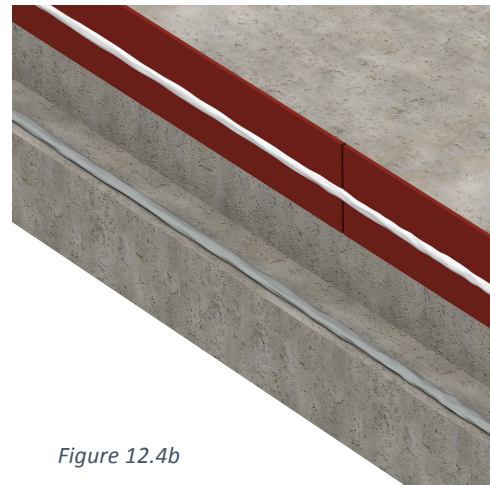

Figure 12.4b

12. INTERIOR TRIM INSTALLATION - BASE

12.5 Attach base flashing to base attachment using #12 pancake stitch fasteners (12" on center).

FOR MORE BASE CONDITIONS SEE
CHAPTER 15 GENERAL DETAILS.

For base conditions matching 12.3:

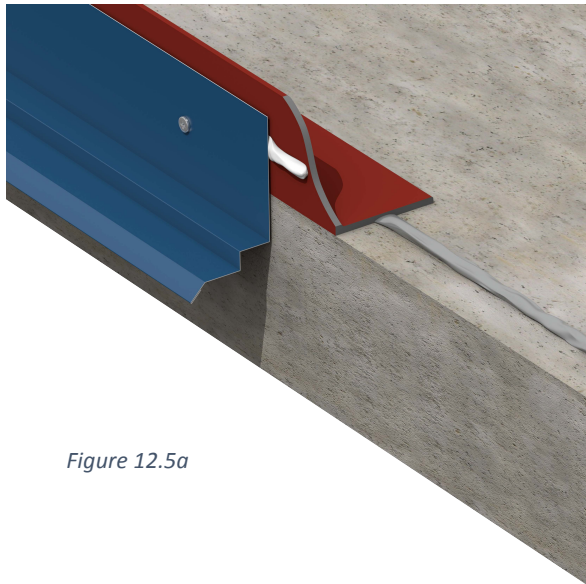

Figure 12.5a

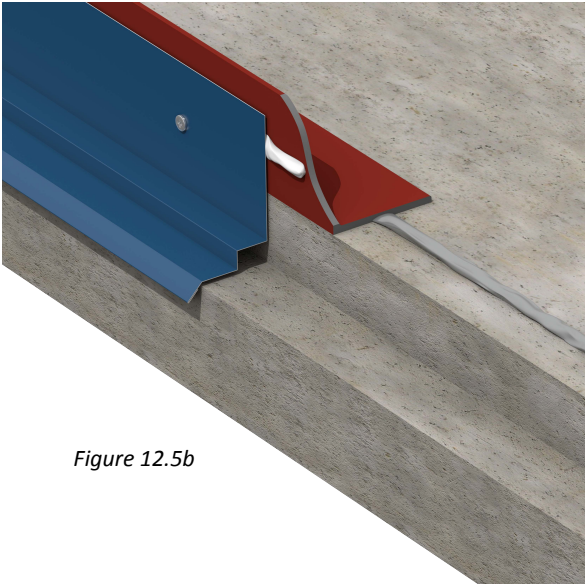

Figure 12.5b

For base conditions matching 12.4

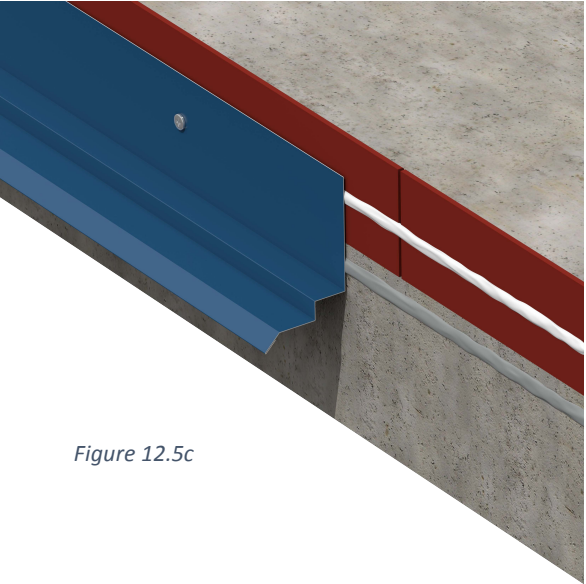

Figure 12.5c

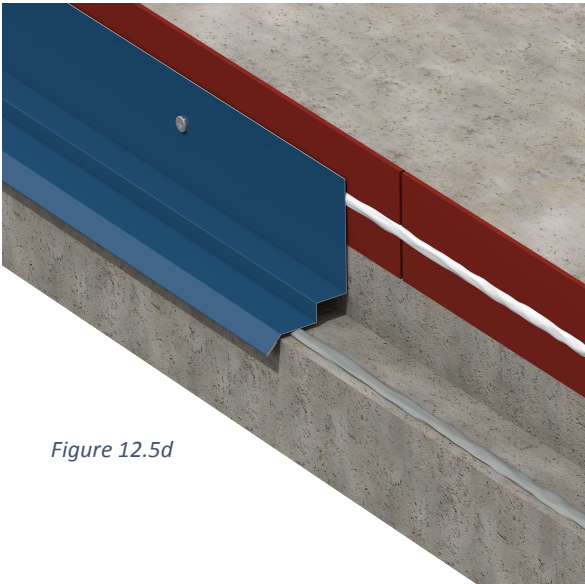

Figure 12.5d

12. INTERIOR TRIM INSTALLATION - BASE

12.6 Lap base flashing with urethane sealant, install 1/8" color matched pop rivets as shown.

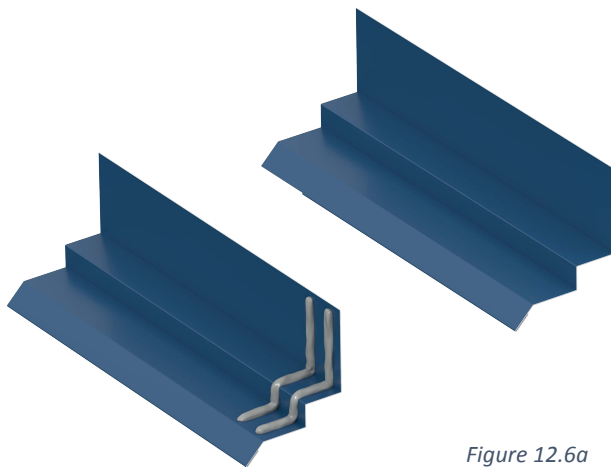

Figure 12.6a

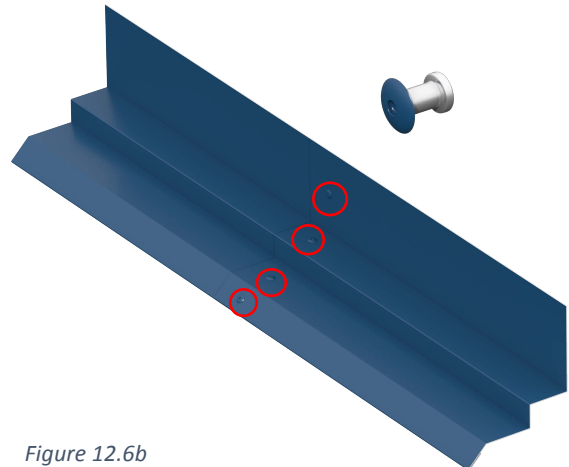

Figure 12.6b

12.7 Cut flashing section at end of wall at 45 degree angle. Notch end of opposing flashing section with tabs that lap underneath. Apply urethane sealant, join pieces together using 1/8" color matched stainless steel pop rivets.

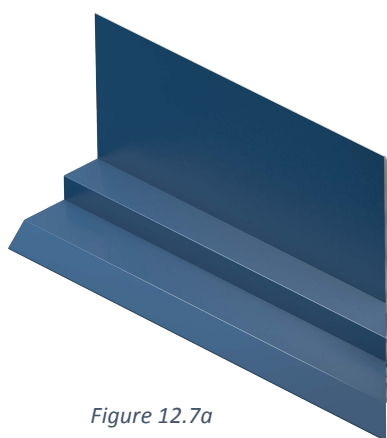

Figure 12.7a

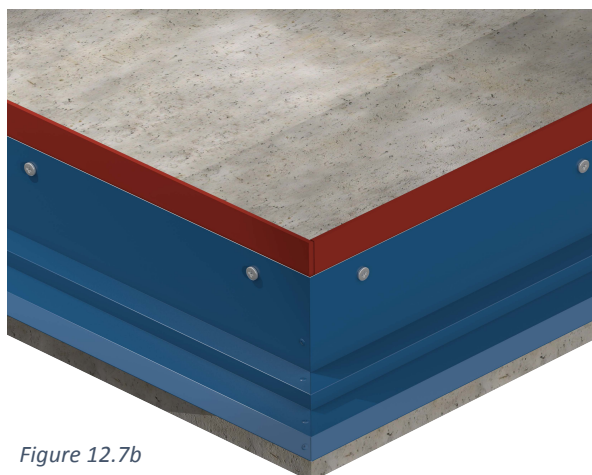
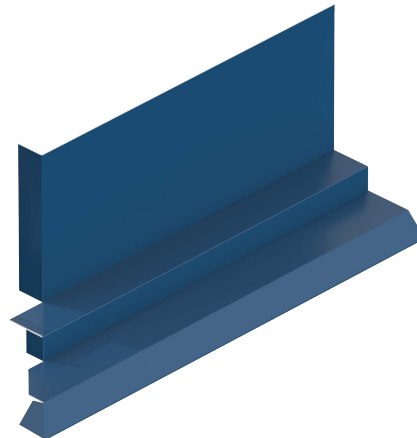

Figure 12.7b

STRAIGHT SLAB EDGE

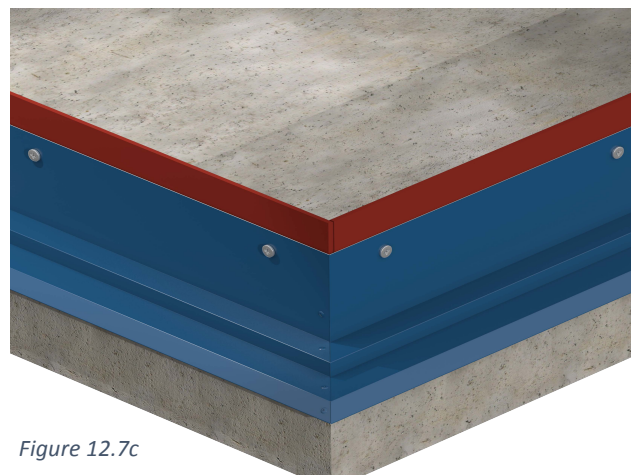

Figure 12.7c

NOTCHED SLAB EDGE

12. INTERIOR TRIM INSTALLATION - CORNERS

12.8 Install interior portion of two piece corner trims using 1/8" stainless steel pop rivets.

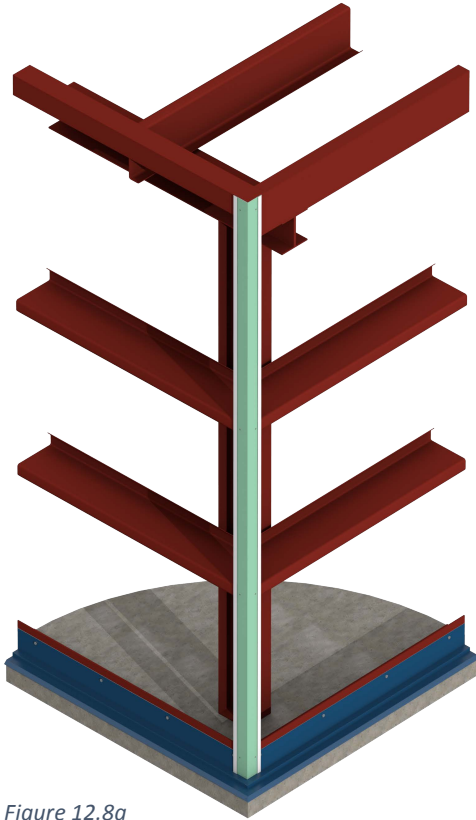

Figure 12.8a

exterior corner

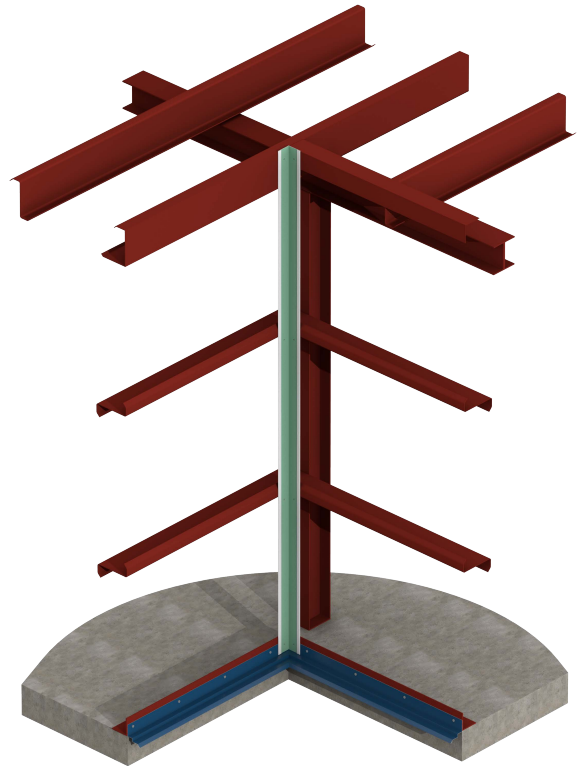

Figure 12.8b

interior corner

12.9 Trim hems 2", apply 2 rows of urethane sealant, lap and fasten with 1/8" stainless steel painted pop rivets.

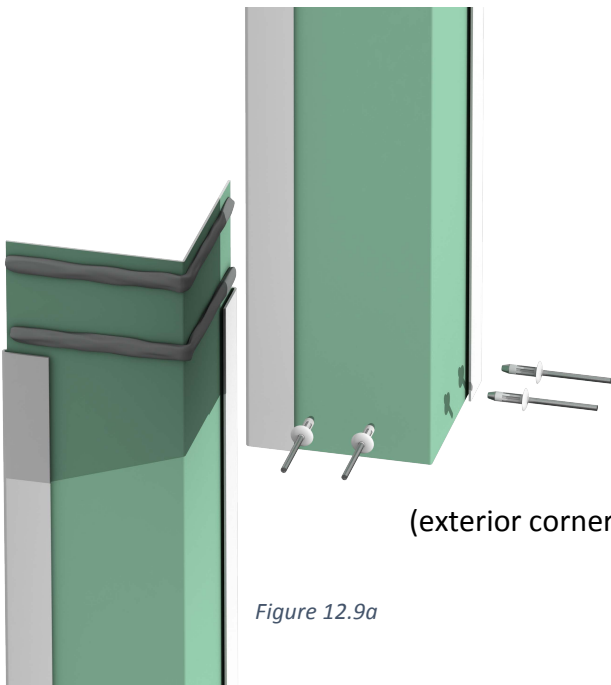

Figure 12.9a

(exterior corner trims)

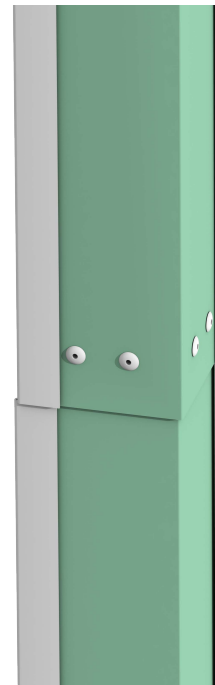

Figure 12.9b

12. INTERIOR TRIM INSTALLATION - FRAMED OPENINGS

12.10 For two piece jambs, apply minimum 1/4" bead of butyl sealant at *head and jambs* of framed openings.

12.11 For one piece jambs, apply minimum 1/4" bead of butyl sealant at *head* conditions only.



Figure 12.10a



Figure 12.11

REFER TO PROJECT INSTALLATION DRAWINGS TO DETERMINE IF ONE OR TWO PIECE JAMB SYSTEM IS REQUIRED.

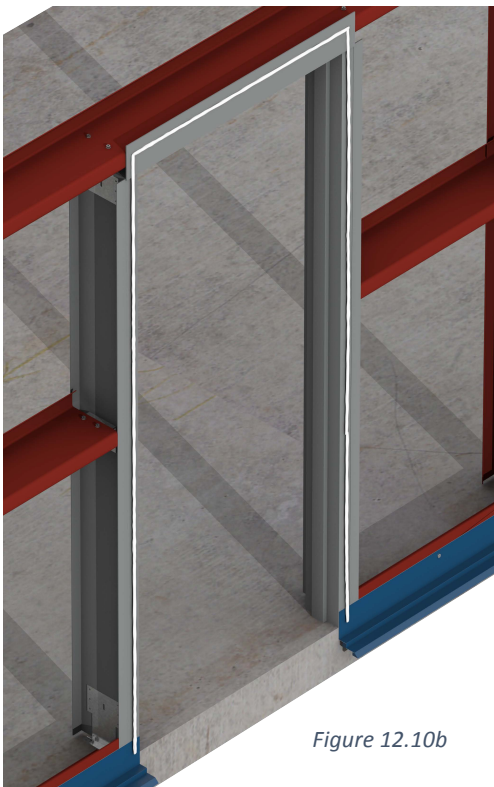

Figure 12.10b



Figure 12.10c

12. INTERIOR TRIM INSTALLATION - FRAMED OPENINGS

12.12 Notch interior head trim at framed opening corners and bend tabs downward at each end.

12.13 For two piece jambs, install interior head and jamb trims with 1/8" stainless steel pop rivets at 12" on center.

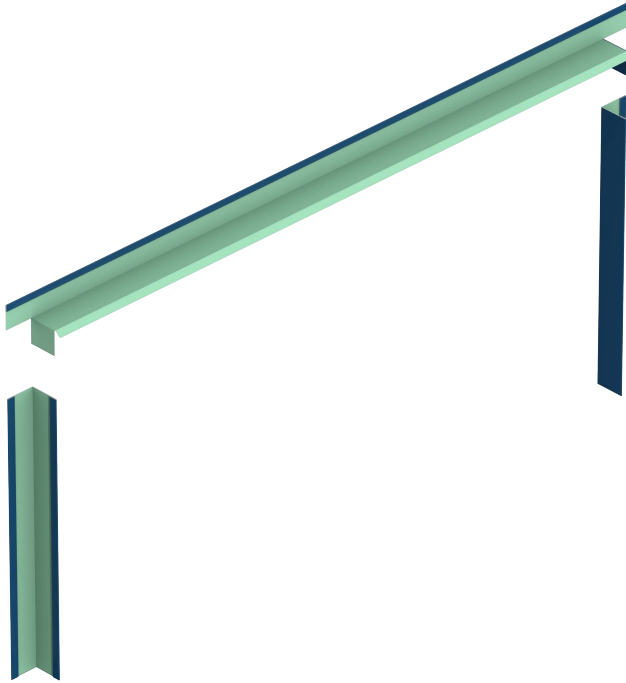

Figure 12.12

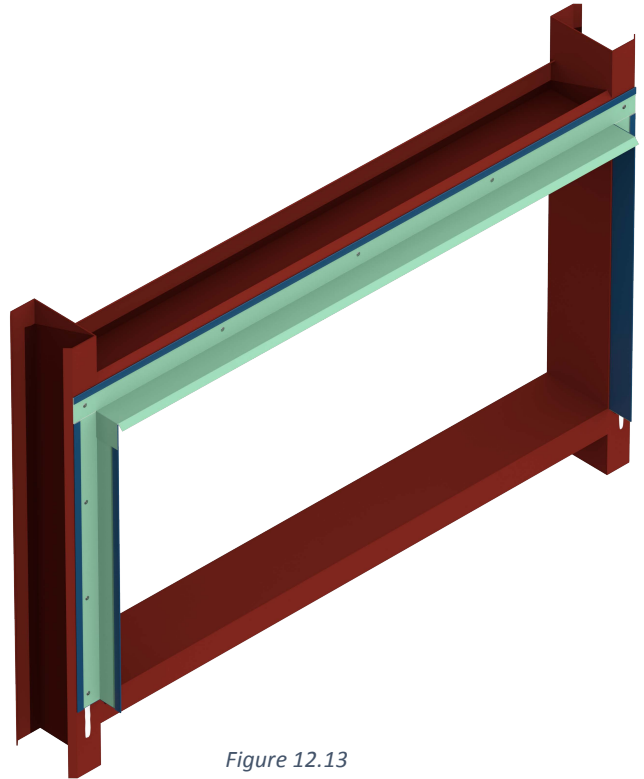

Figure 12.13

TWO PIECE JAMB SYSTEM SHOWN - VERIFY PER PROJECT INSTALLATION DRAWINGS.

12.14 For one piece jambs, install interior head trim only with 1/8" stainless steel pop rivets at 12" on center.

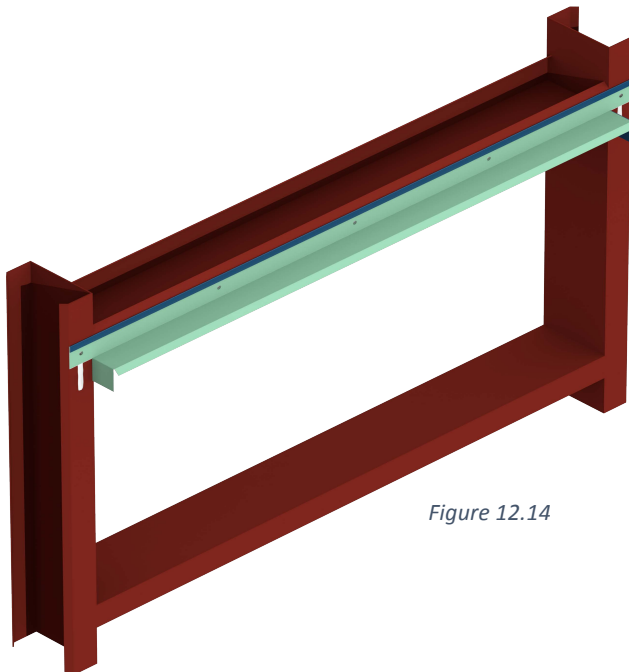

Figure 12.14

12. INTERIOR TRIM INSTALLATION - FRAMED OPENINGS

12.15 Notch interior jamb trims as required at intersection of base flashing.

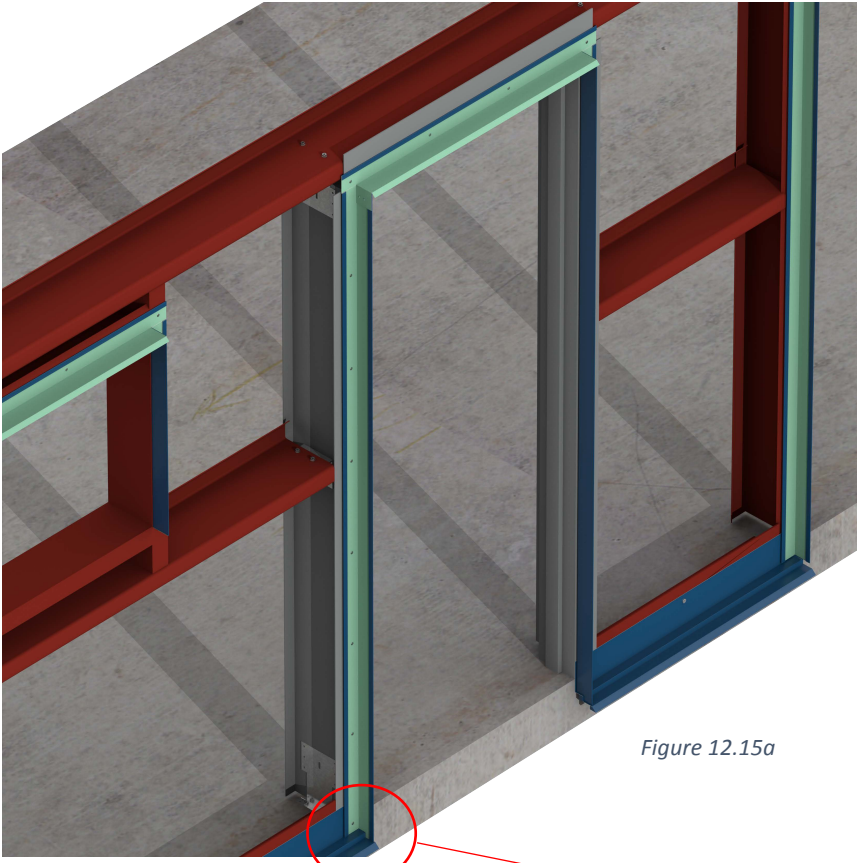

Figure 12.15a

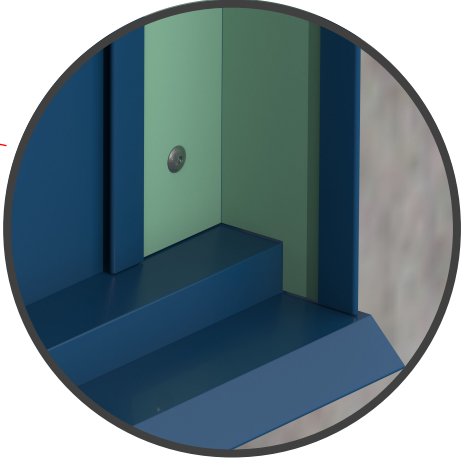

Figure 12.15c

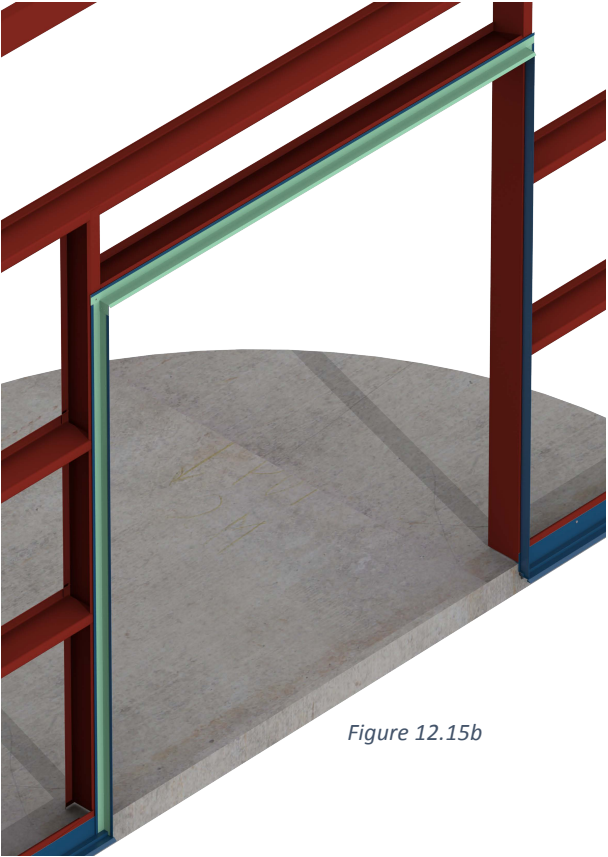

Figure 12.15b

13. PANEL INSTALLATION - SEALANT

13.1 Starting at a building corner, apply 1/4" minimum bead of non-skinning butyl sealant to base flashing, interior corner trim and eave strut (figure 13.1).

13.2 Cut trailing edge of first panel per layout shown on installation drawings (figure 13.2a).

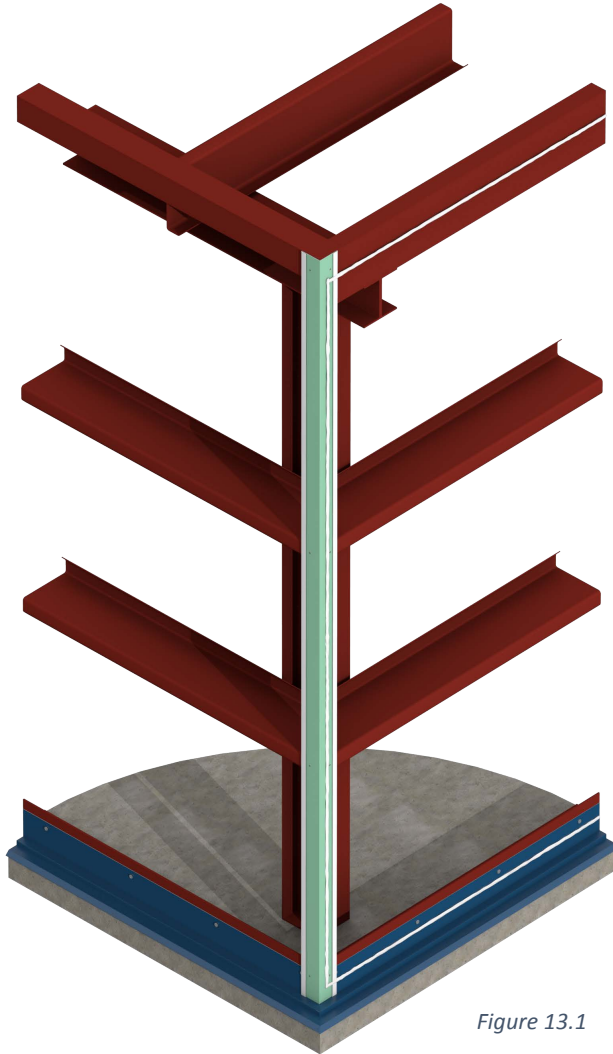

Figure 13.1



Figure 13.2a

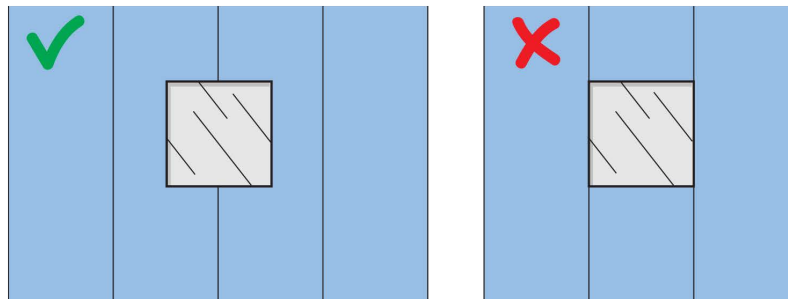

Figure 13.2b

WARNING: ALIGNING PANEL JOINTS WITH JAMBS IS NOT RECOMMENDED DUE TO DIFFICULTY WITH WEATHER SEALING! IF UNAVOIDABLE, CONTACT METL-SPAN FOR RECOMMENDATIONS.

13. PANEL INSTALLATION - STARTER PANEL

13.3 Lift panel into place and firmly set into butyl sealant.

13.4 Place level on leading edge (side with clip shelf), align and fasten trailing cut edge with 1/4" pancake fasteners into structural supports as required per installation drawings.

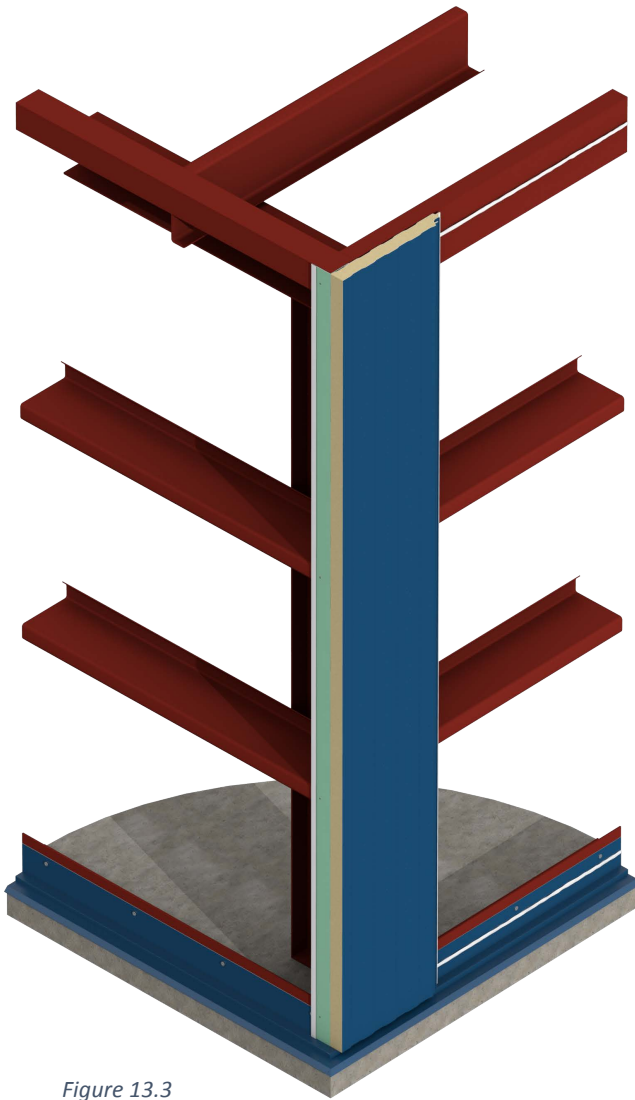

Figure 13.3

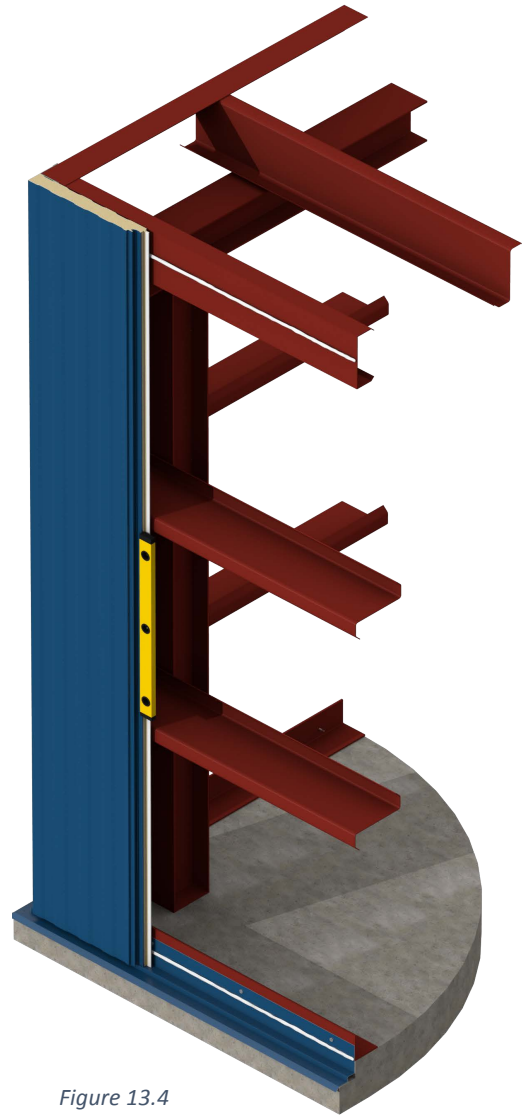

Figure 13.4

WARNING: INSPECT ALL PANELS BEFORE INSTALLING - CHECK FOR DENTS, DEEP SCRATCHES, JOINT DAMAGE AND FACE RIPPLING. DO NOT INSTALL DAMAGED MATERIALS - CONTACT METL-SPAN BEFORE PROCEEDING.

WARNING: DO NOT OVERDRIVE FASTENERS - THIS DAMAGES PANEL APPEARANCE AND CAN CAUSE FASTENER STRIP-OUT.

13. PANEL INSTALLATION - ATTACHMENT

13.5 Attach leading edge of panel to structure per shop drawings (use Metl-Span fastening pattern(s) indicated).

WARNING: REFER TO PROJECT INSTALLATION DRAWINGS FOR FASTENER SIZES, TYPES AND REQUIRED FASTENING PATTERNS!

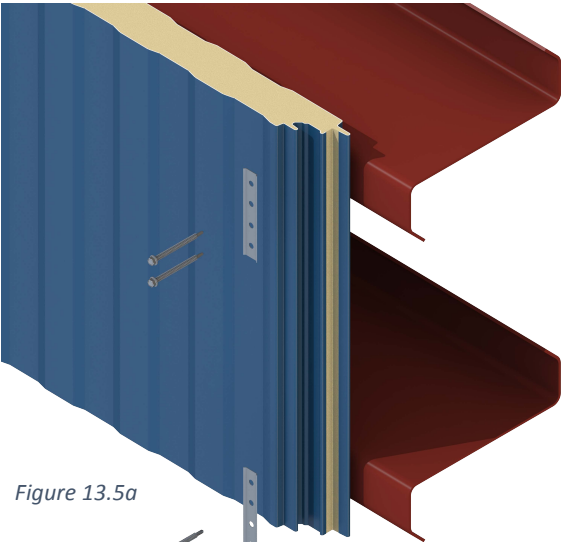

Figure 13.5a

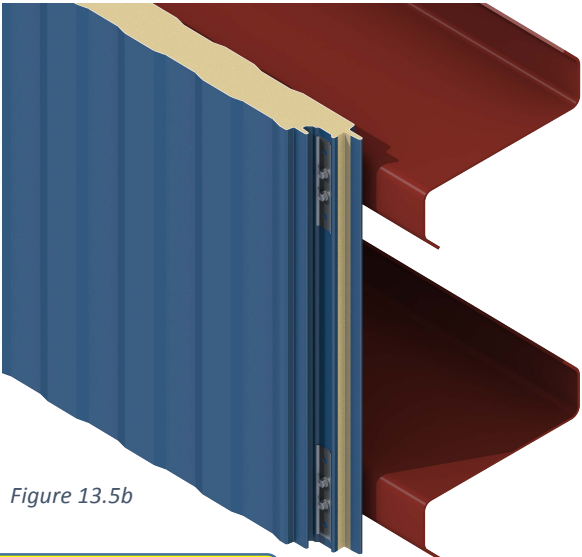

Figure 13.5b

WARNING: INSTALLED CLIPS SHOULD BE SNUG, BUT DO NOT COMPRESS FOAM CORE MORE THAN 1/16".

Figures 13.5a - d are used with Metl-Span Fastening Patterns 1-8 (see pages 71-74 for more information)

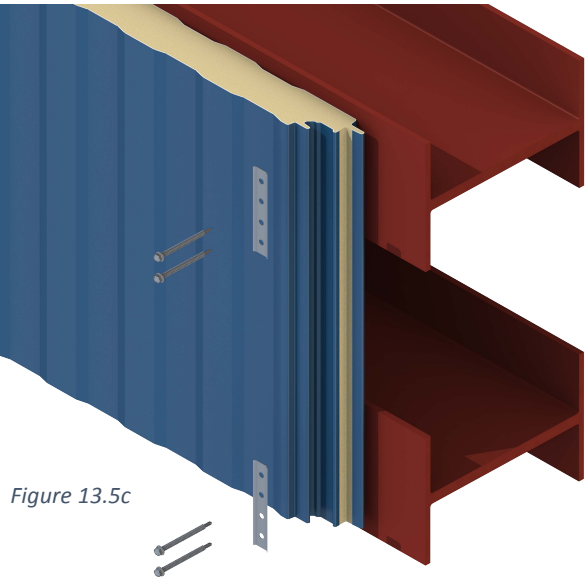

Figure 13.5c

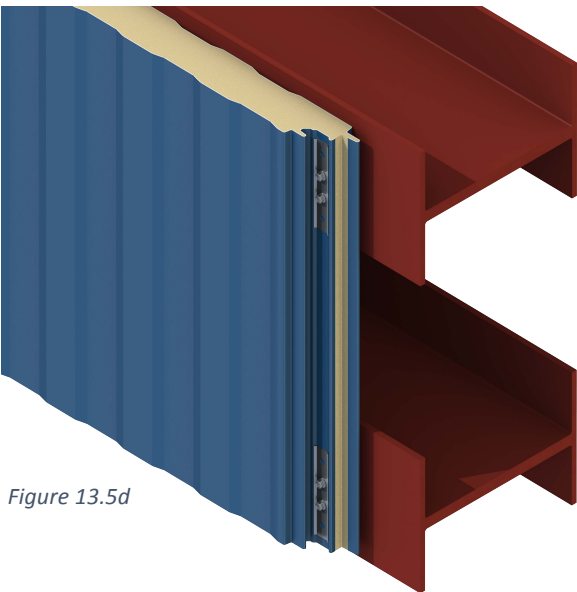
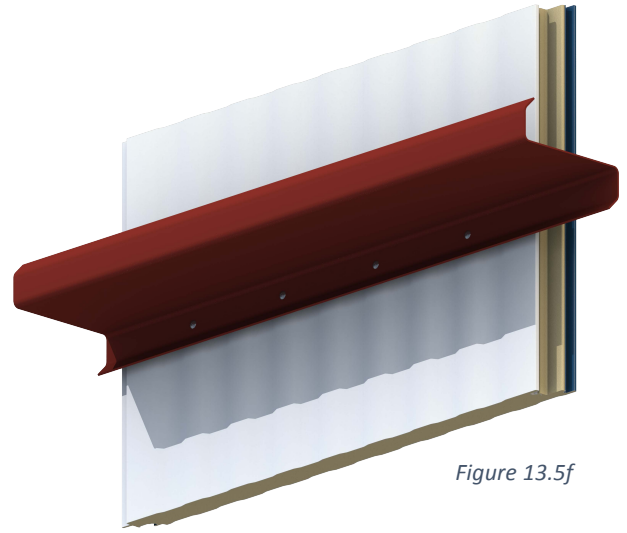
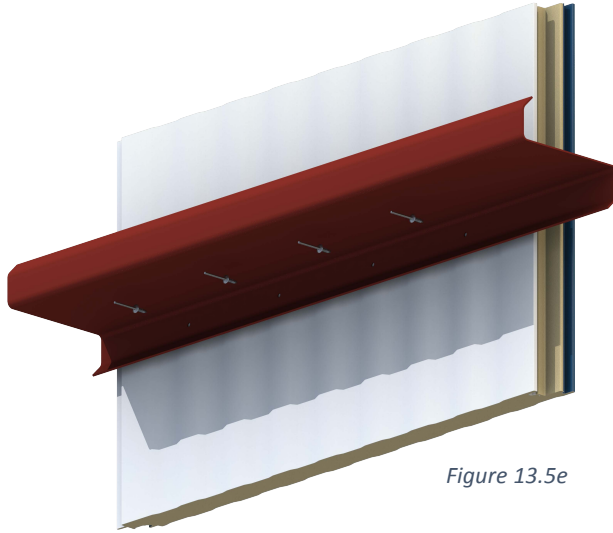

Figure 13.5d

13. PANEL INSTALLATION - ATTACHMENT

WARNING: REFER TO PROJECT INSTALLATION DRAWINGS FOR FASTENER SIZES, TYPES AND REQUIRED FASTENING PATTERNS!



Figures 13.5e and f are *examples* of back fastening used with Metl-Span Fastening Patterns 2-5 (see pages 71-72 for more information)

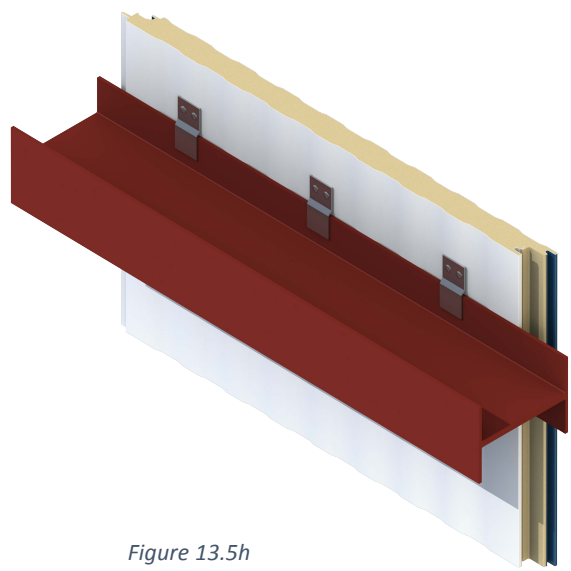
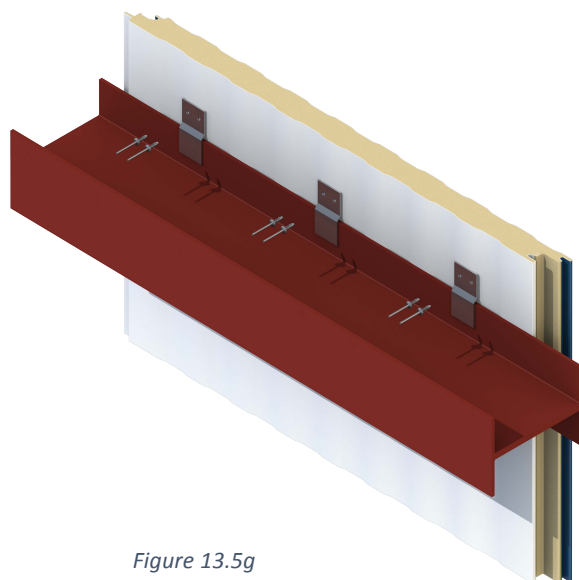

Figures 13.5g and h are examples of back fastening used with Metl-Span Fastening Patterns 6-8 (see pages 72-73 for more information)

13. PANEL INSTALLATION - ATTACHMENT

WARNING: REFER TO PROJECT INSTALLATION DRAWINGS FOR FASTENER SIZES, TYPES AND REQUIRED FASTENING PATTERNS!



Figure 13.5i

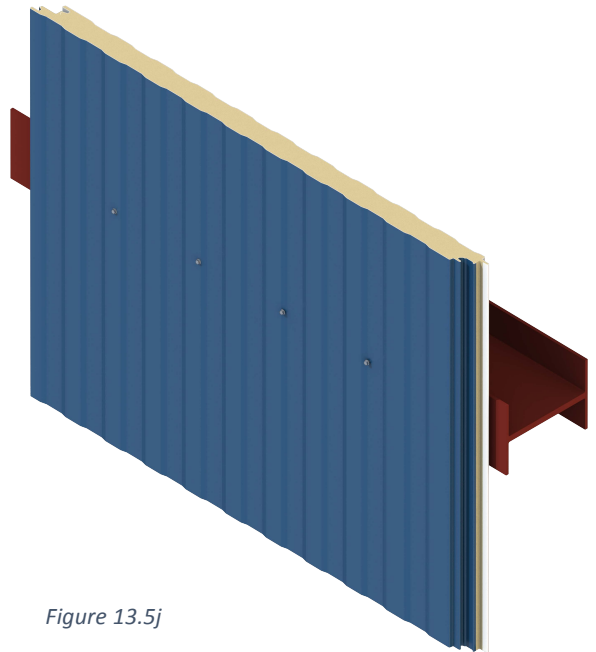

Figure 13.5j

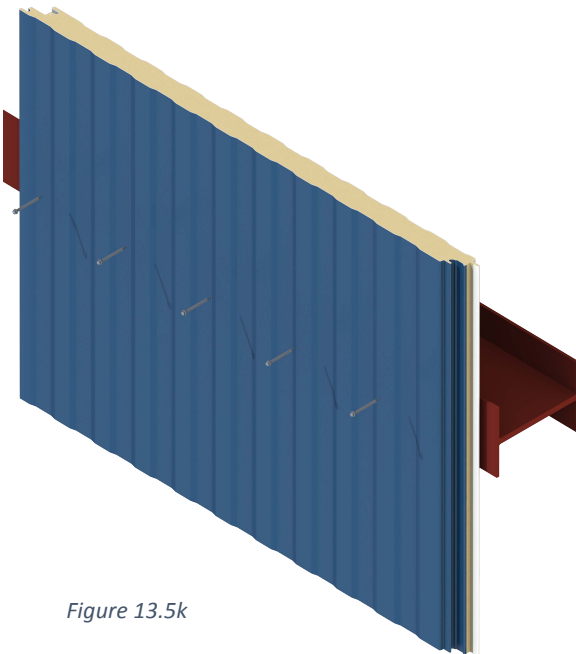

Figure 13.5k

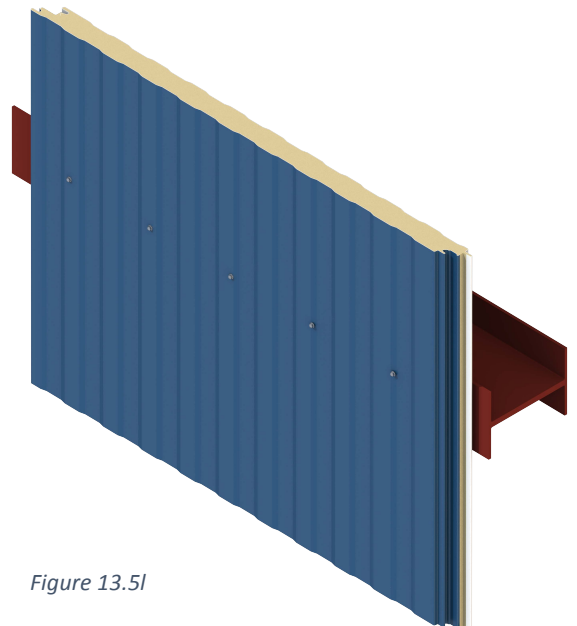

Figure 13.5l

Figures 13.5i - l are used with Metl-Span Fastening Patterns 9-10 (see page 74 for more information)

13. PANEL INSTALLATION - MARRIAGE BEADS

13.6 Marriage beads must be placed at ALL panel terminations.

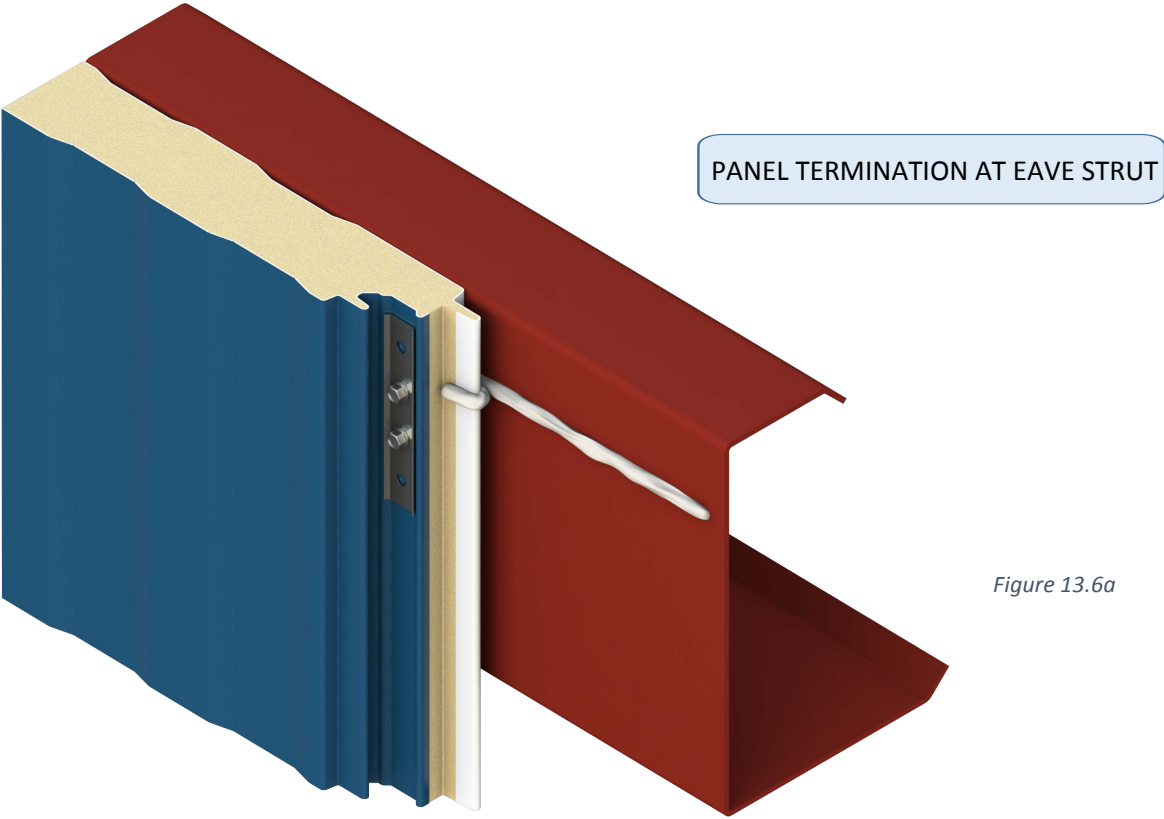

Figure 13.6a

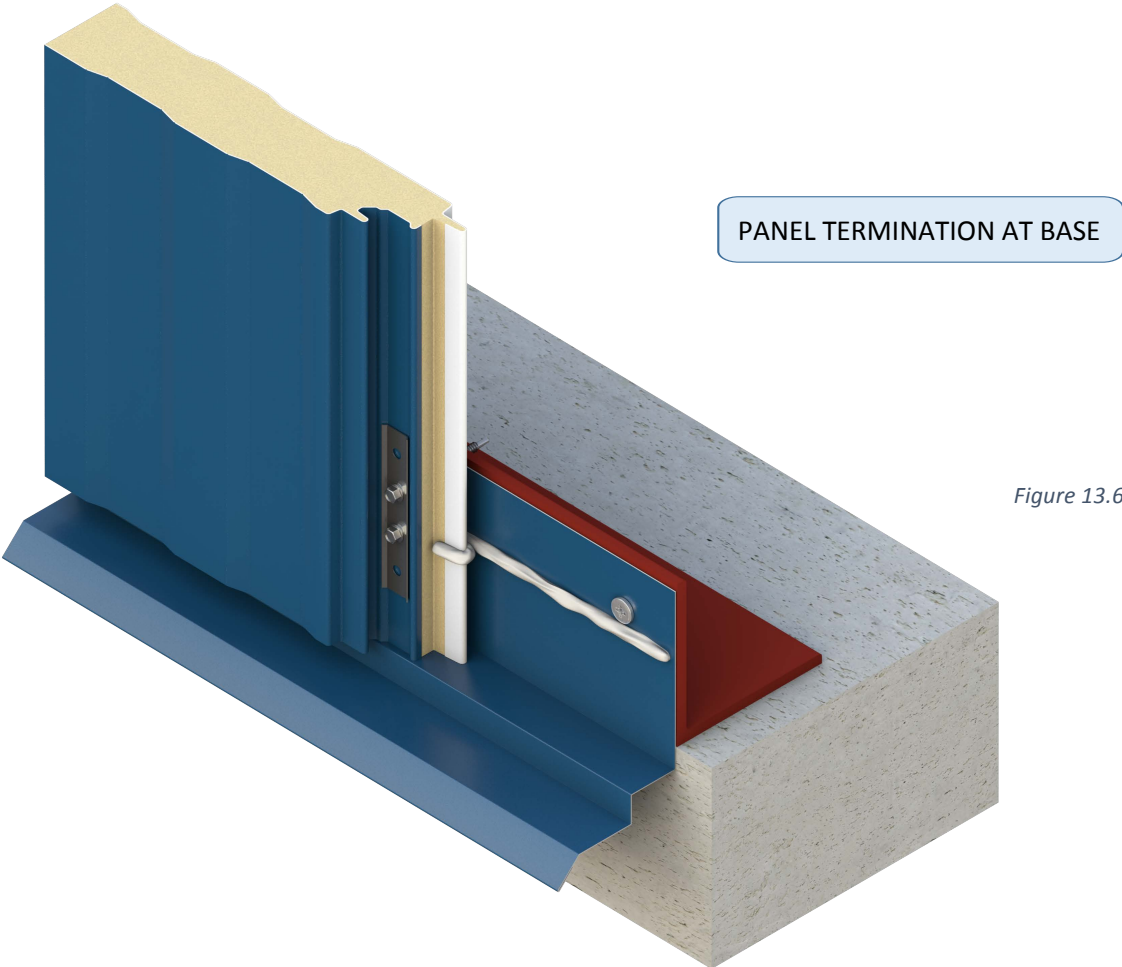
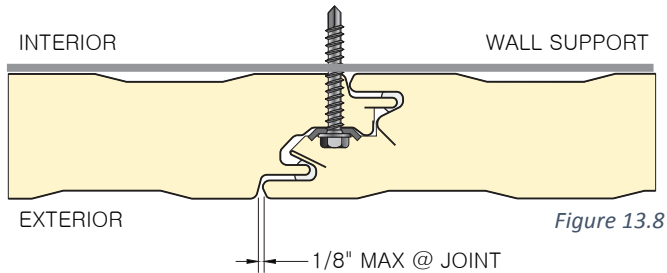

Figure 13.6b

13. PANEL INSTALLATION - SIDEWALL ELEVATION

13.7 Install remaining panels on wall elevation with marriage beads at top and bottom of EVERY panel.

13.8 Verify joint spacing is as shown in figure 13.8.



ACTUAL COVERAGE WIDTH MAY VARY $-1/8''$ TO $+1/8''$ DUE TO PANEL, CAULKING AND STRUCTURAL TOLERANCES!

13.9 Verify vertical alignment at every panel using level on leading edge.

ALL GUIDE GRAPHICS SHOW LEFT TO RIGHT INSTALLATION FOR CLARITY. PANELS MAY BE INSTALLED RIGHT TO LEFT BY ROTATING PANELS 180 DEGREES LENGTHWISE. REFER TO INSTALLATION DRAWINGS FOR PROPER DIRECTION.

13.10 Engage bottom corner of panels first, then allow gravity to rotate panel into position. Hold top of panels 1" off structurals to minimize smearing butyl sealant on eave strut.

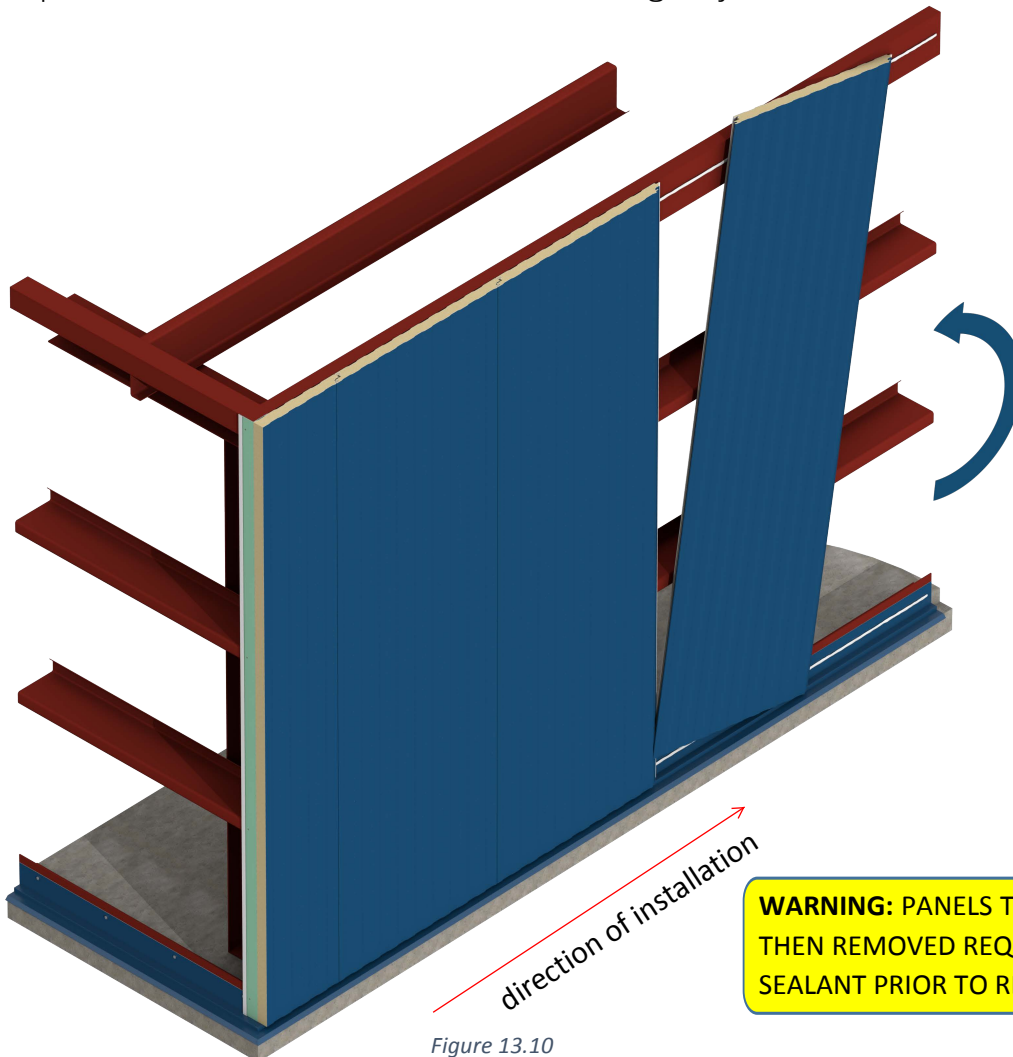

WARNING: PANELS THAT ARE INSTALLED AND THEN REMOVED REQUIRE RE-APPLICATION OF SEALANT PRIOR TO RE-INSTALLING.

Figure 13.10

13. PANEL INSTALLATION - OUTSIDE CORNER

13.11 Cut leading edge of panel P2, trailing edge of panel P3. Attach cut edges of panels at corner with 1/4" pancake fasteners at base angle, girts, sheeting angle and eave strut.

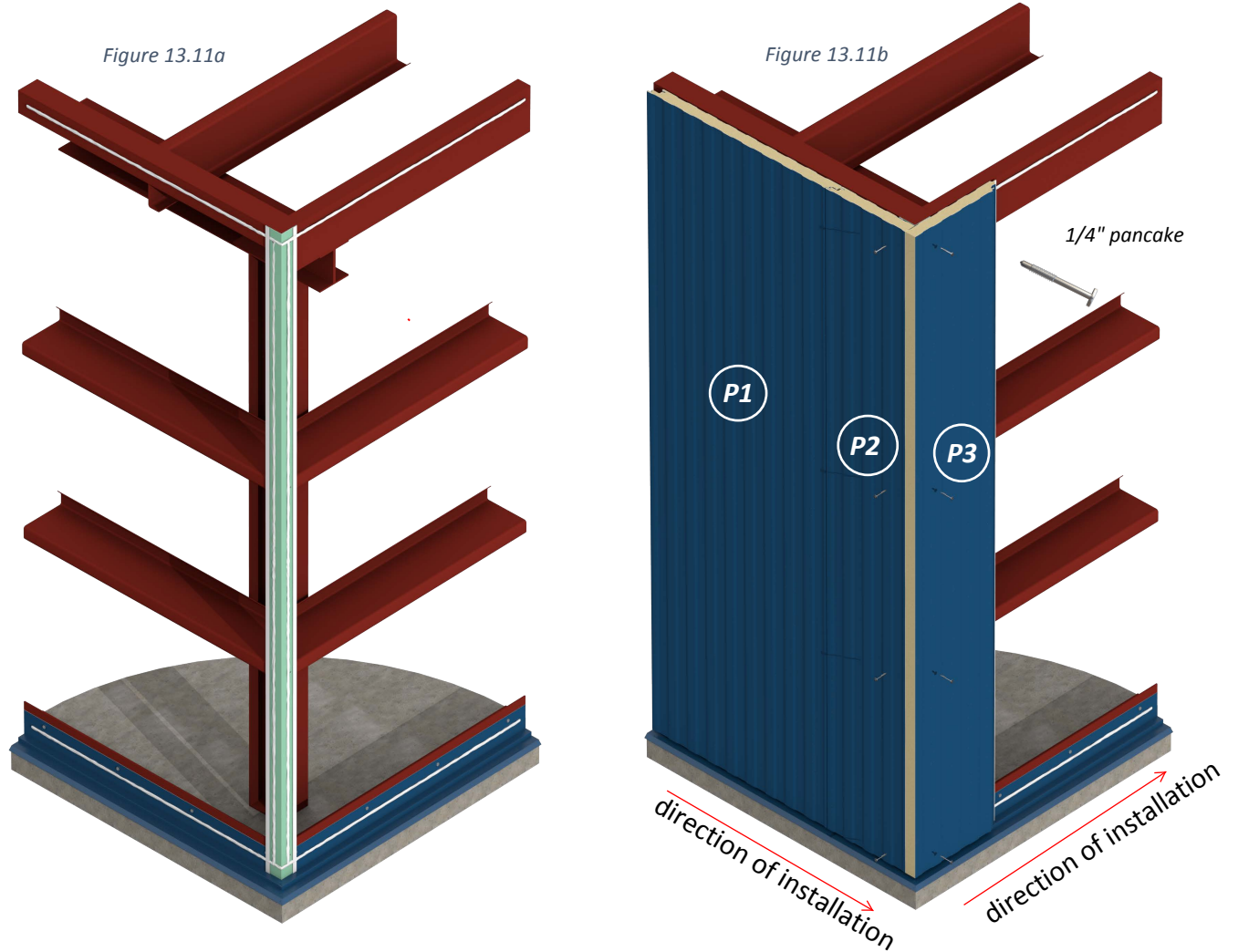

13.12 Apply expandable foam as shown in the figure below.

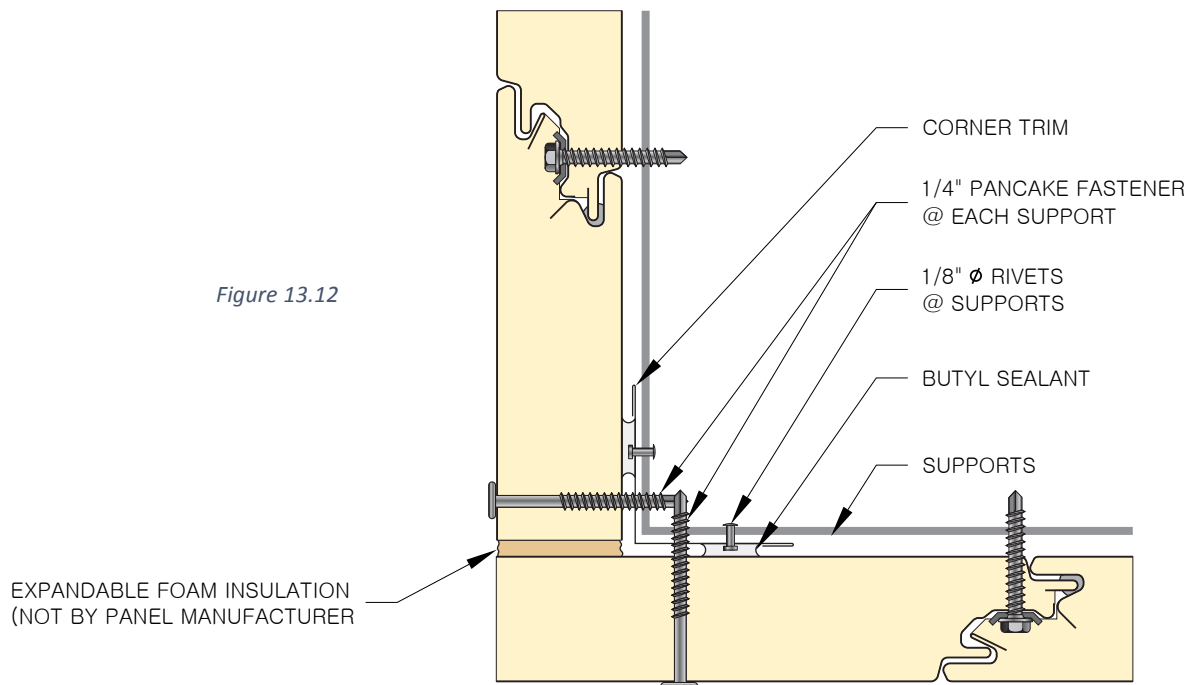

13. PANEL INSTALLATION - INSIDE CORNER

13.13 Cut leading edge of panel P2, trailing edge of panel P3 at inside corner. Attach cut edges of panels at corner with 1/4" pancake fasteners at base angle, girts, sheeting angle and eave strut.

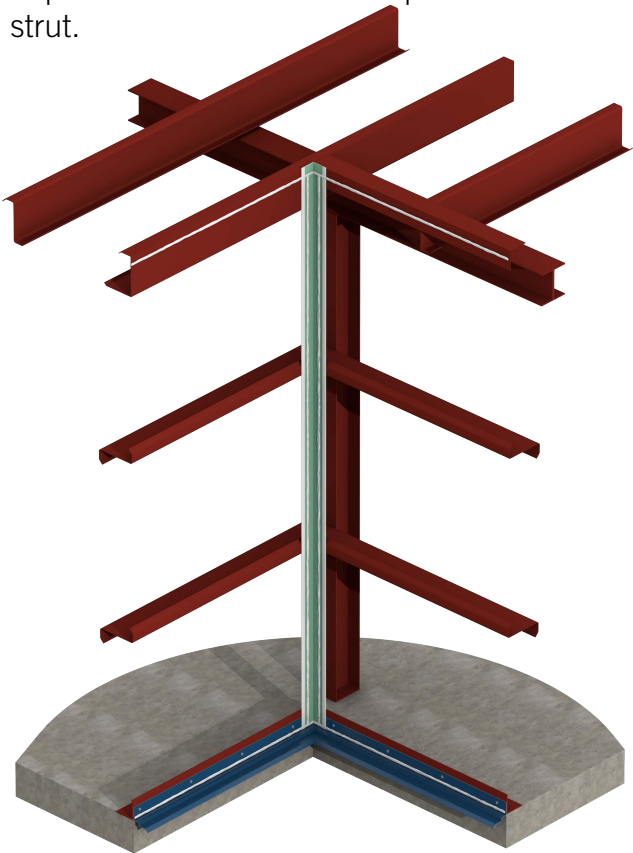

Figure 13.13a

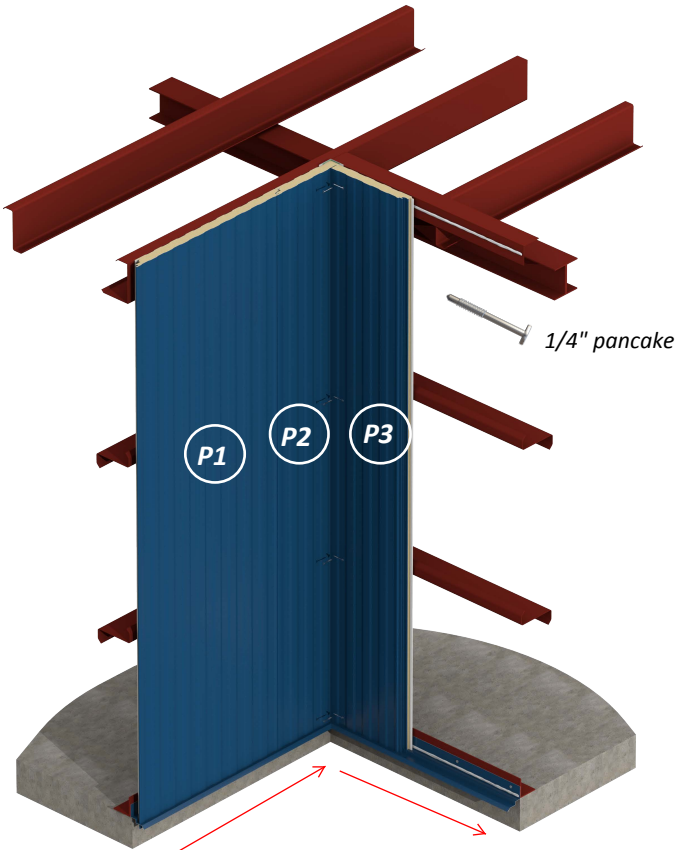

Figure 13.13b direction of installation

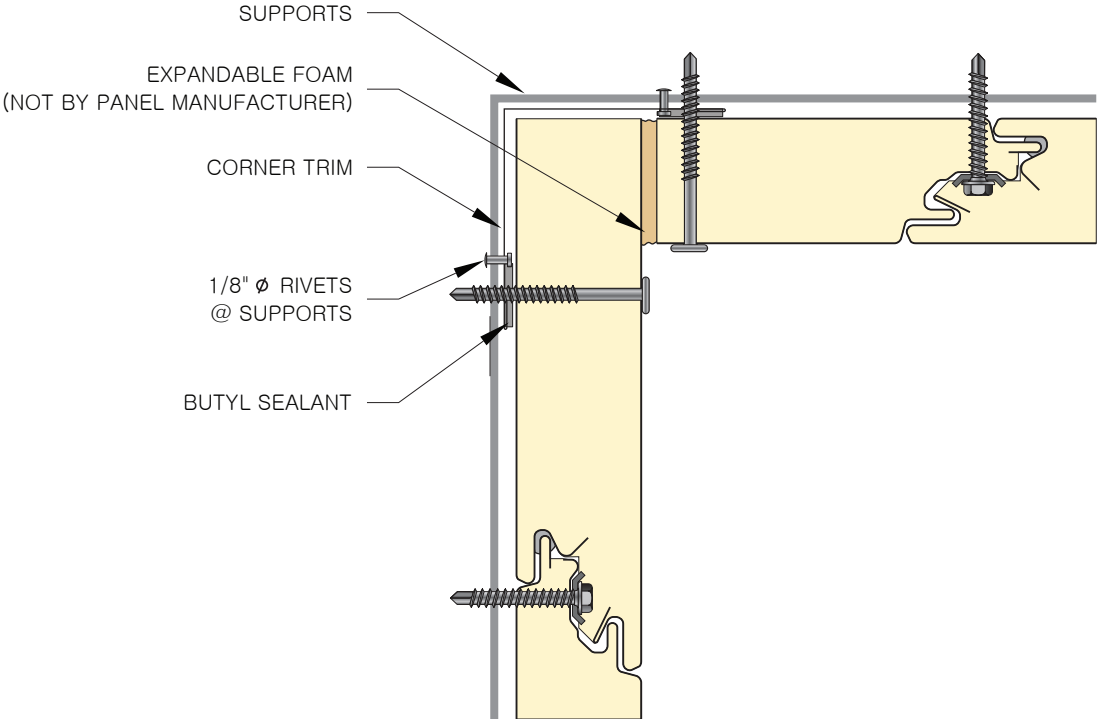

Figure 13.13c

13. PANEL INSTALLATION - ENDWALL ELEVATION

13.14 Install panels and cut in place to match roof slope. Apply marriage beads at top and bottom of EVERY panel.

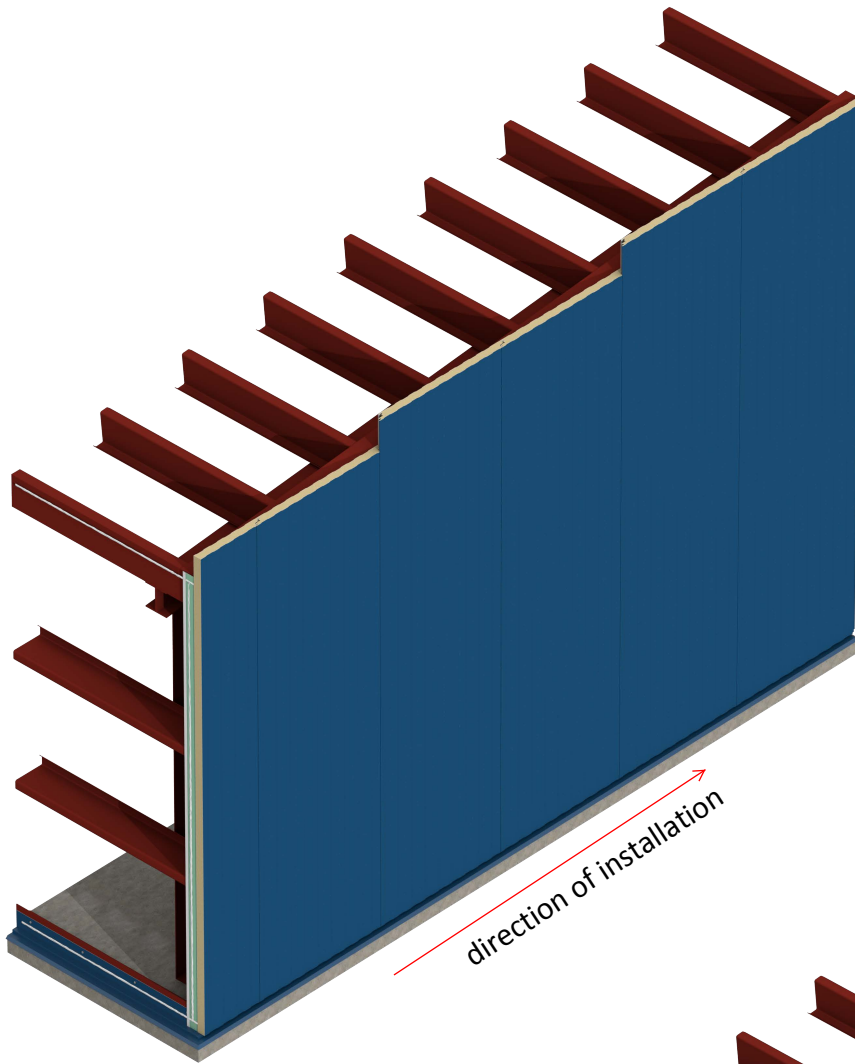

Figure 13.14a

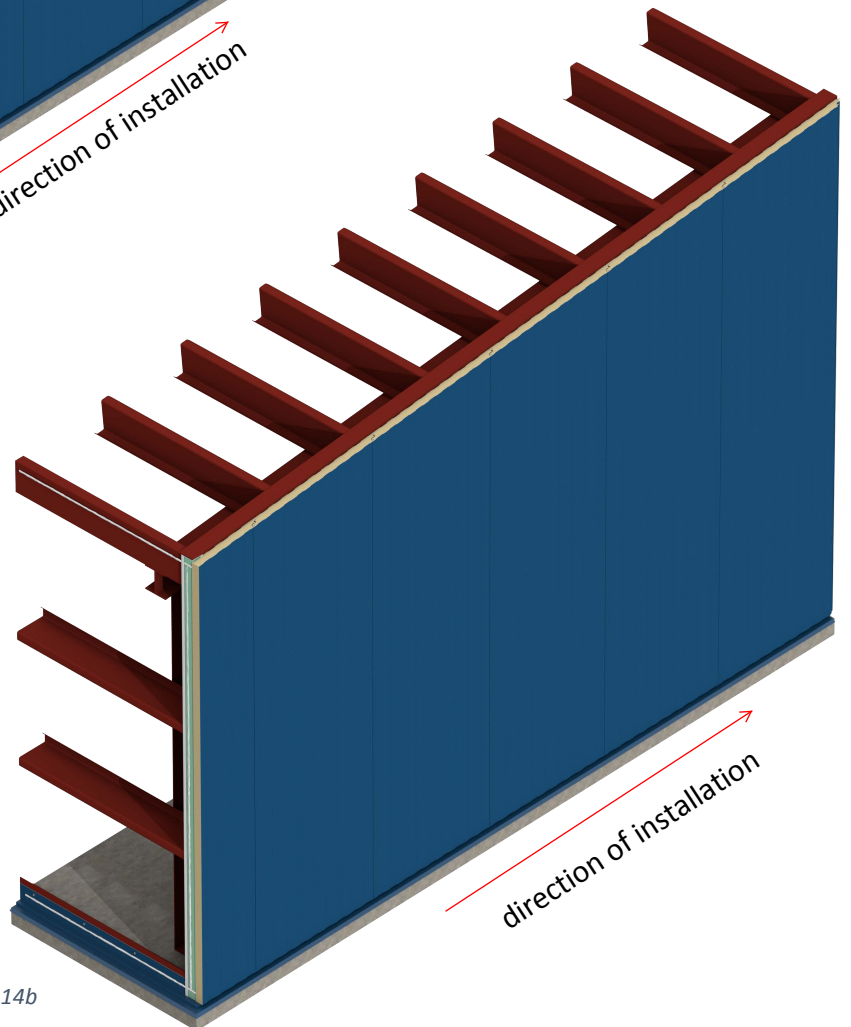

Figure 13.14b

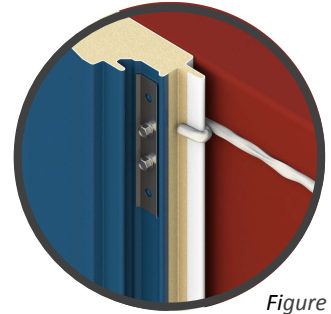

Figure 13.14c

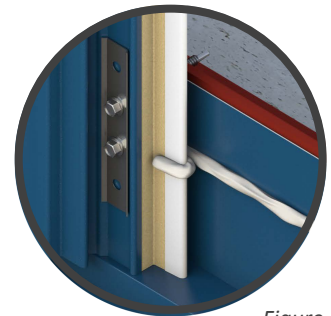

Figure 13.14d

13. PANEL INSTALLATION - FRAMED OPENINGS

13.15 Apply urethane sealant on head trim and at each end to create end dams.

13.16 Apply urethane or non-skinning butyl sealant on jamb and sill areas.

WARNING: END DAMS ARE REQUIRED TO PREVENT WINDOW LEAKS!

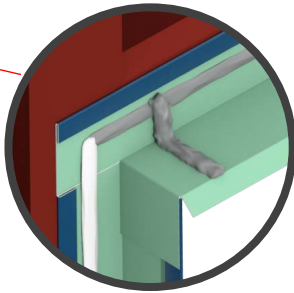

Figure 13.15

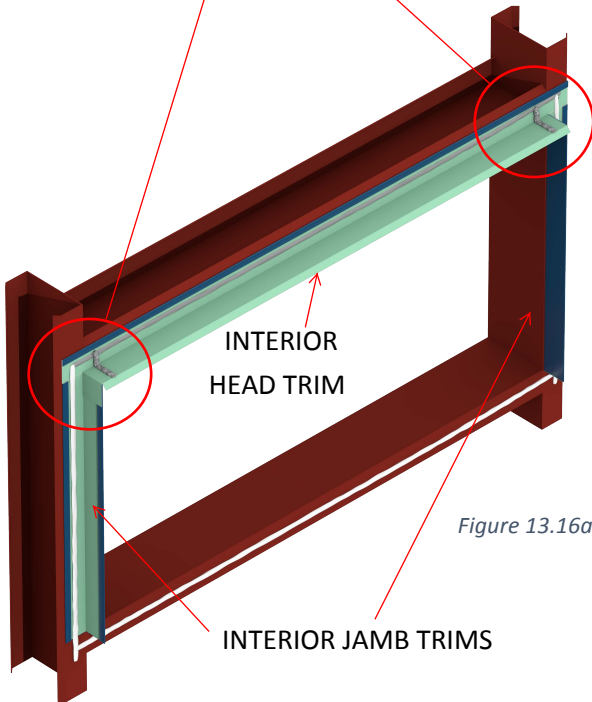

Figure 13.16a

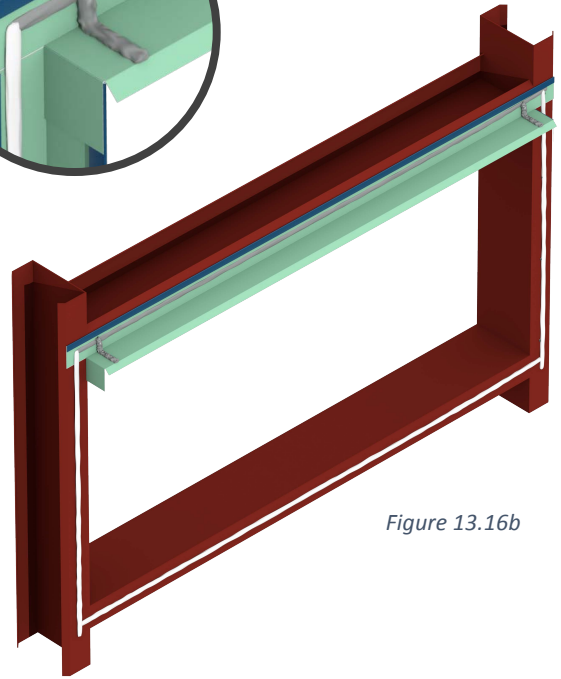

Figure 13.16b

STANDARD TWO PIECE WINDOW JAMB
VERIFY PER INSTALLATION DRAWINGS.

OPTIONAL ONE PIECE WINDOW JAMB
VERIFY PER INSTALLATION DRAWINGS.

STANDARD TWO PIECE DOOR JAMB
VERIFY PER INSTALLATION DRAWINGS.

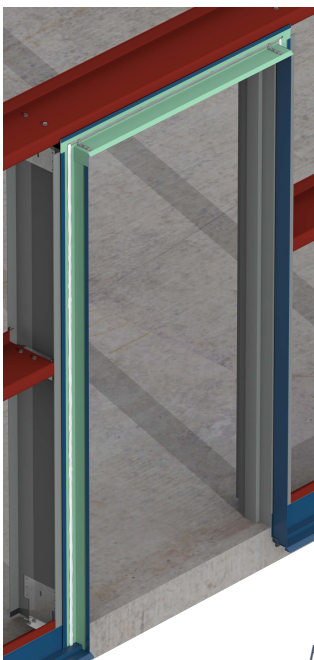

Figure 13.16c

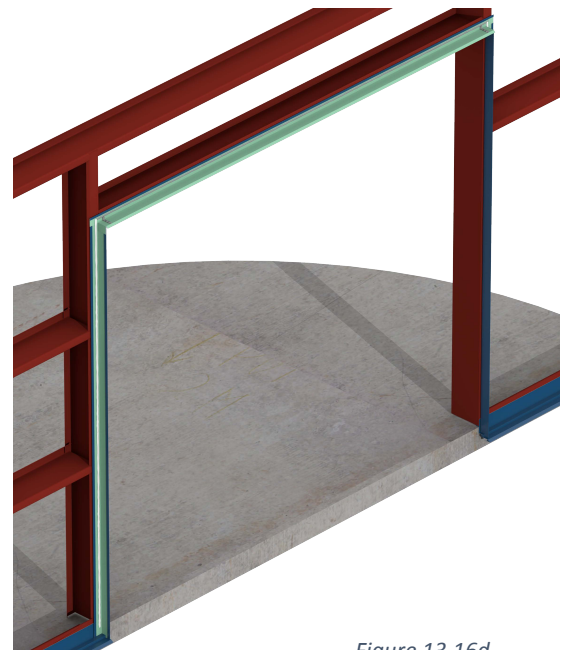

Figure 13.16d

13. PANEL INSTALLATION - FRAMED OPENINGS

13.16 Cut panels at framed openings per Chapter 7 PANEL CUTTING - Framed Openings.

13.17 Lift panels and secure to perimeter of framed opening using 1/4" pancake fasteners (if required by installation drawings).

STANDARD TWO PIECE WINDOW JAMB
VERIFY PER INSTALLATION DRAWINGS.

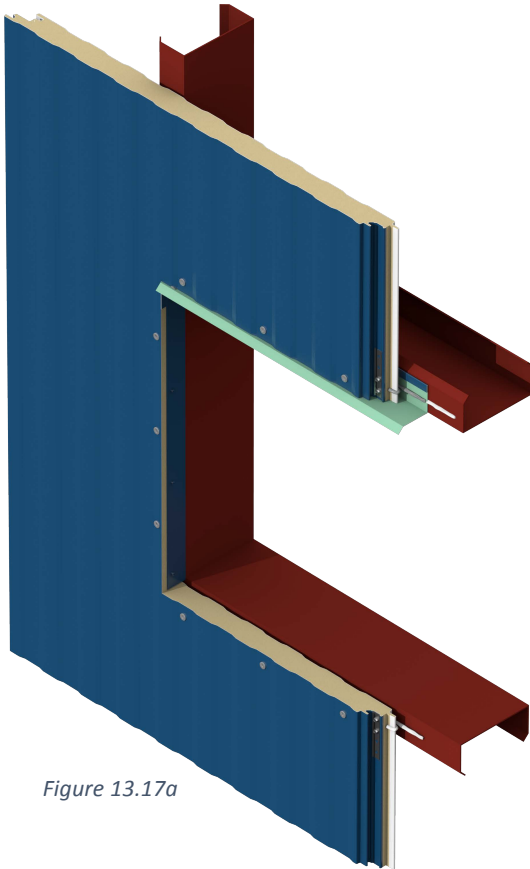

Figure 13.17a

OPTIONAL ONE PIECE WINDOW JAMB
VERIFY PER INSTALLATION DRAWINGS.

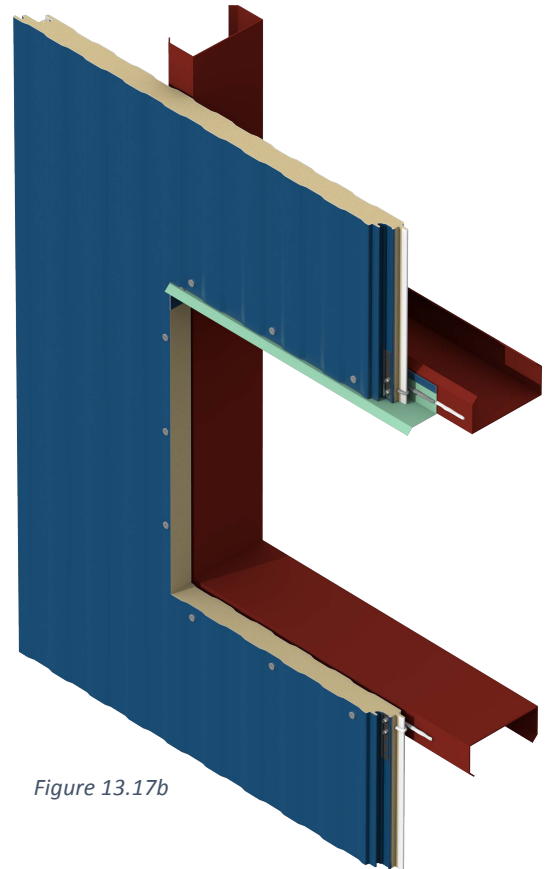

Figure 13.17b

13.18 Apply marriage bead of non-skinning butyl sealant at all head and sill panels.

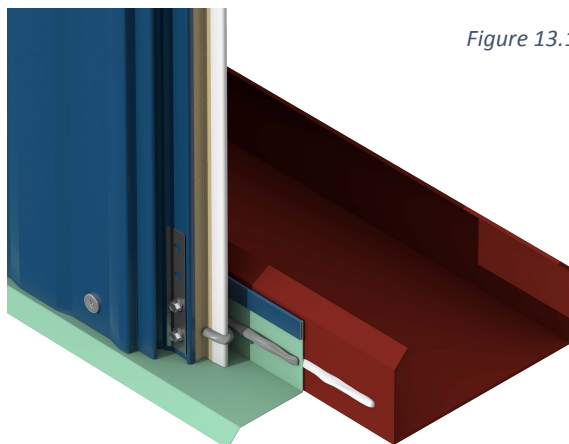

Figure 13.18a

MARRIAGE BEAD AT HEAD

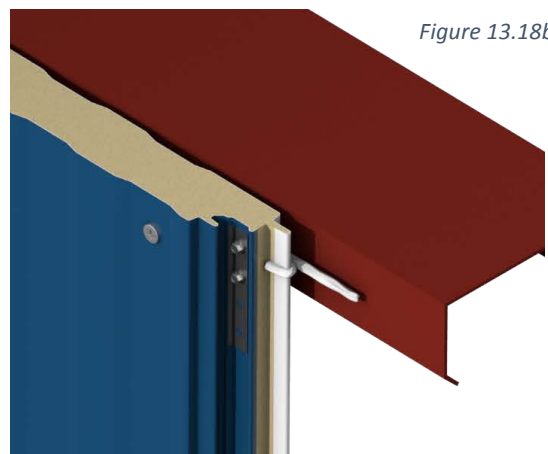

Figure 13.18b

MARRIAGE BEAD AT SILL

14. EXTERIOR TRIM INSTALLATION - FRAMED OPENINGS

14.1 Apply butyl tape at sill and jambs.

STANDARD TWO PIECE WINDOW JAMB

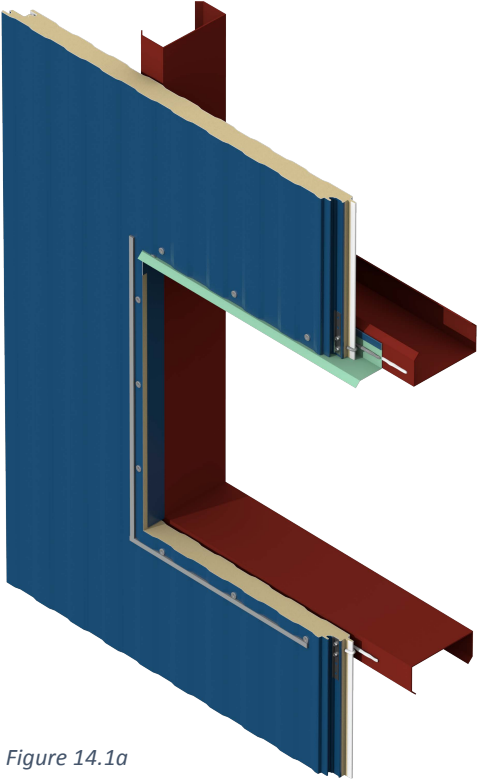

Figure 14.1a

OPTIONAL ONE PIECE WINDOW JAMB

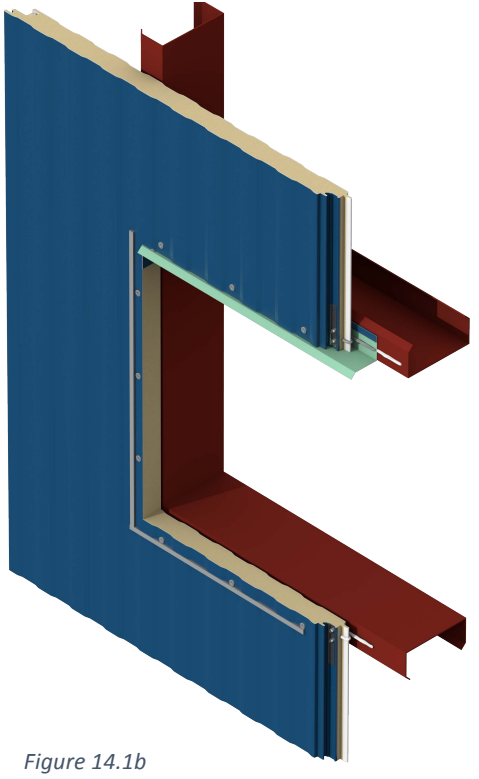

Figure 14.1b

14.2 Install one piece sill trim with tabs bent up using 1/8" stainless steel painted pop rivets at 8" on center.

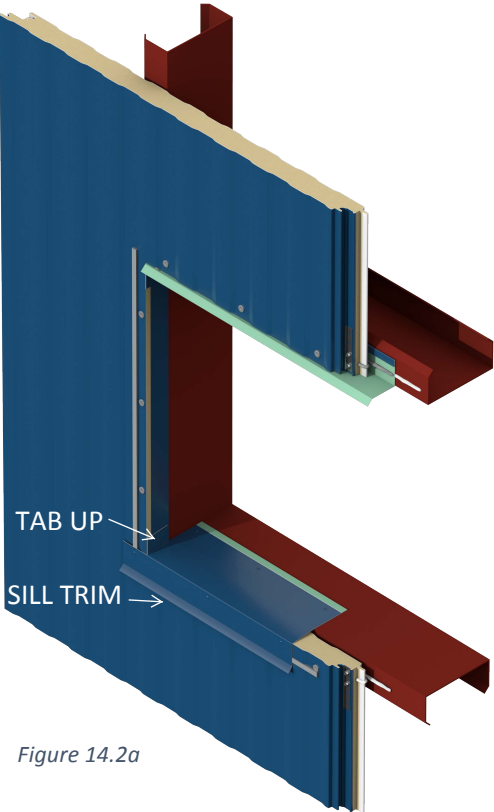

Figure 14.2a

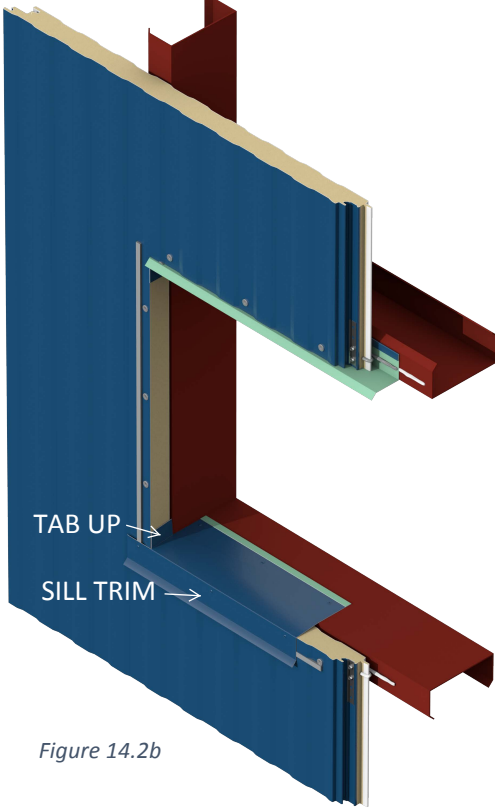
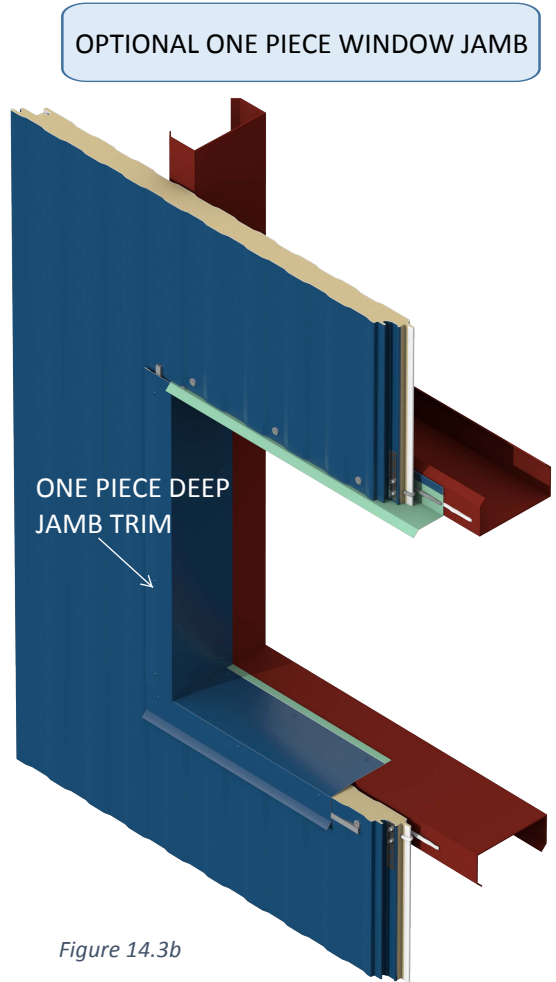
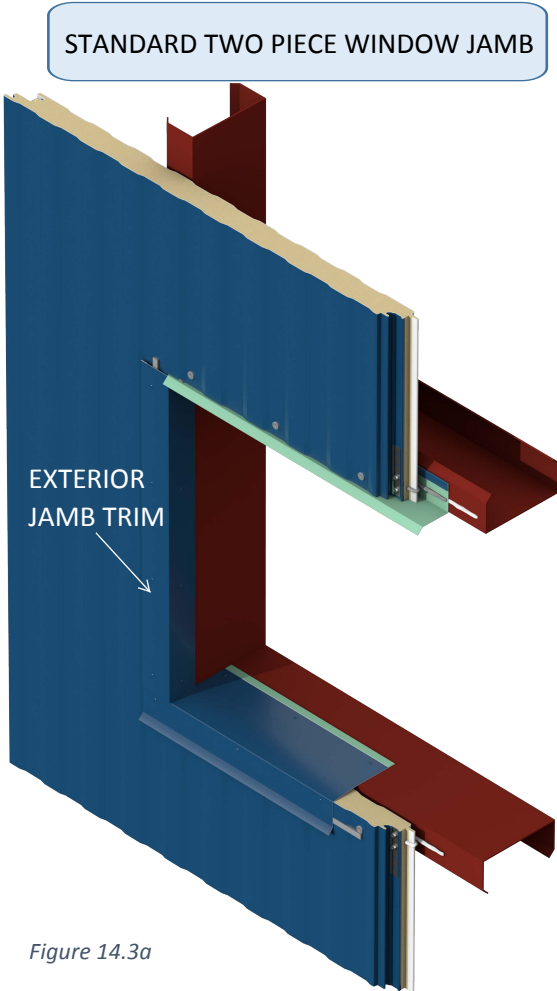

Figure 14.2b

14. EXTERIOR TRIM INSTALLATION - FRAMED OPENINGS

14.3 Install exterior jamb trims using 1/8" stainless steel painted pop rivets at 8" on center.



14.4 Apply urethane sealant at lap and attach exterior head trim using 1/8" stainless steel painted pop rivets at 8" on center.

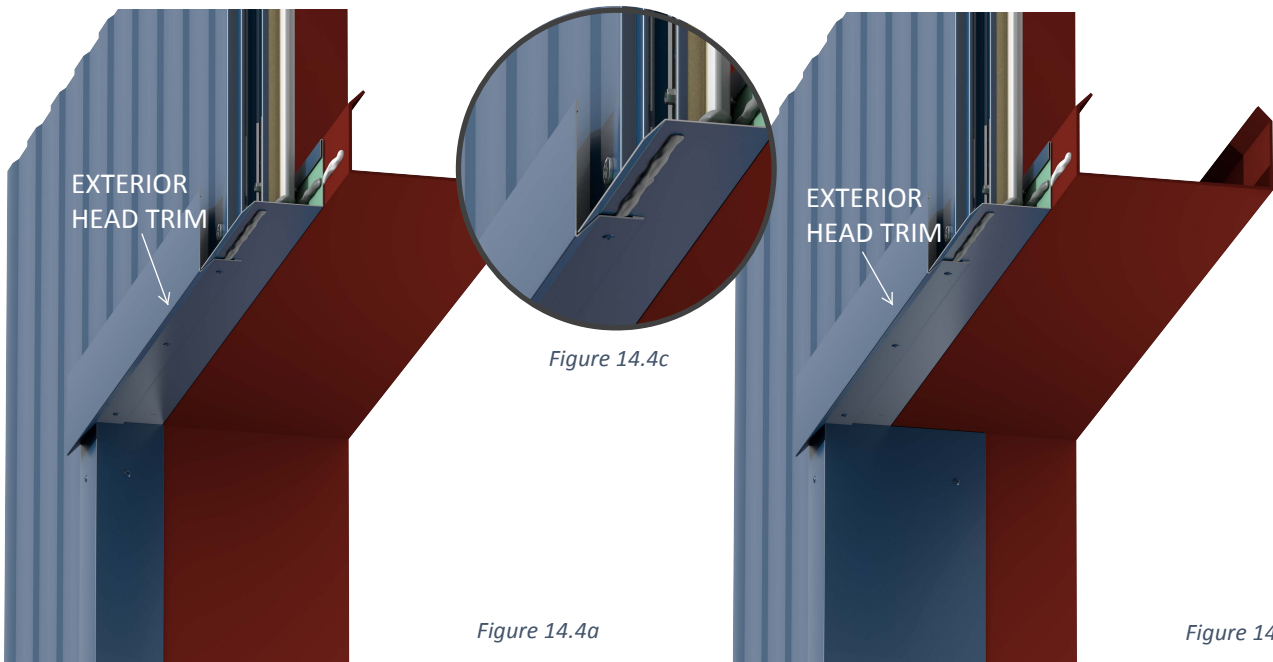

14. EXTERIOR TRIM INSTALLATION - FRAMED OPENINGS

COMPLETED WINDOW TRIM WITH TWO PIECE JAMBS

Figure 14.4d

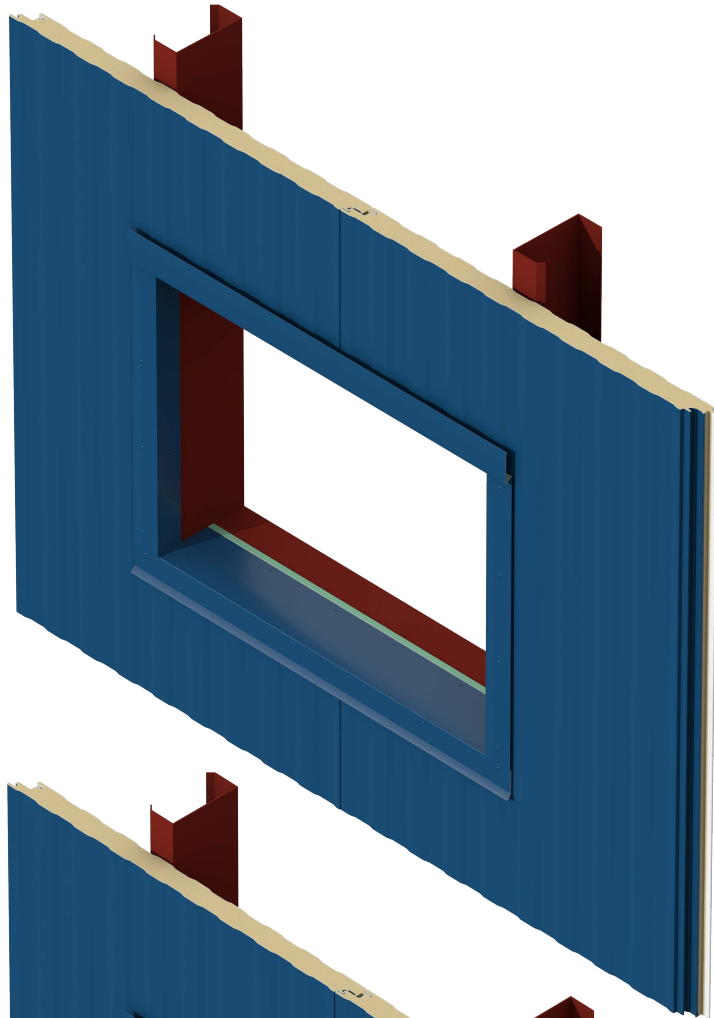

COMPLETED WINDOW TRIM WITH ONE PIECE DEEP JAMBS

Figure 14.4e

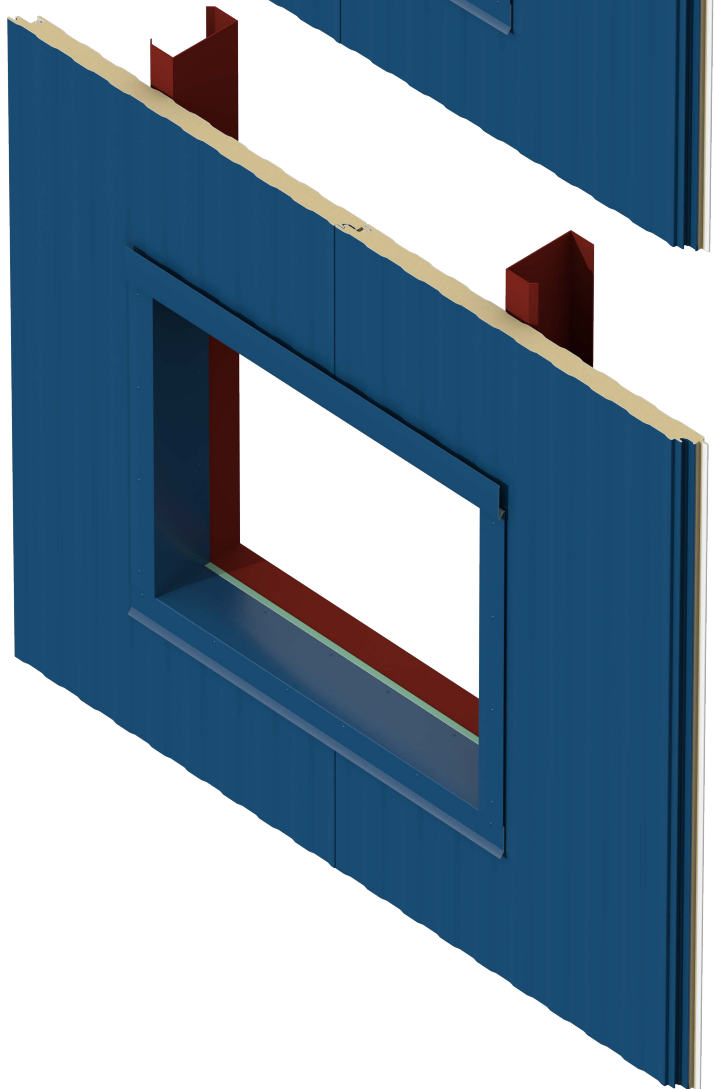

14. EXTERIOR TRIM INSTALLATION - BASE

14.5 Install exterior base trims with 1/8" stainless steel painted pop rivets at 8" on center.

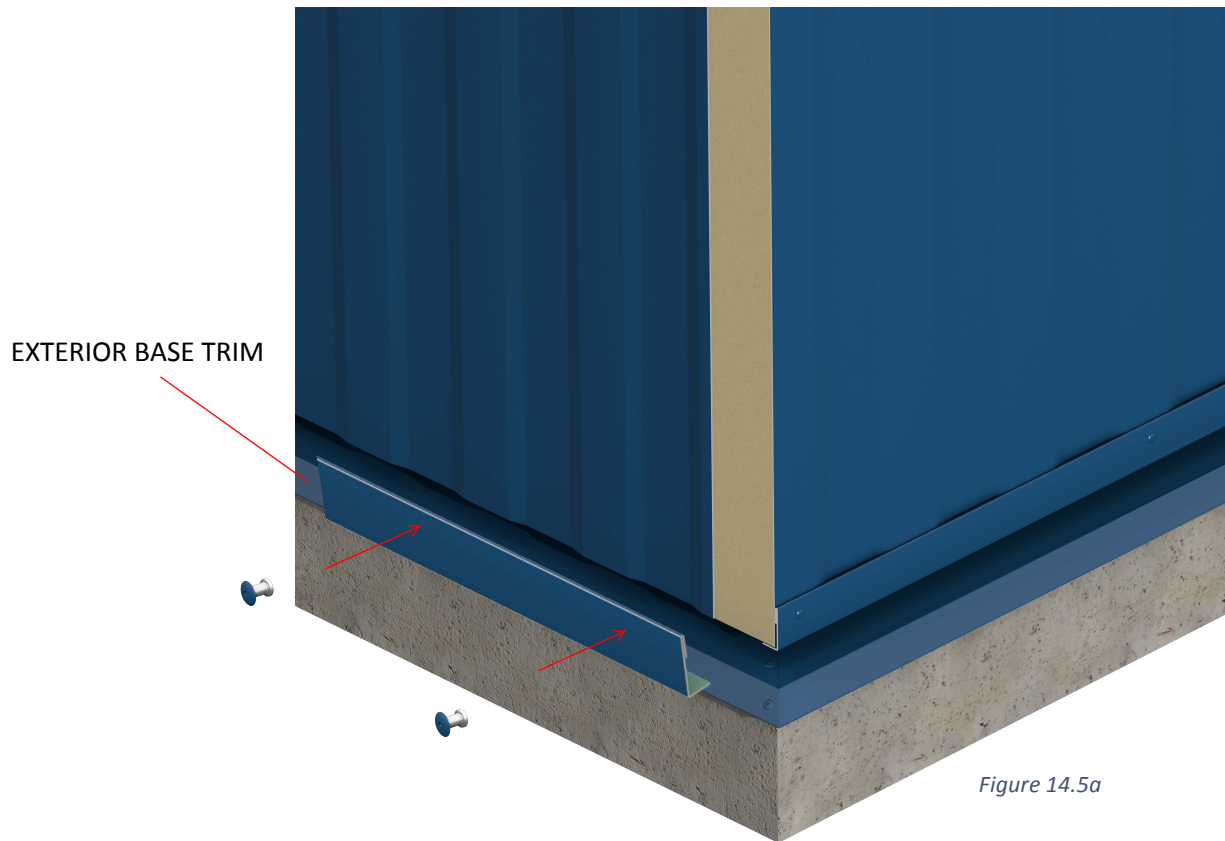

14. EXTERIOR TRIM INSTALLATION - CORNERS

14.6 Apply butyl tape to interior side of corner trims (if required per installation drawings) and install with 1/8" stainless steel painted pop rivets at 8" on center.

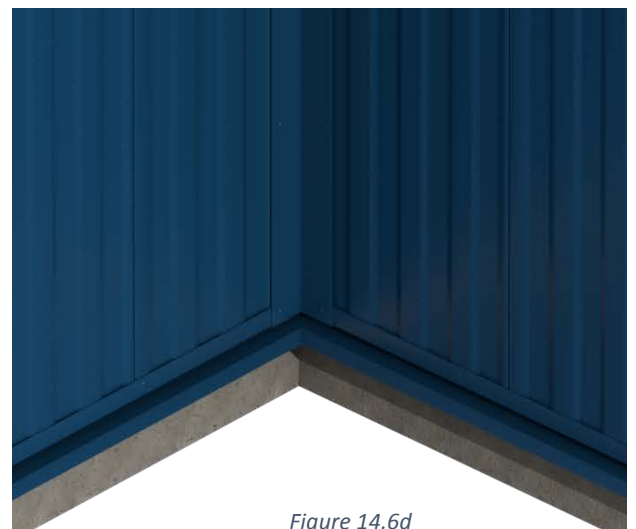
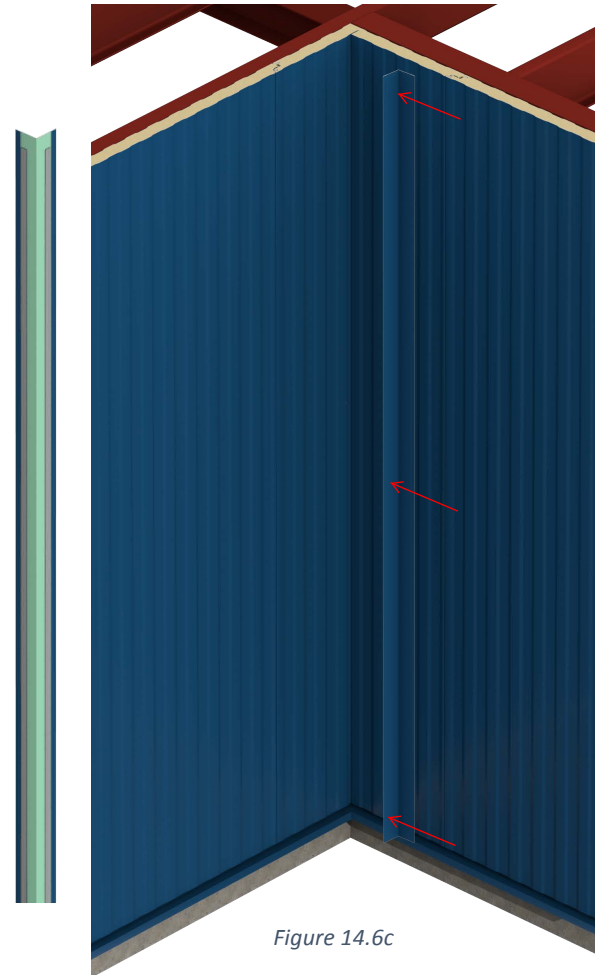
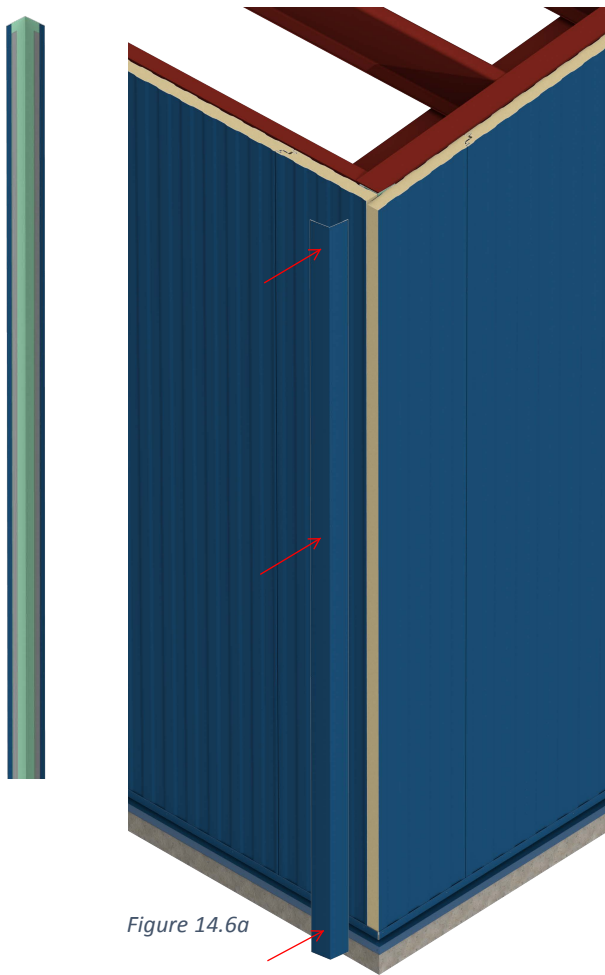

15. GENERAL DETAILS

WARNING: THIS CHAPTER CONTAINS *GENERAL DETAILS ONLY* - REFER TO PROJECT INSTALLATION (SHOP) DRAWINGS FOR PROJECT SPECIFIC DETAILS!

14 GA. PANEL CLIP
W/ 1/4" HWH FASTENERS
@ EACH WALL SUPPORT

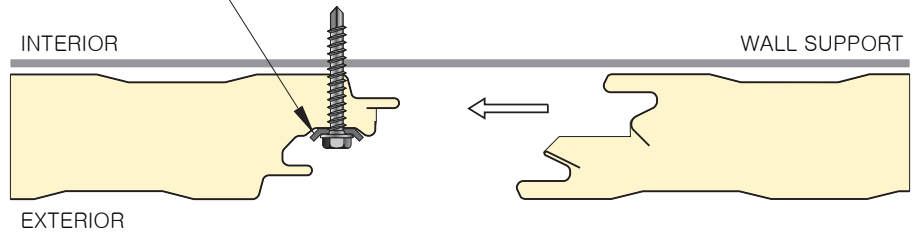

CLIP AND FASTENER ASSEMBLY

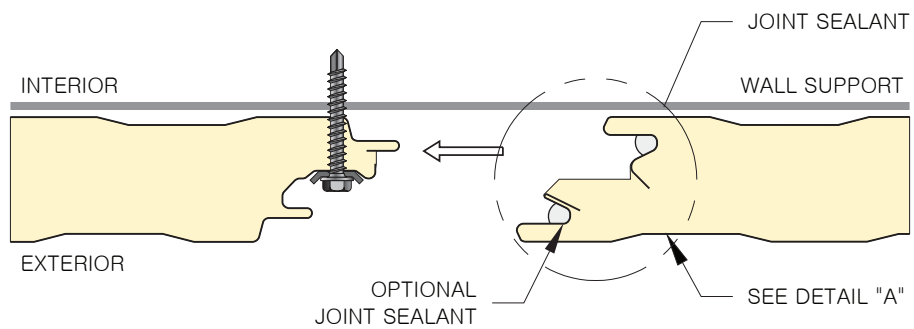

JOINT SEALANT APPLICATION

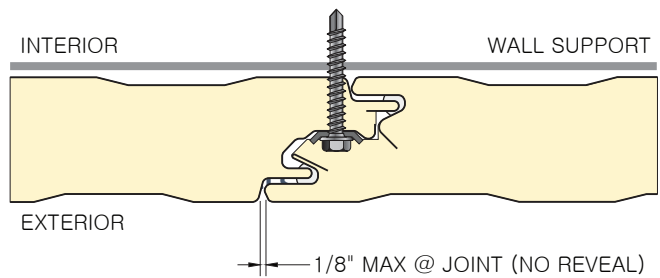
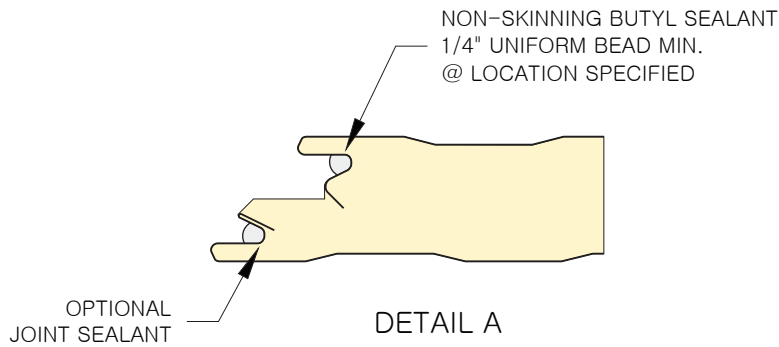

**CI-CF-JT-03
PANEL JOINT DETAILS**

15. GENERAL DETAILS

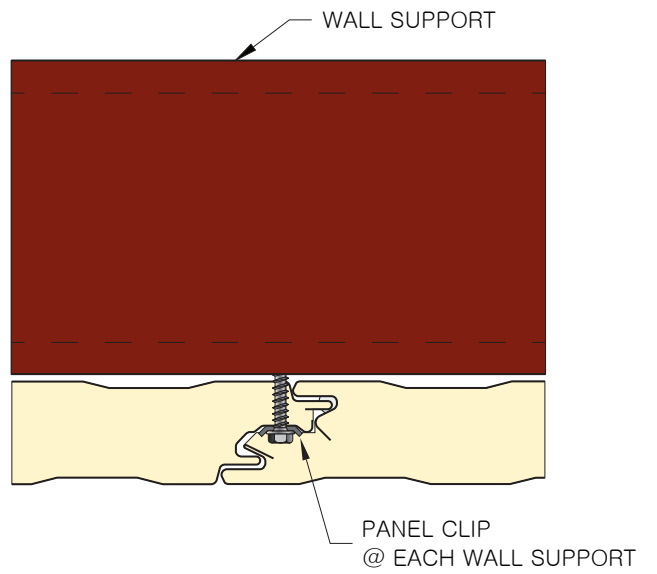
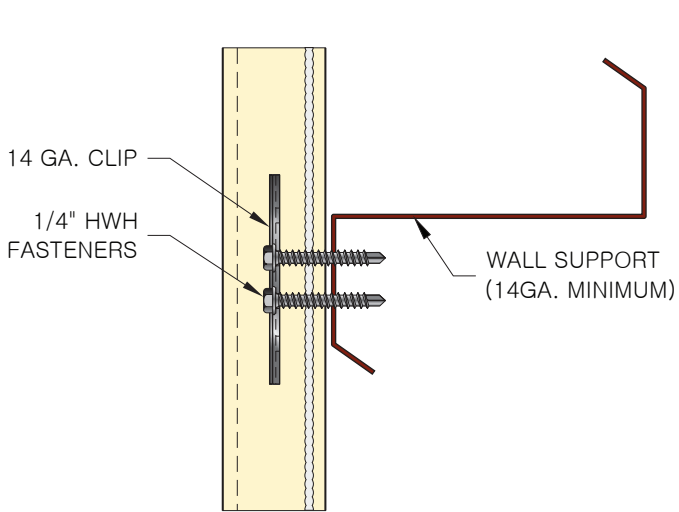

CI-CF-FSTN-01A
ATTACHMENT SIDEJOINT - PRE-ENGINEERED

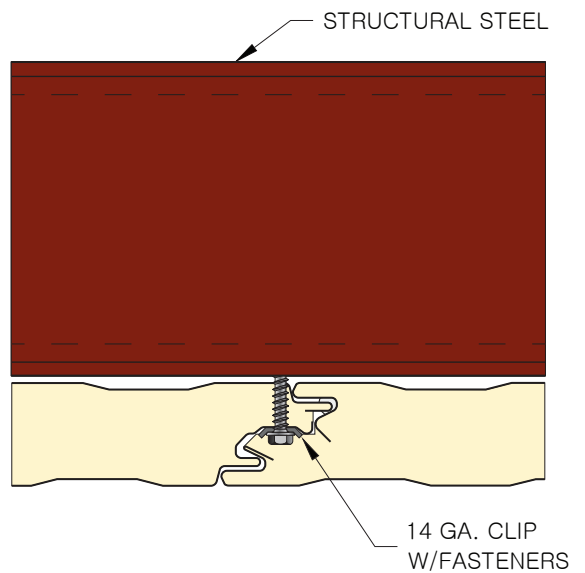
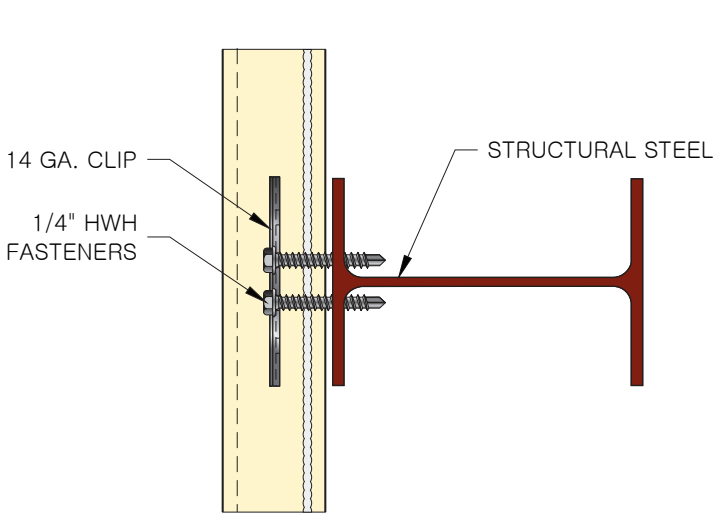

CI-CF-FSTN-01B
ATTACHMENT SIDEJOINT - STRUCTURAL

15. GENERAL DETAILS

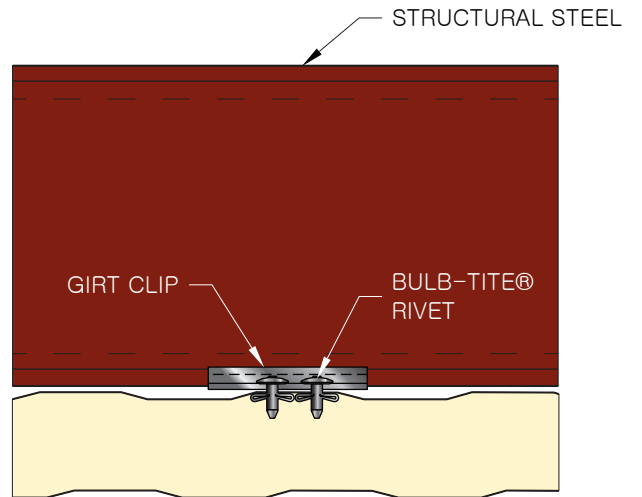
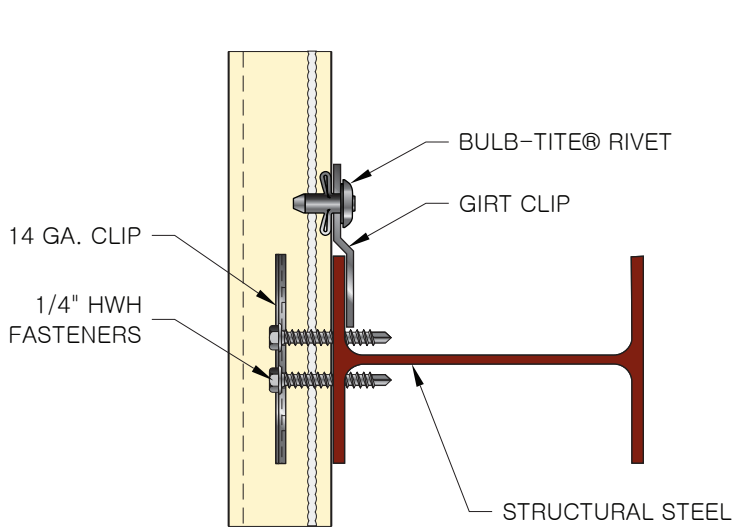

CI-CF-FSTN-01C
ATTACHMENT BACK-FASTENED W/GIRT CLIPS

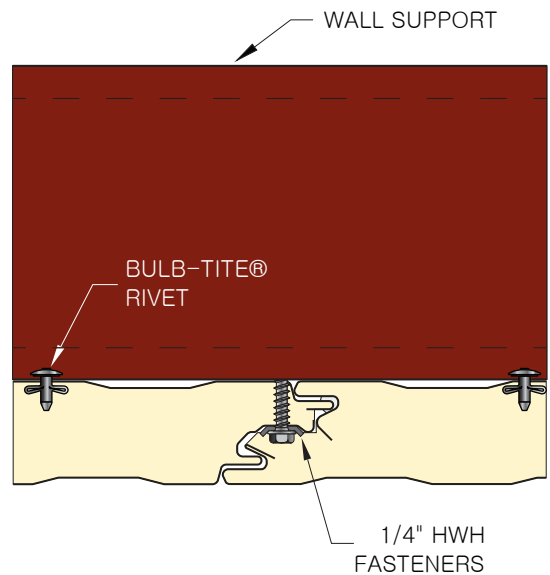
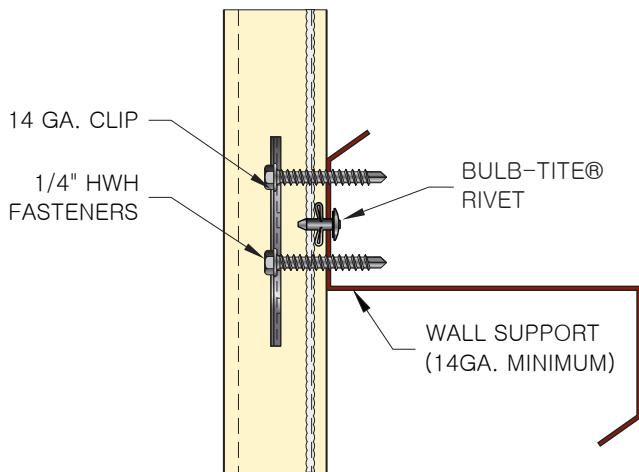

CI-CF-FSTN-01D
ATTACHMENT BACK-FASTENED W/RIVETS

15. GENERAL DETAILS

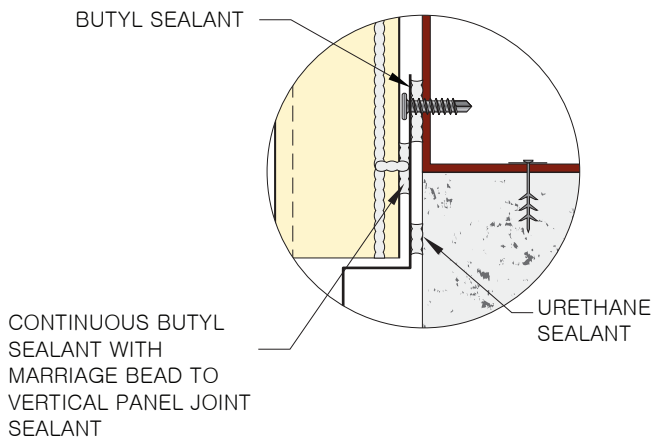
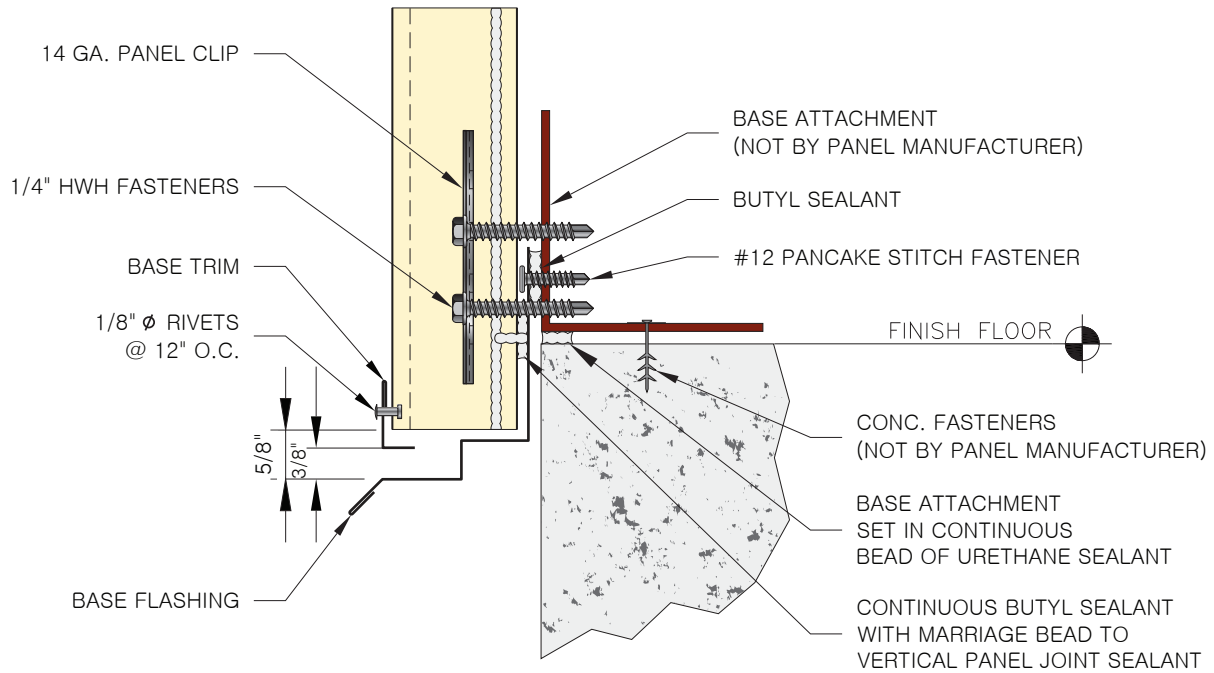

ALTERNATE PLACEMENT OF SEALANT

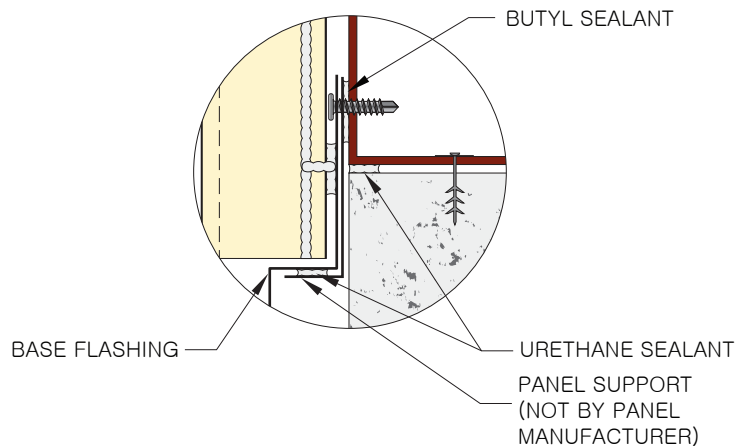

OPTIONAL PANEL SUPPORT

CI-CF-BE-06 BASE - OVERHANG W/DRIP TRIM

15. GENERAL DETAILS

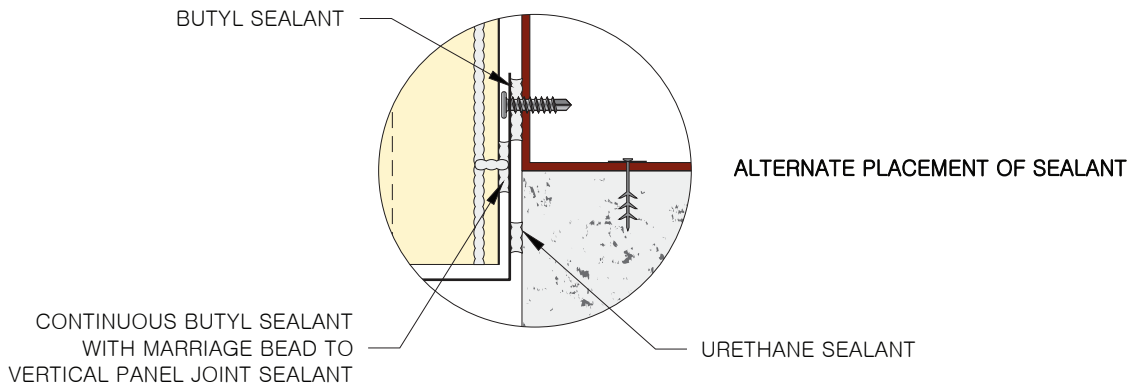
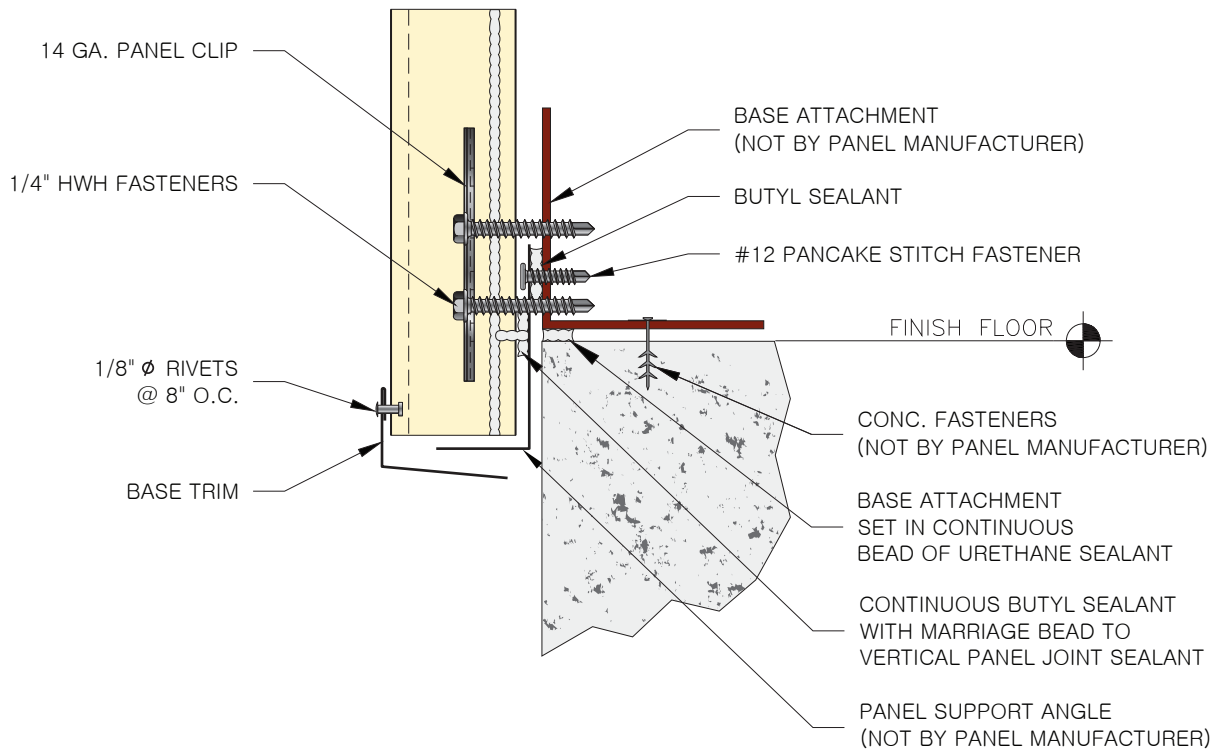

CI-CF-BE-07
BASE - OVERHANG W/EDGE TRIM

15. GENERAL DETAILS

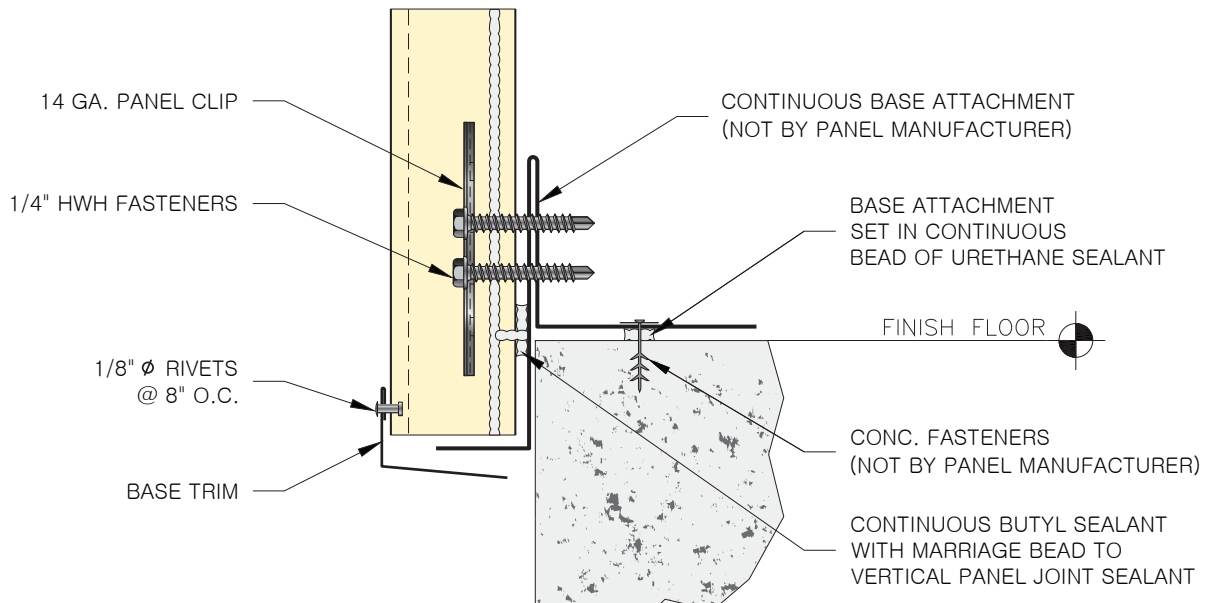

CI-CF-BE-08
BASE - OVERHANG W/BASE SUPPORT

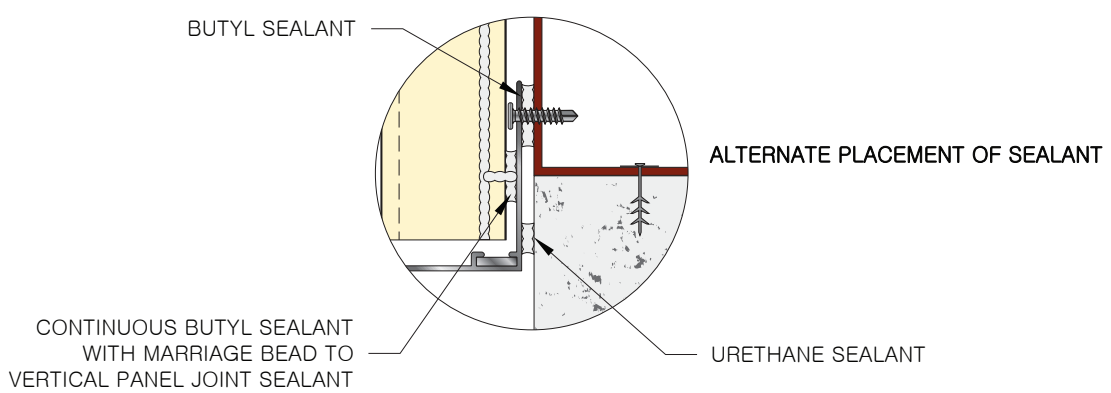
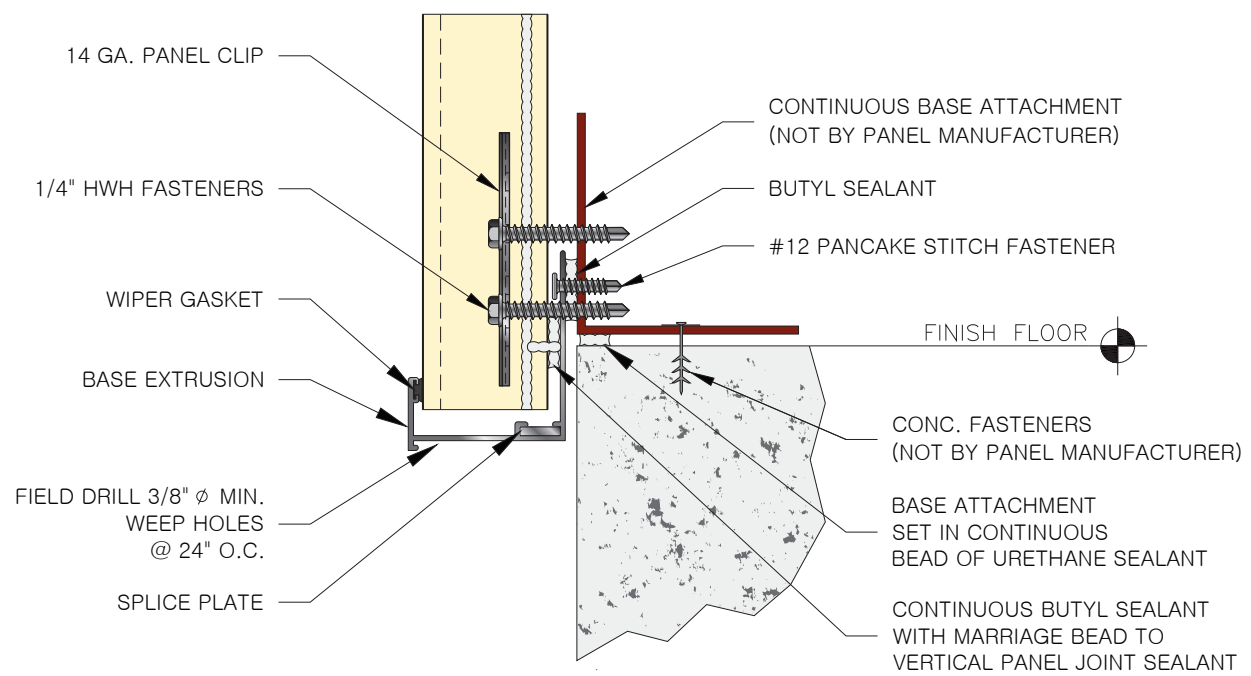

CI-CF-EB-02
BASE - OVERHANG W/EXTRUSION

15. GENERAL DETAILS

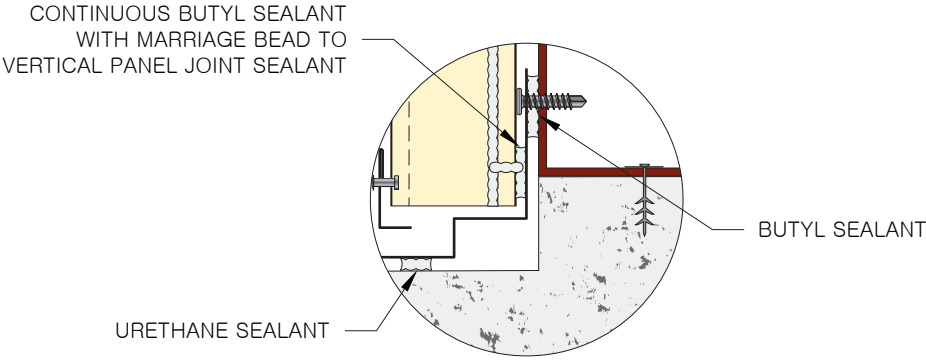
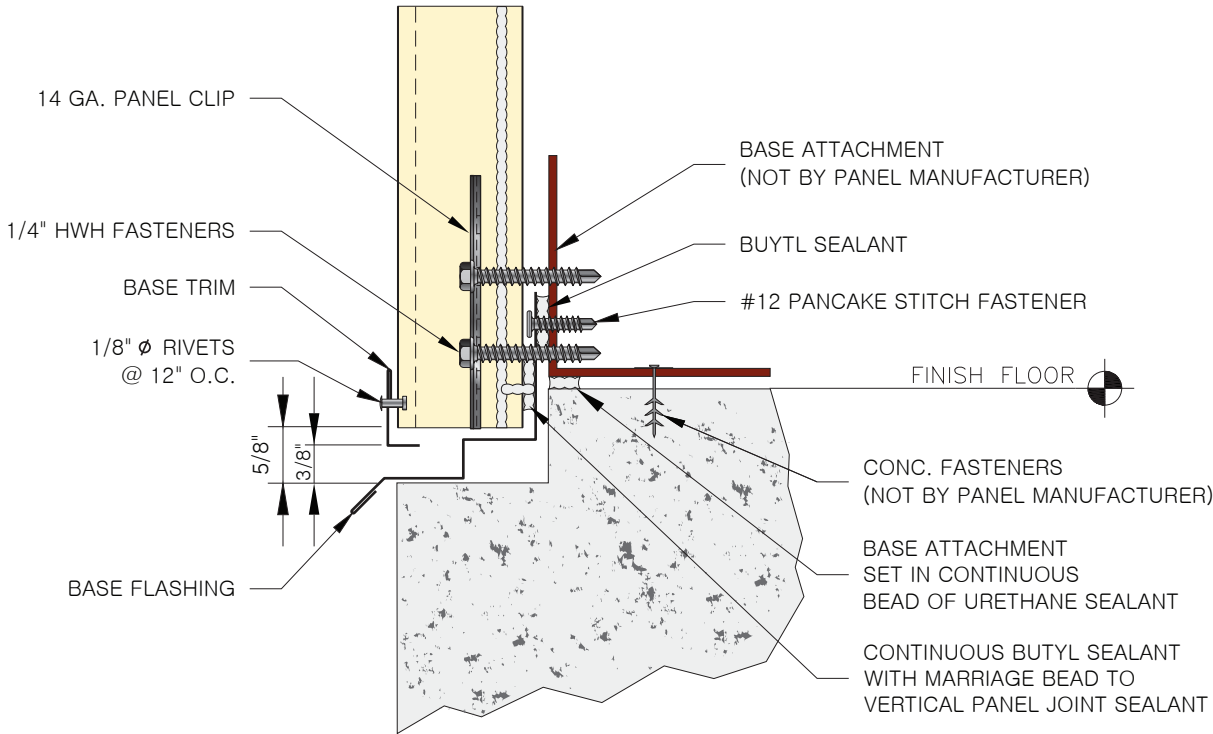

ALTERNATE PLACEMENT OF SEALANT

CI-CF-BE-02
BASE - OVERHANG W/NOTCHED SLAB

15. GENERAL DETAILS

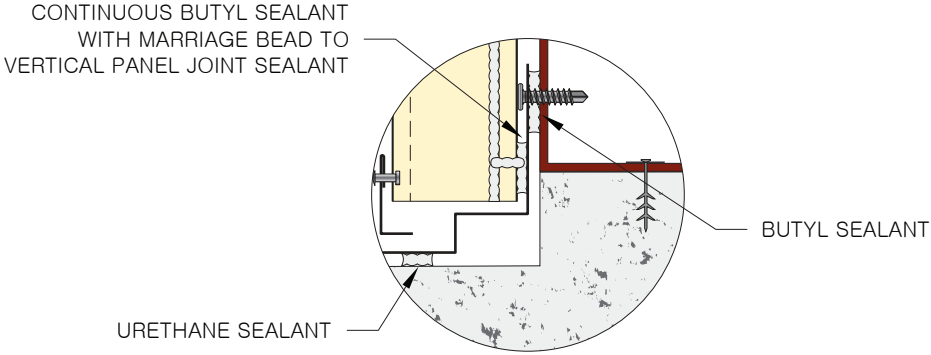
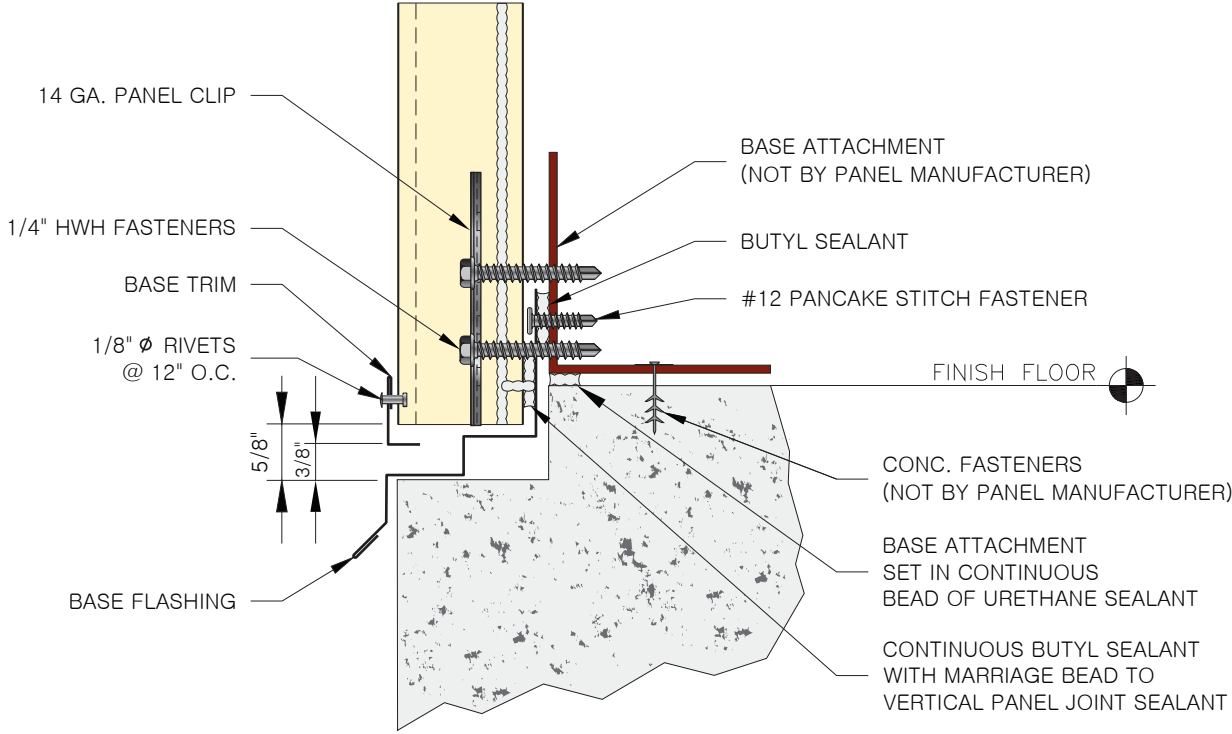

ALTERNATE PLACEMENT OF SEALANT

CI-CF-BE-04
BASE - OVERHANG W/NOTCHED SLAB ALT.

15. GENERAL DETAILS

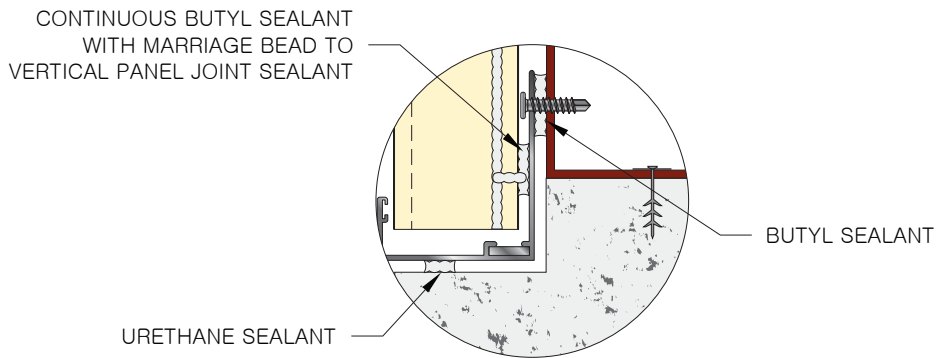
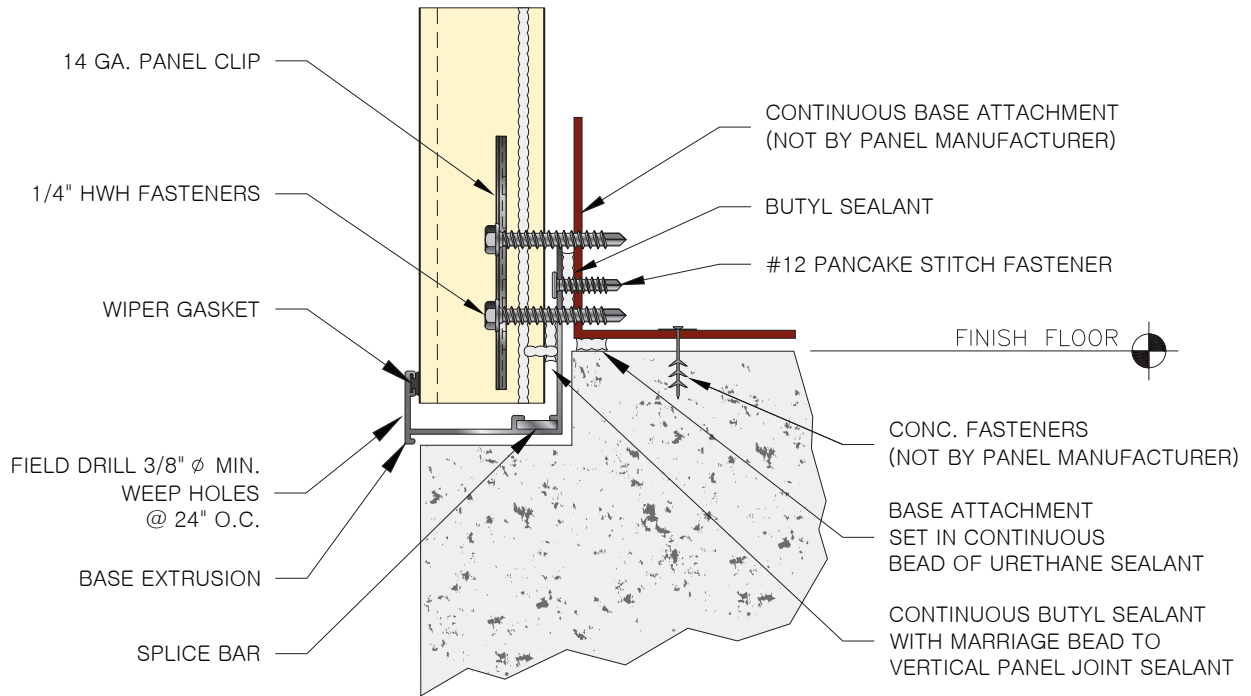

ALTERNATE PLACEMENT OF SEALANT

CI-CF-EB-01
BASE - OVERHANG W/NOTCHED SLAB, EXTRUSION

15. GENERAL DETAILS

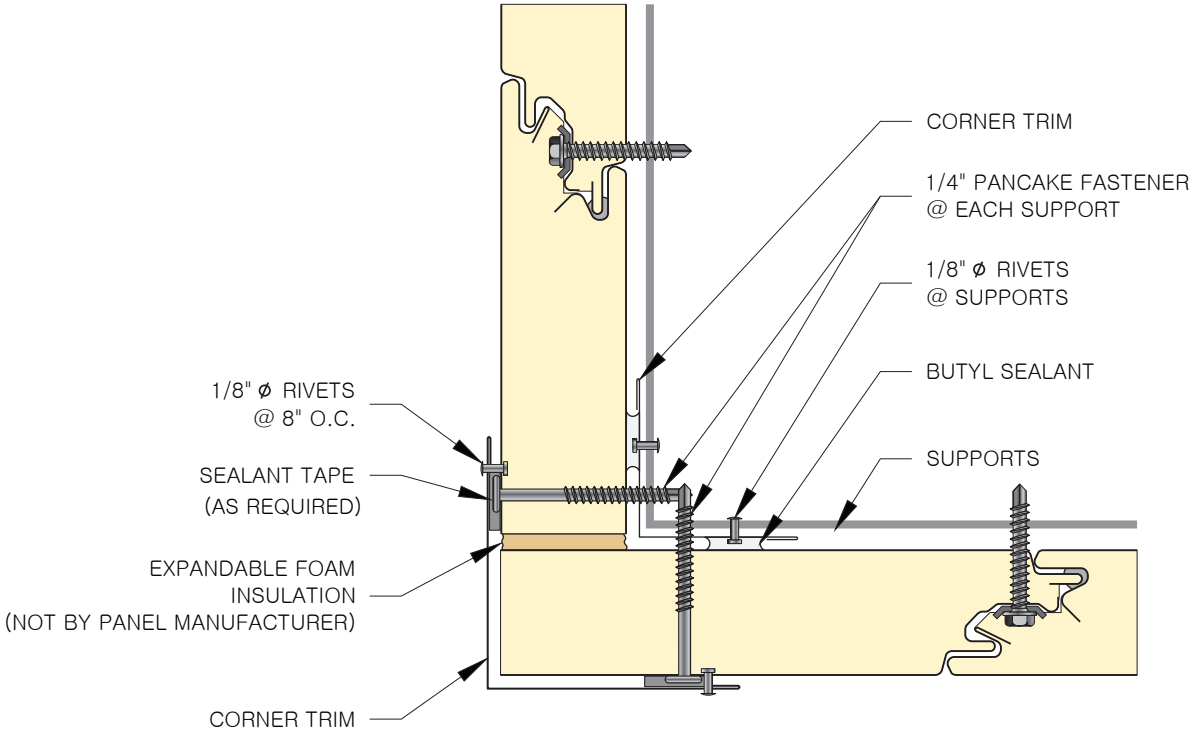

CI-CF-CE-01
OUTSIDE CORNER W/FLUSH TRIM

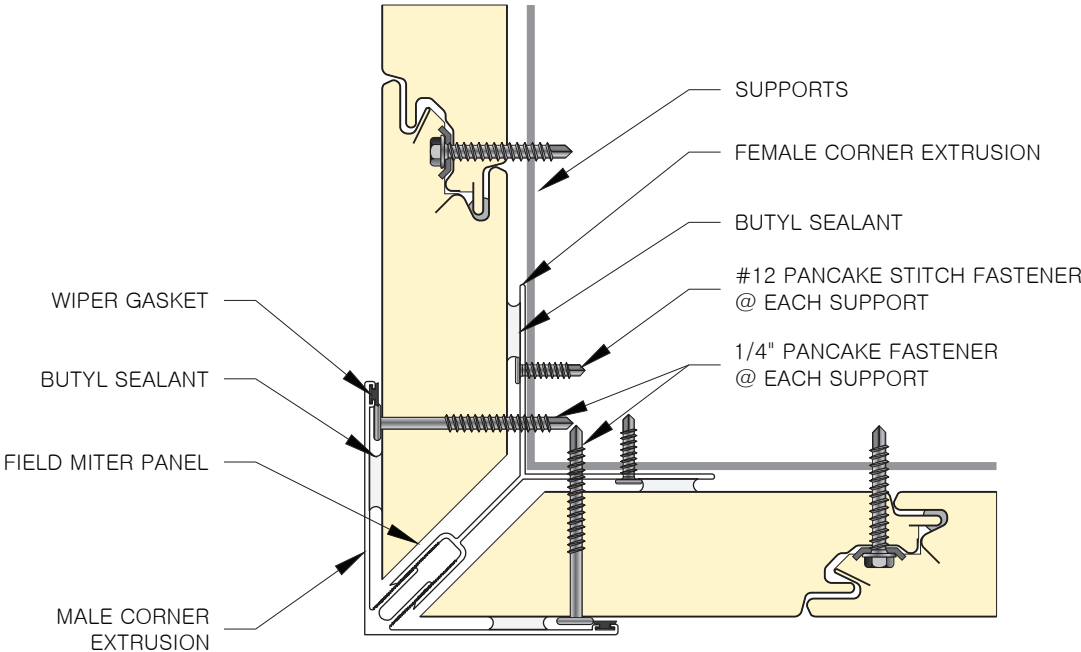

CI-CF-EC-01
OUTSIDE CORNER W/TWO PIECE EXTRUSION

15. GENERAL DETAILS

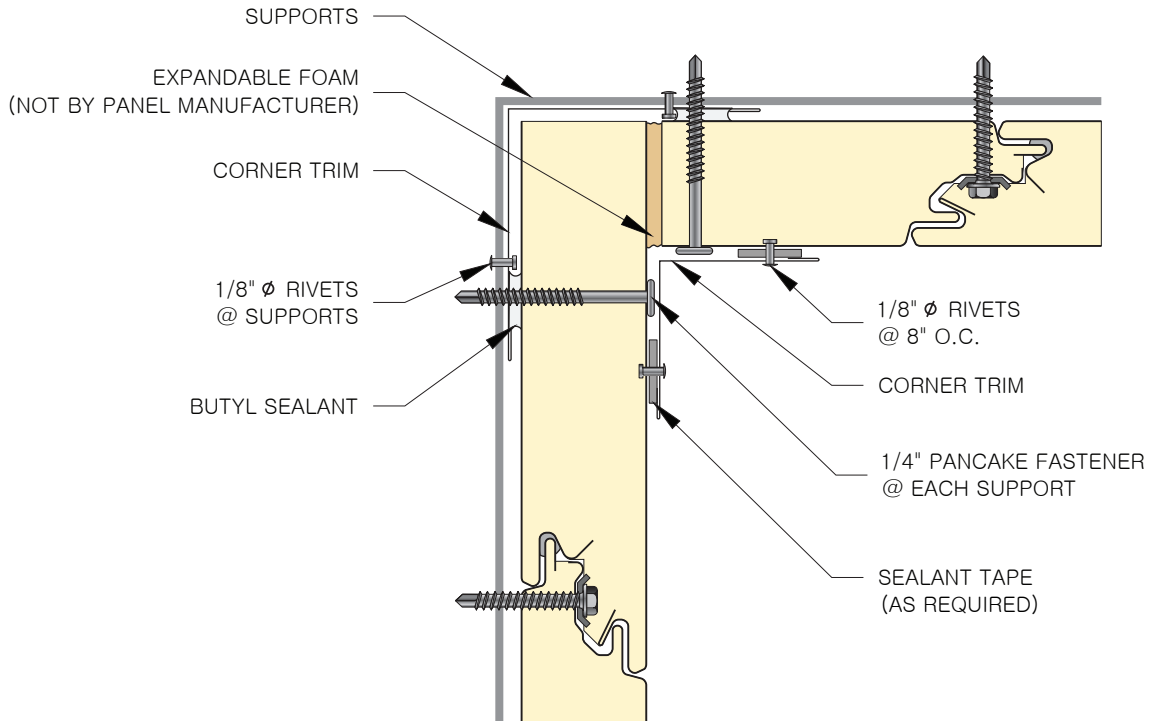

CI-CF-CE-03
INSIDE CORNER W/FLUSH TRIM

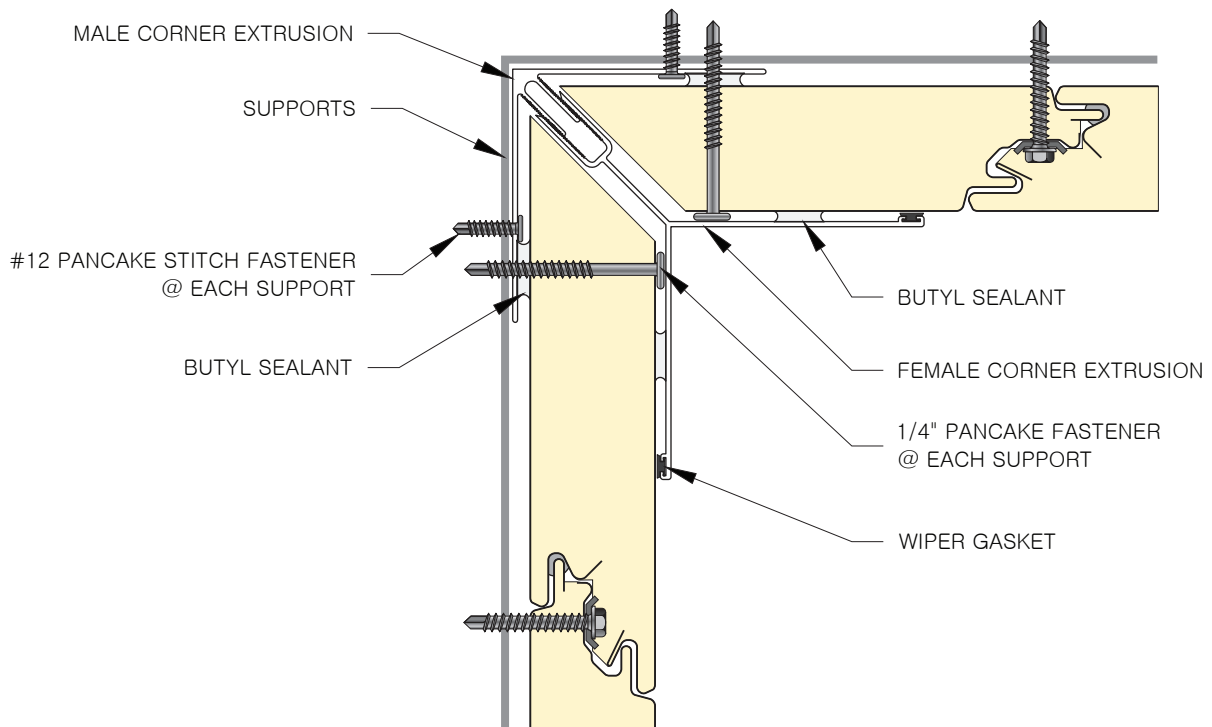

CI-CF-EC-02
INSIDE CORNER W/TWO PIECE EXTRUSION

15. GENERAL DETAILS

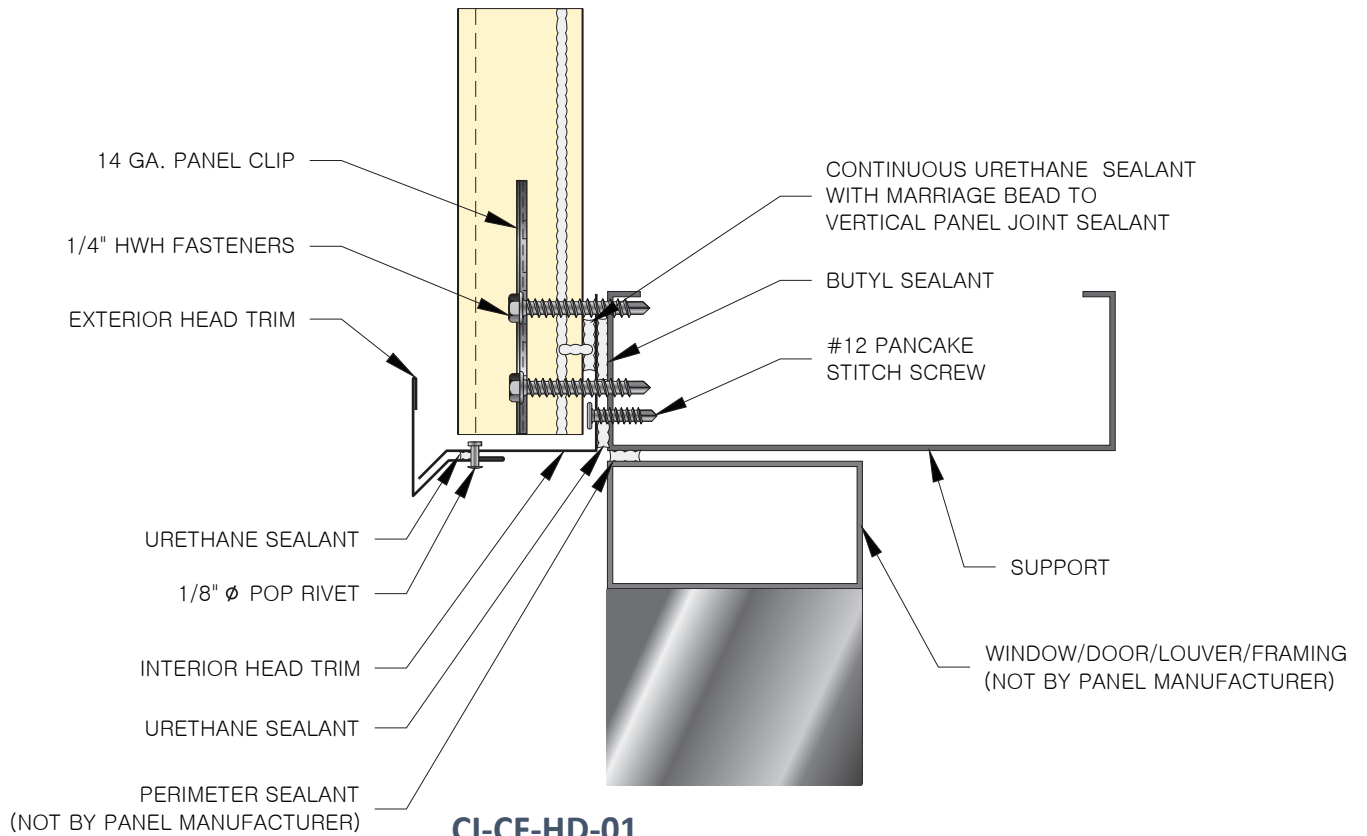

**CI-CF-HD-01
HEAD W/TWO PIECE TRIM**

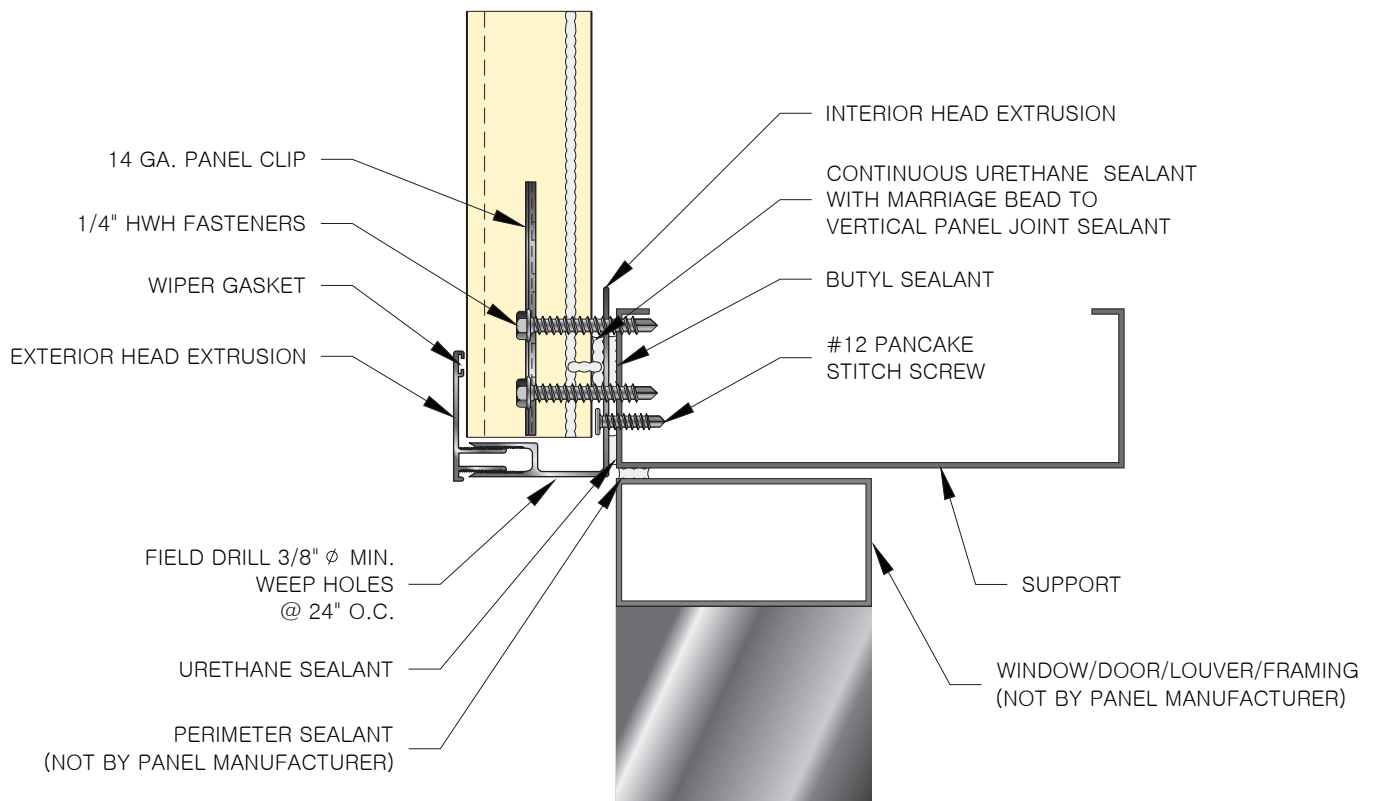

**CI-CF-EH-01
HEAD W/TWO PIECE EXTRUSION**

15. GENERAL DETAILS

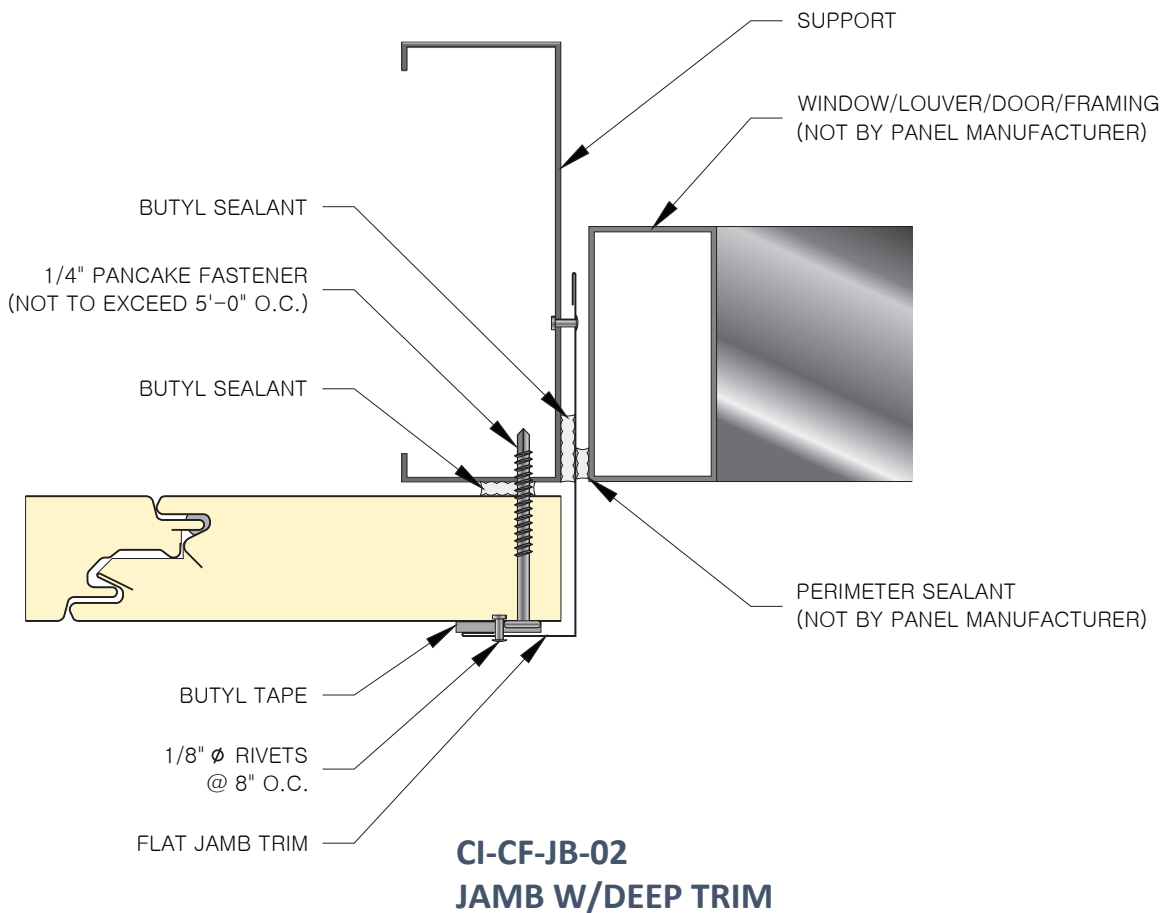
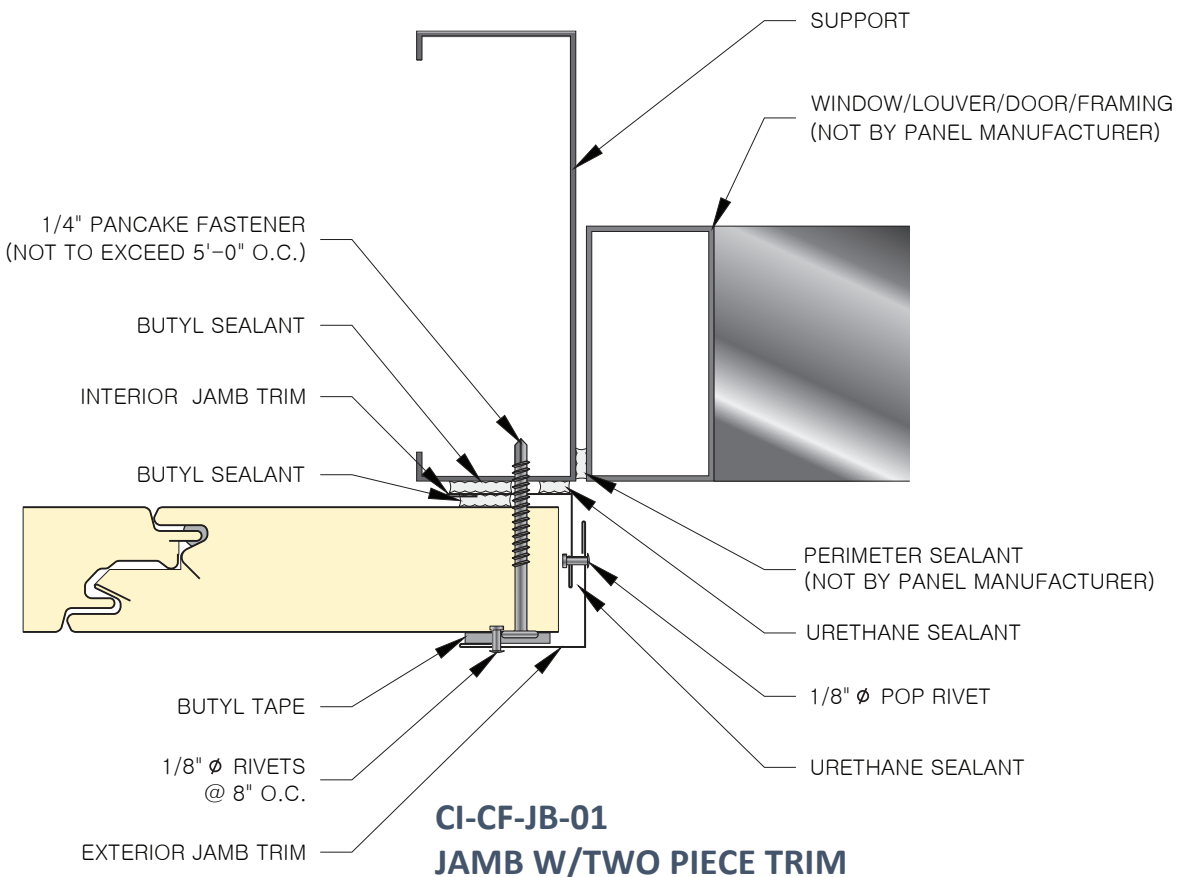

15. GENERAL DETAILS

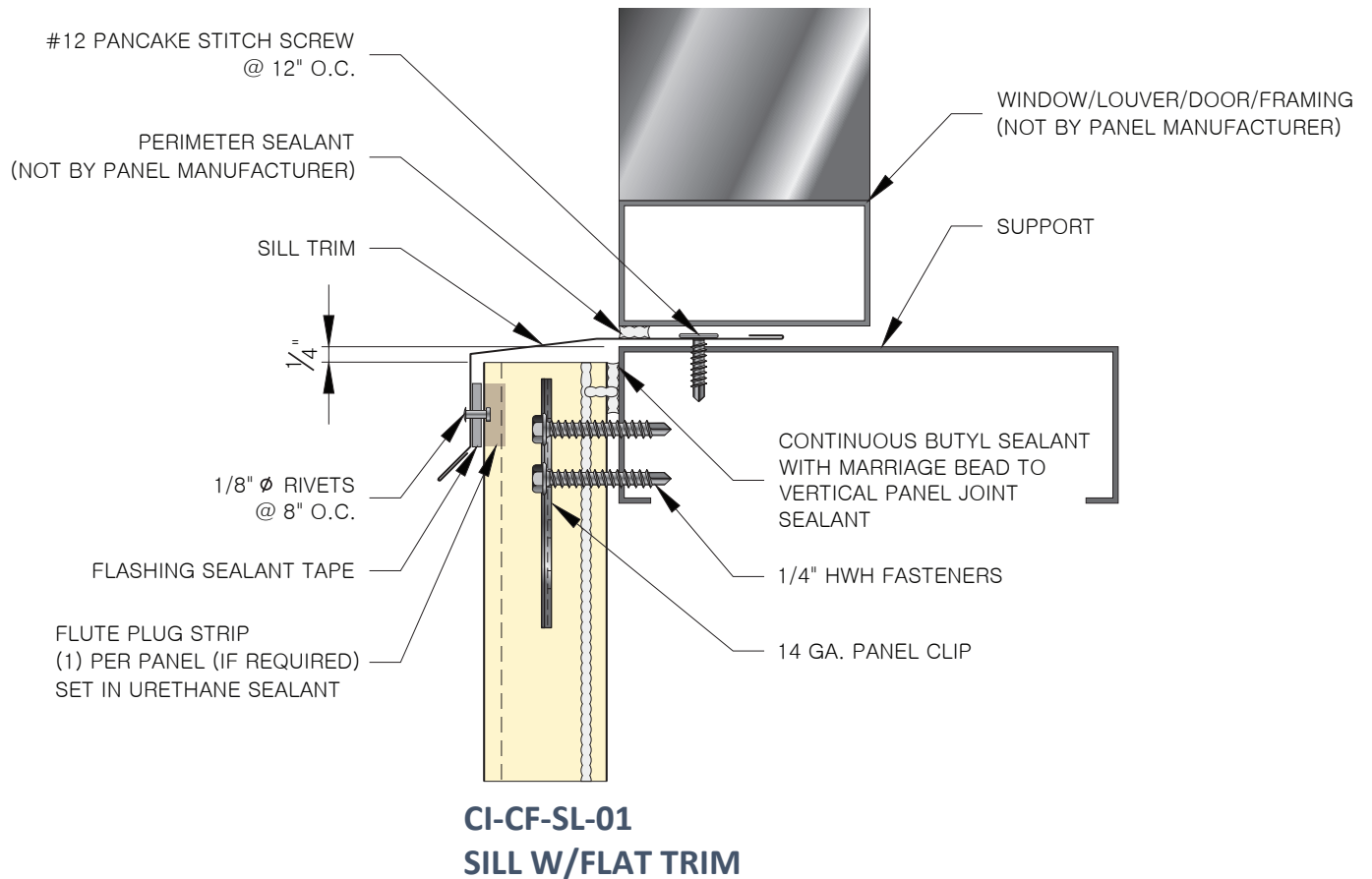
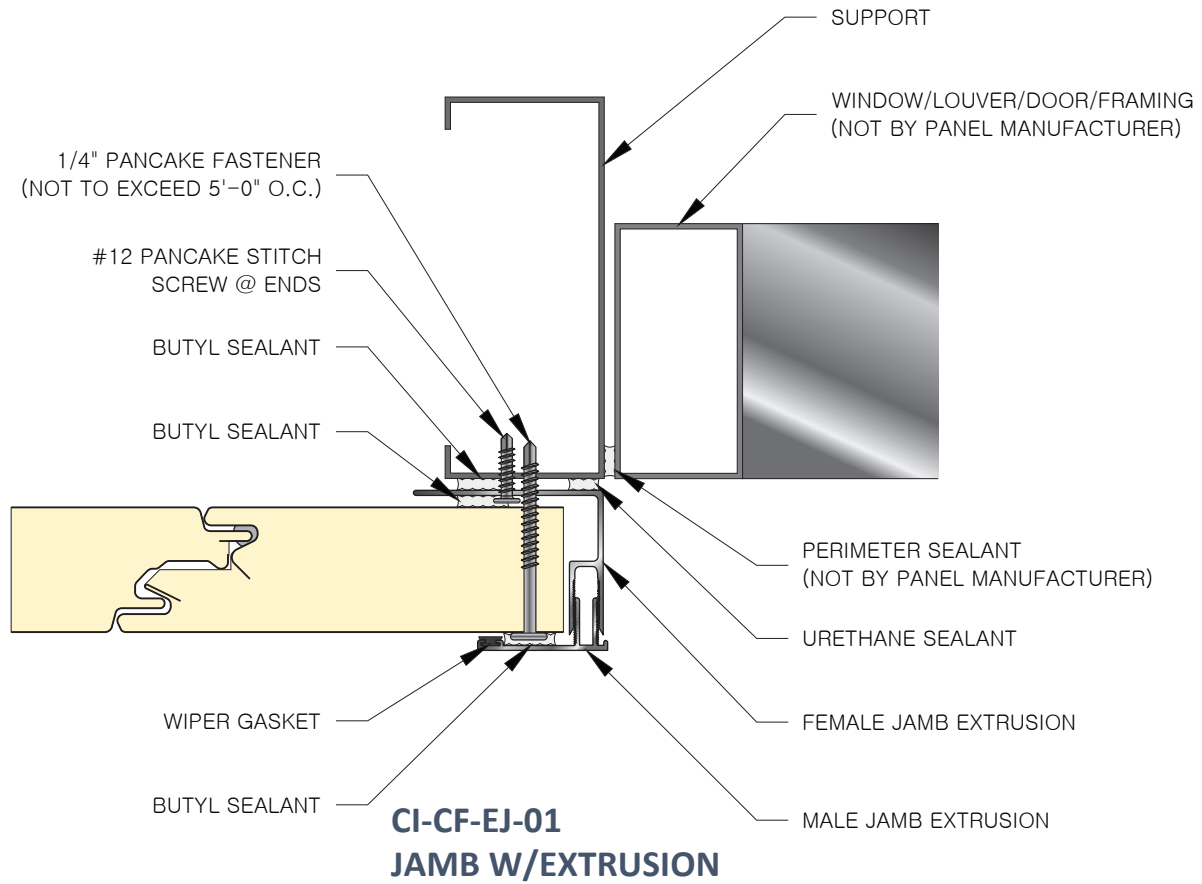

15. GENERAL DETAILS

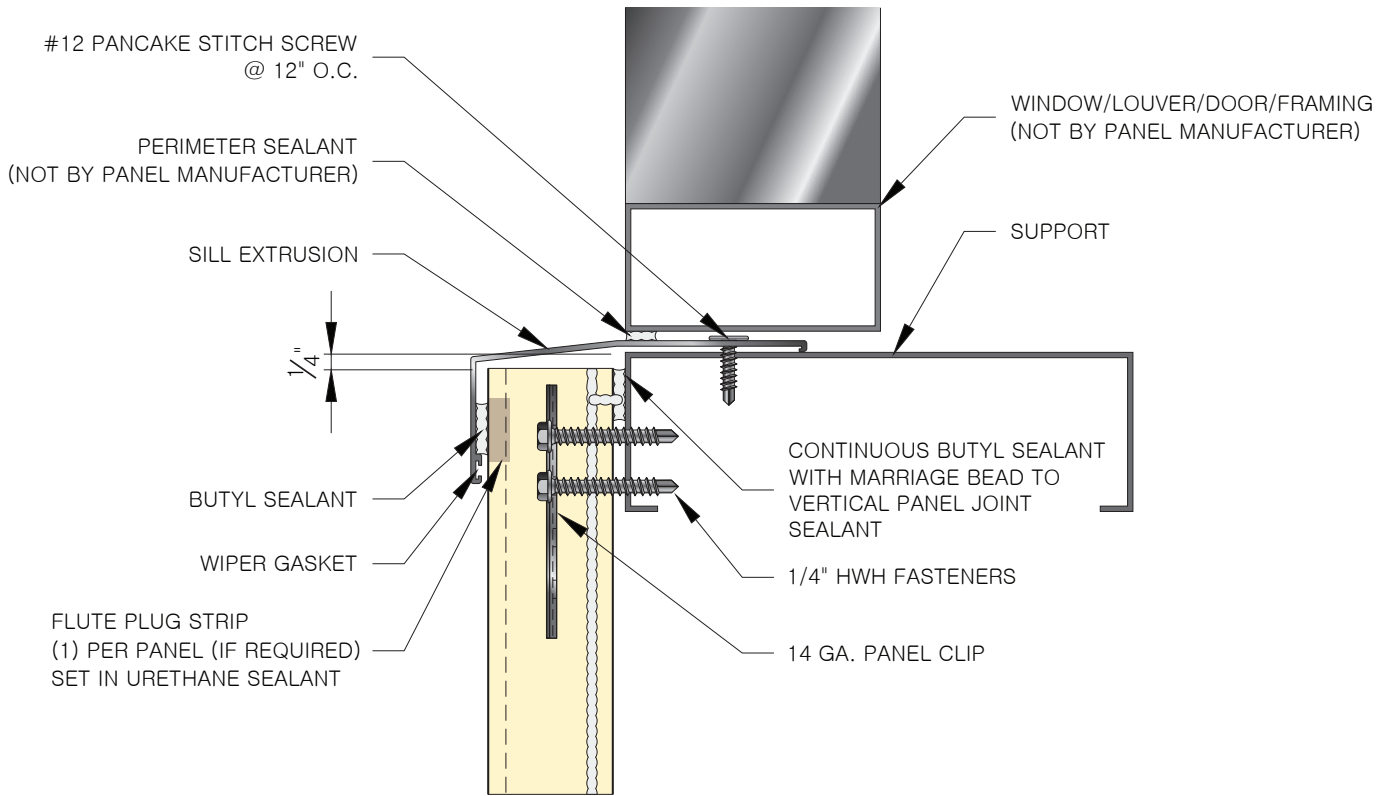

CI-CF-ES-01
SILL W/EXTRUSION

15. GENERAL DETAILS

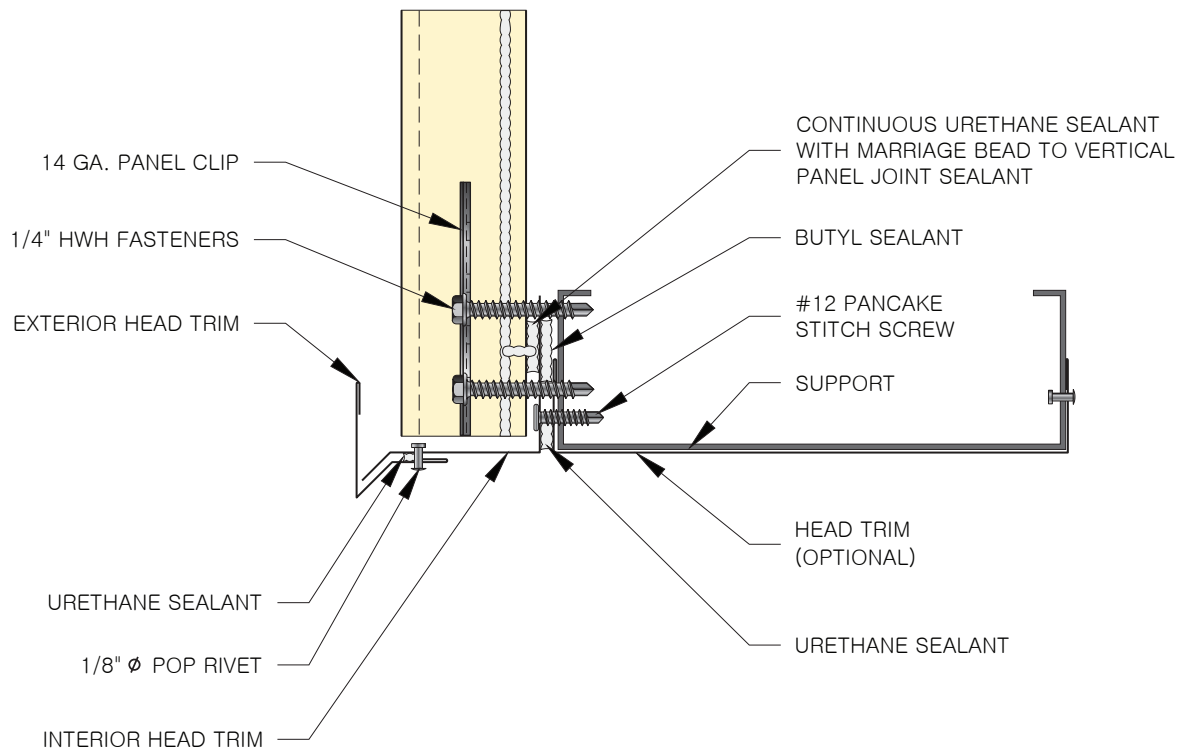

CI-CF-HD-02
O.H. DOOR HEAD W/TWO PIECE TRIM

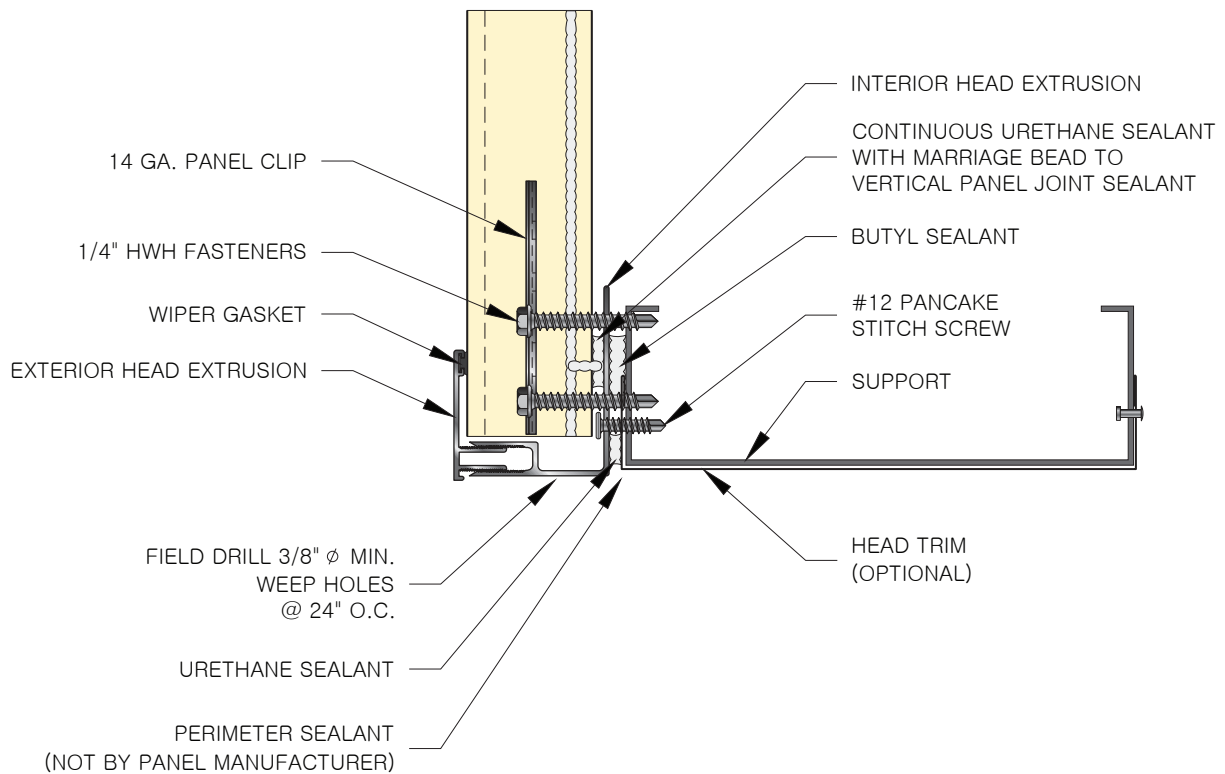

CI-CF-EH-02
O.H. DOOR HEAD W/TWO PIECE EXTRUSION

15. GENERAL DETAILS

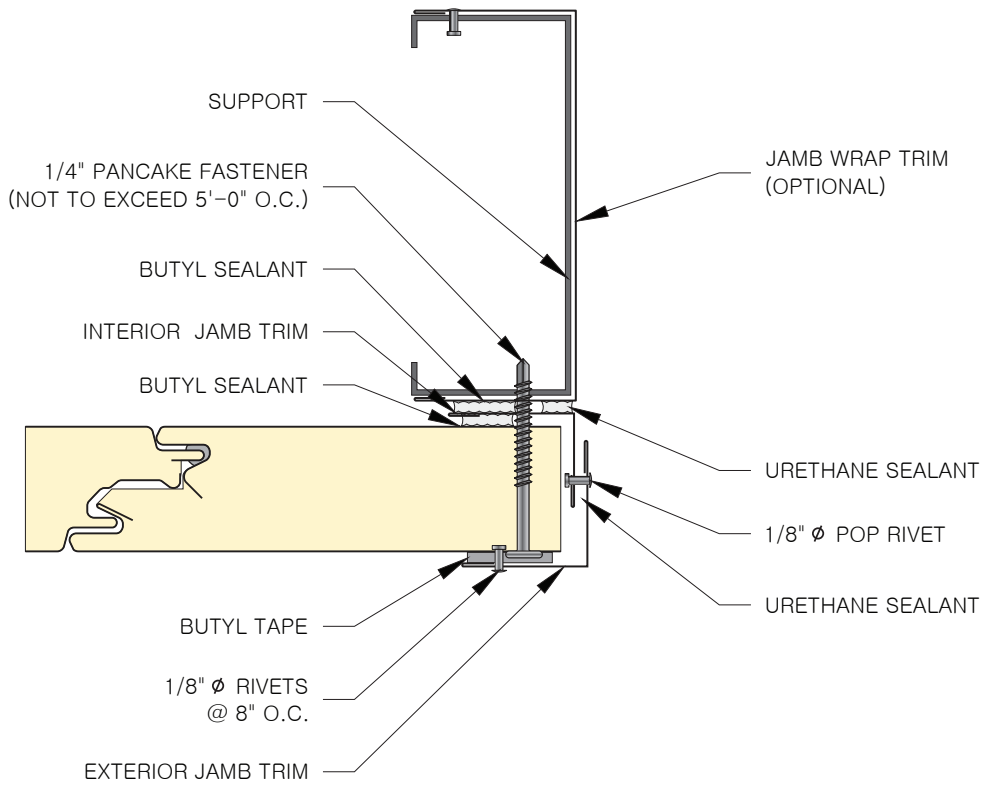

CI-CF-DJ-01
O.H. DOOR JAMB W/TWO PIECE TRIM

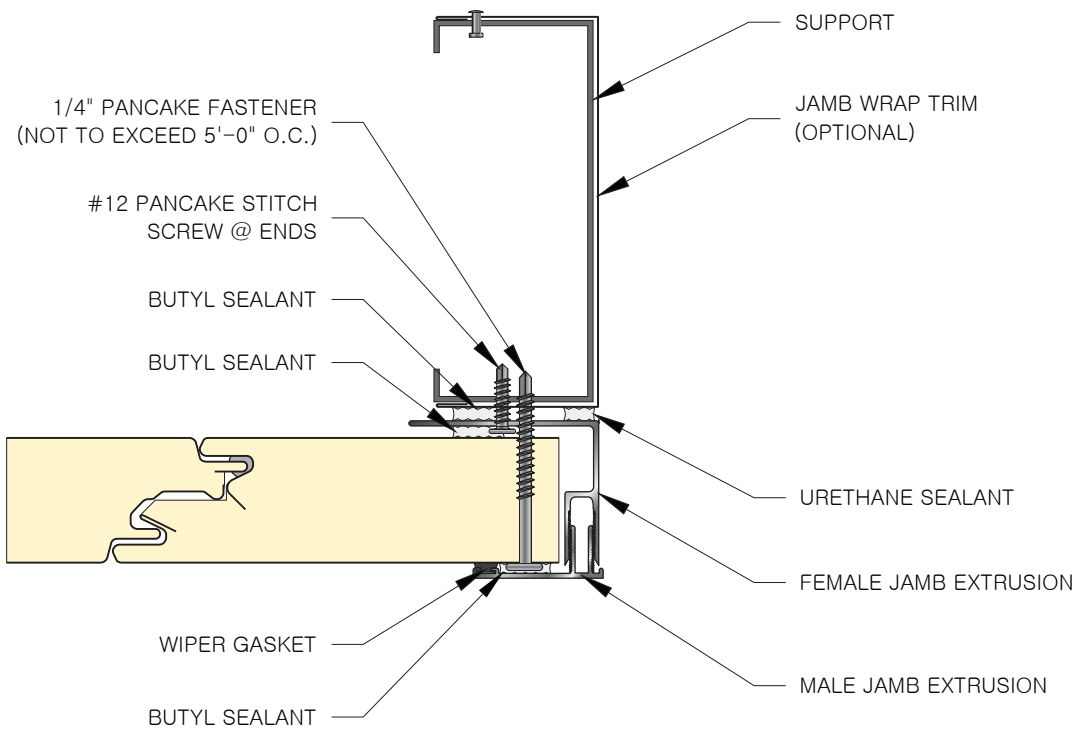

CI-CF-ED-01
O.H. DOOR JAMB W/EXTRUSION

15. GENERAL DETAILS

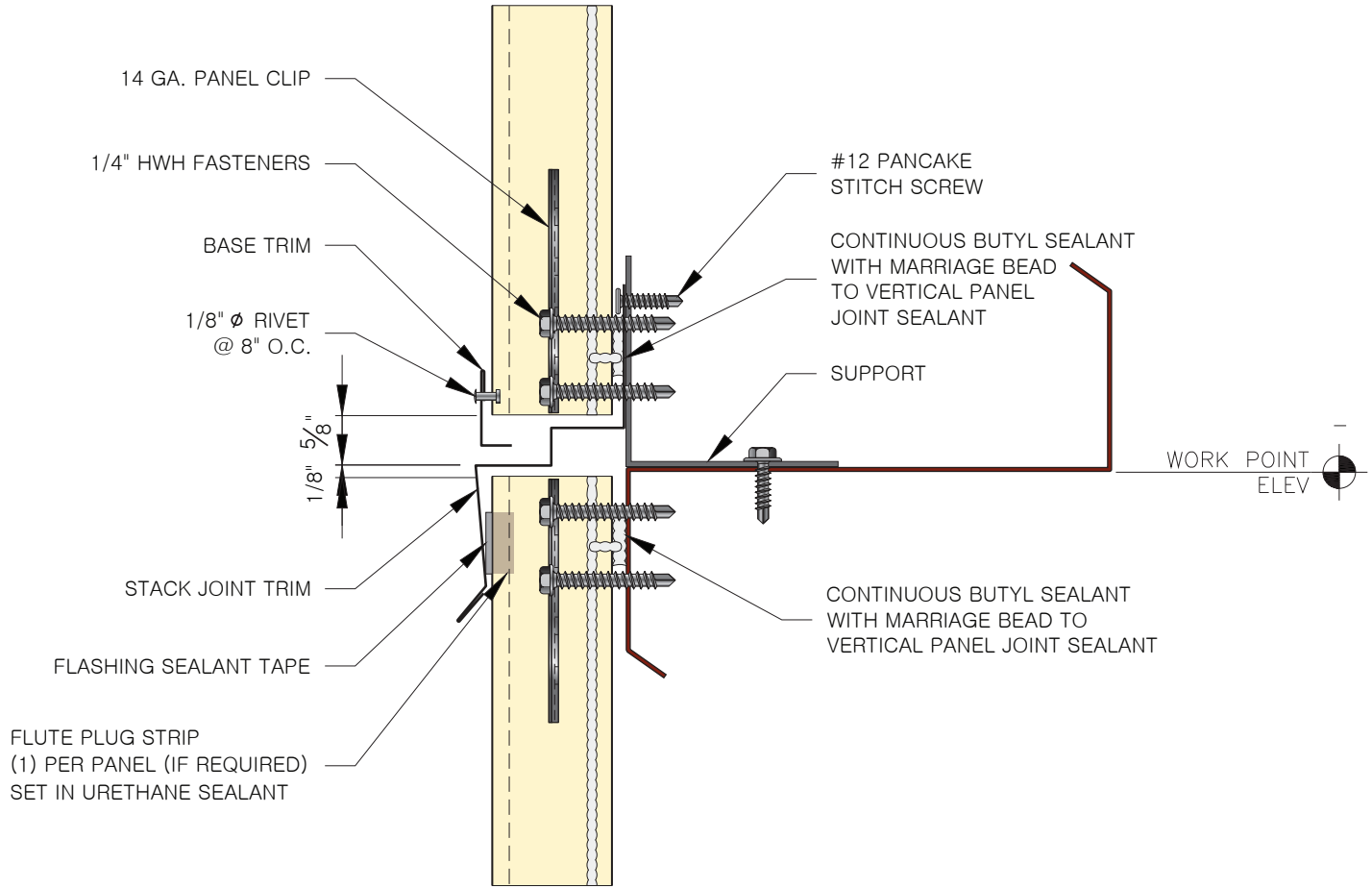

**CI-CF-SJ-01
STACK JOINT W/TRIM**

WARNING: VERIFY THAT STRUCTURAL SUPPORTS AT STACK JOINT LOCATION ARE OF PROPER GAUGE, LOCATION AND SIZE.

WARNING: IN ORDER TO ENSURE PROPER ALIGNMENT OF PANELS IT IS RECOMMENDED THAT BOTH LOWER AND UPPER ROWS ARE INSTALLED AT THE SAME TIME.

15. GENERAL DETAILS

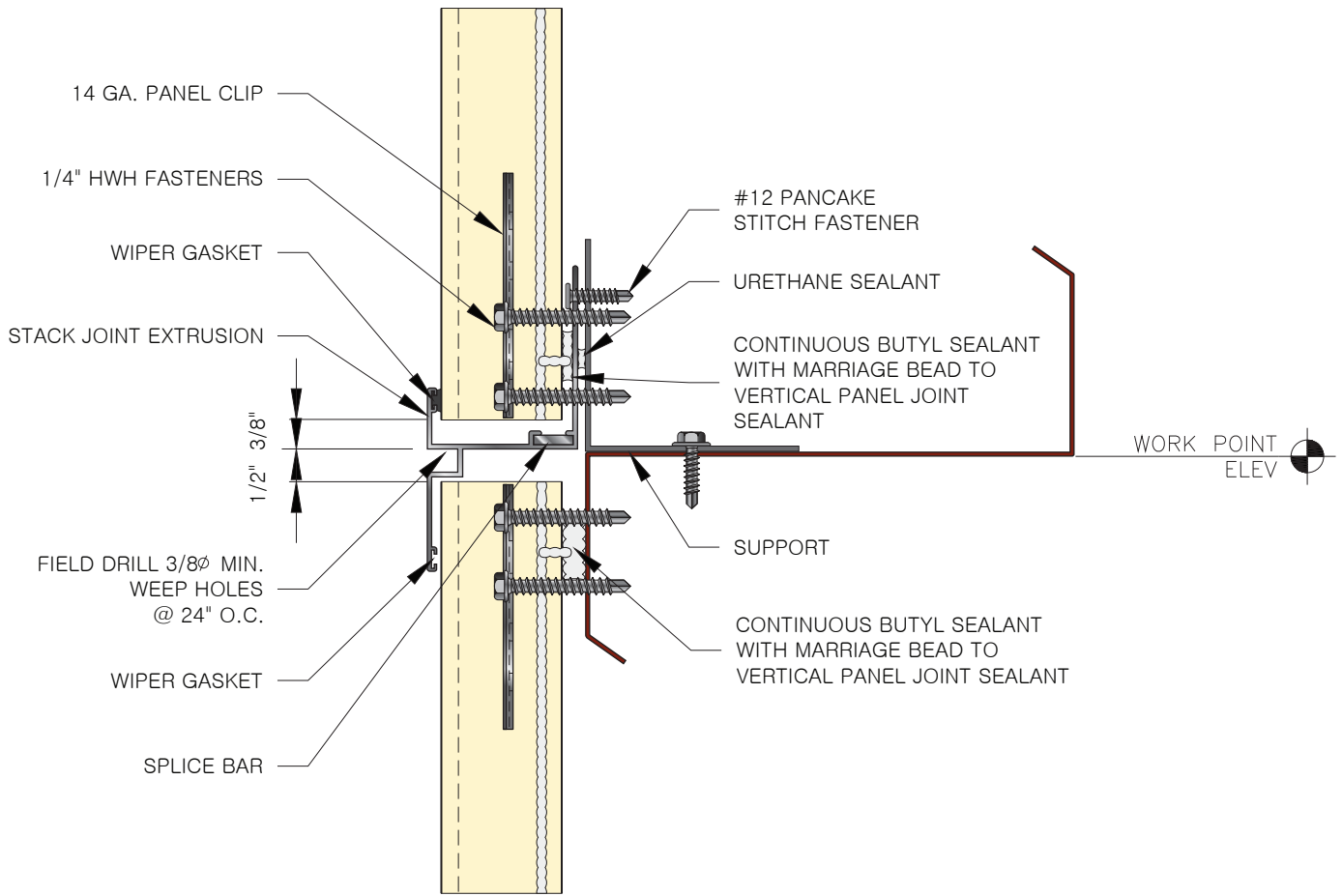

CI-CF-ESJ-01
STACK JOINT W/EXTRUSION

NOTE:
 THIS DETAIL IS FOR INFORMATIONAL
 PURPOSES ONLY. ALL ROOF COMPONENTS,
 PERIMETER FLASHING AND SEALANTS ARE
 NOT BY PANEL MANUFACTURER.

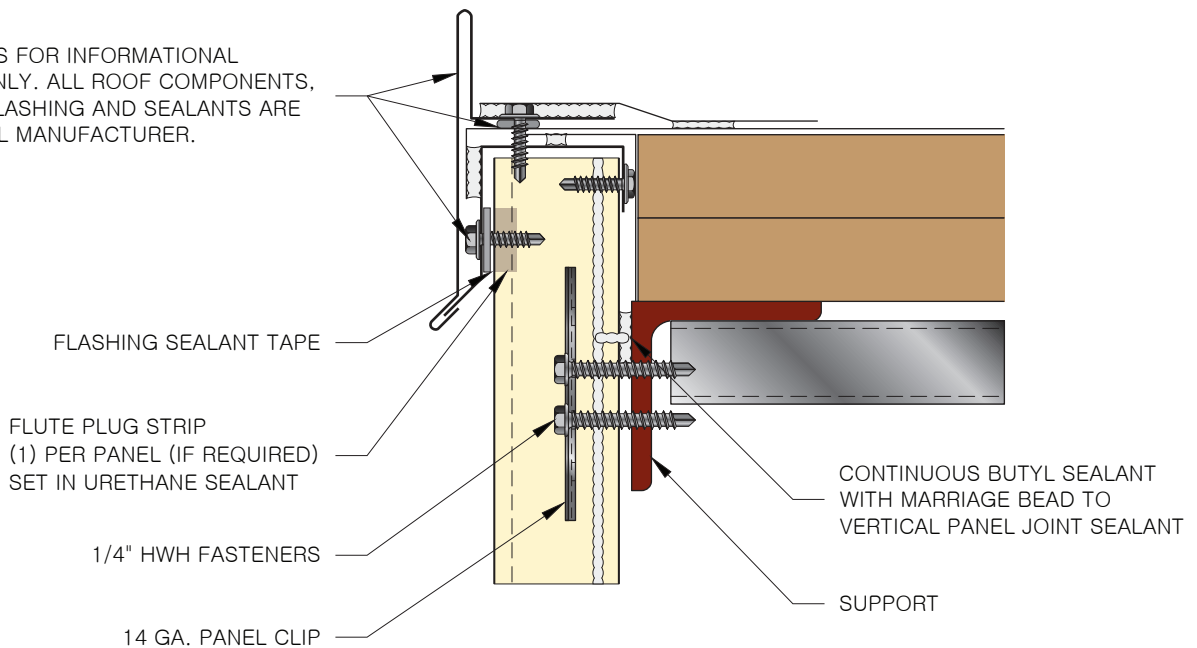

CI-CF-VE-01
EAVE - CONVENTIONAL ROOF

15. GENERAL DETAILS

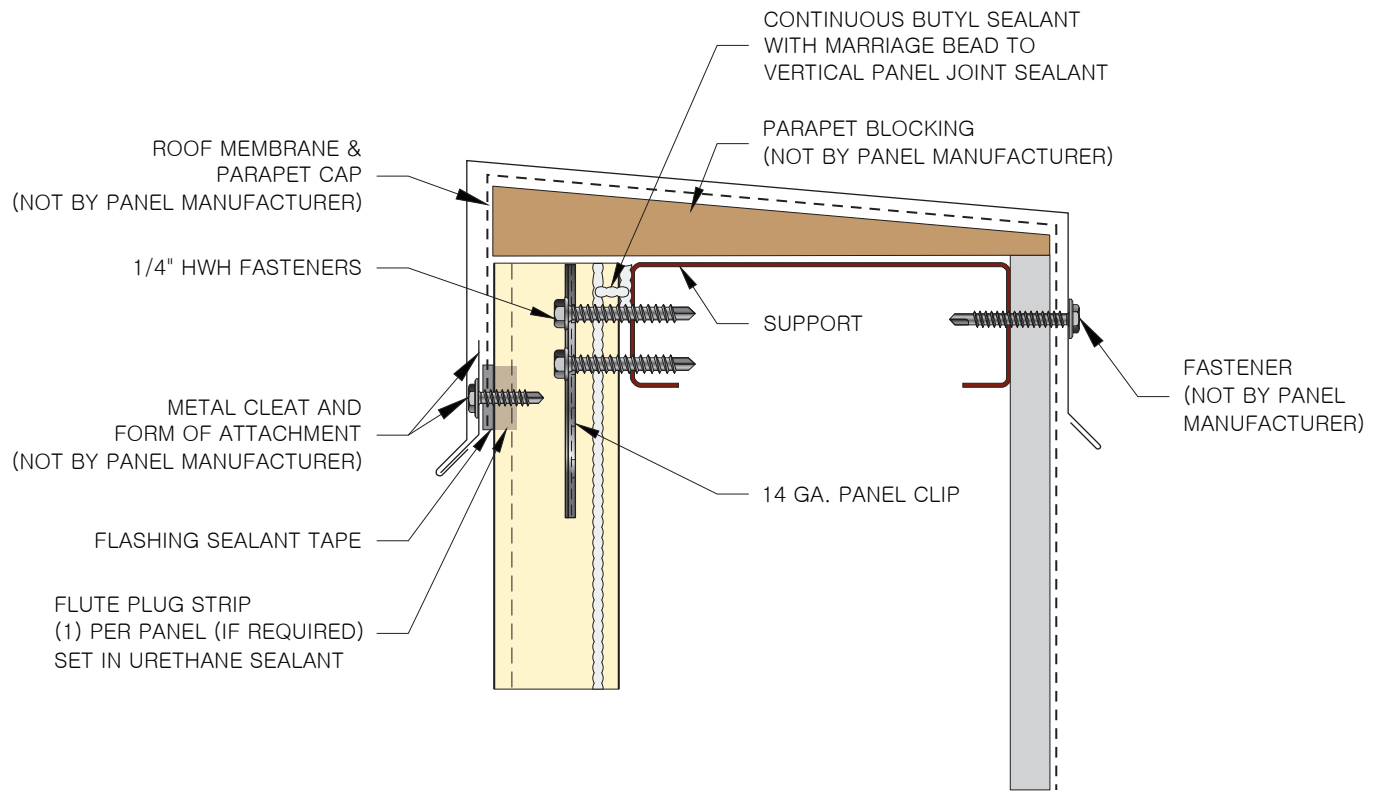

CI-CF-TP-01
PARAPET (SUPPORTED) W/TRIM

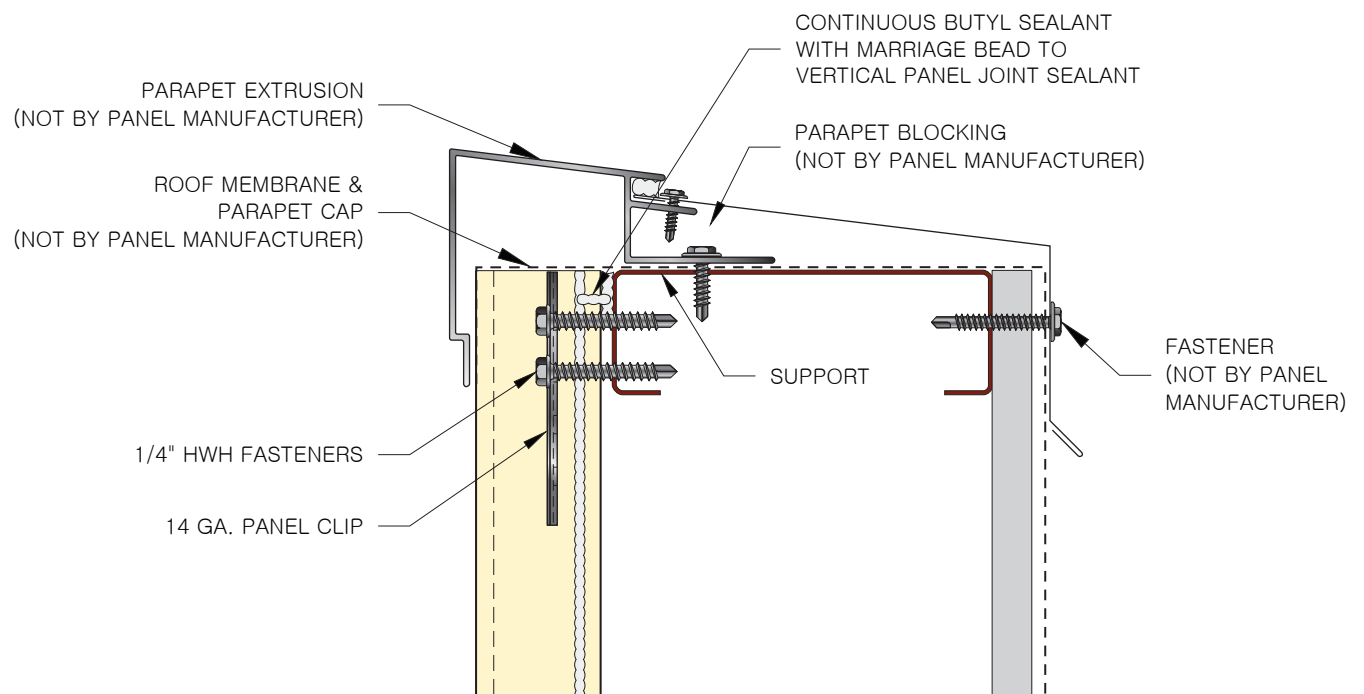

CI-CF-EP-02
PARAPET (SUPPORTED W/EXTRUSION)

15. GENERAL DETAILS

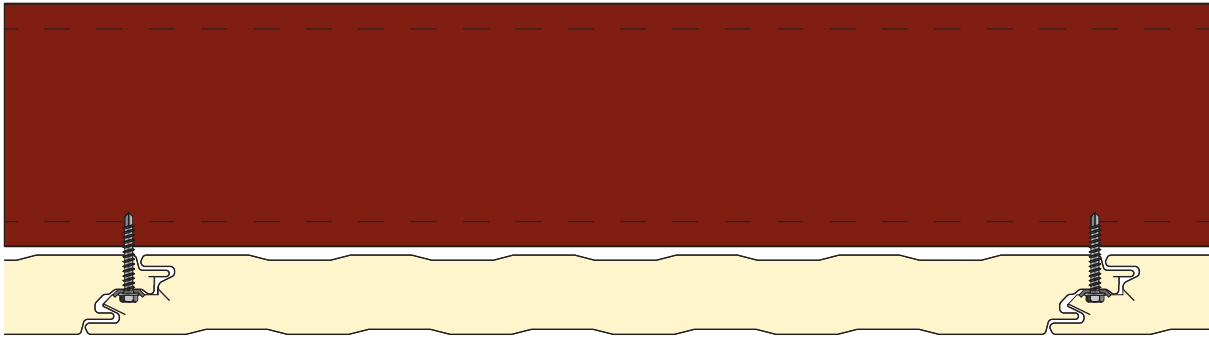

(FP1)

CI-CF-FP 1 FASTENING PATTERN #1

DIMENSION IS FROM
FEMALE EDGE +/- 1.5"

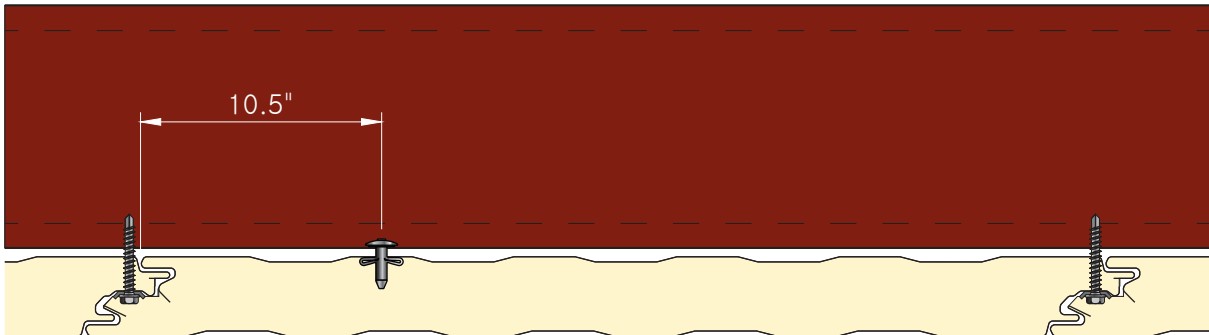

(FP2)

SIDE JOINT FASTENING
AND ONE DOME HEAD
BULB-TITE® RIVET

INSTALL RIVET THROUGH GIRT FLANGE
INTO MESA WHERE THE SKIN MAKES
CONTACT WITH THE STEEL

CI-CF-FP 2 FASTENING PATTERN #2

DIMENSION IS FROM
FEMALE EDGE +/- 1.5"

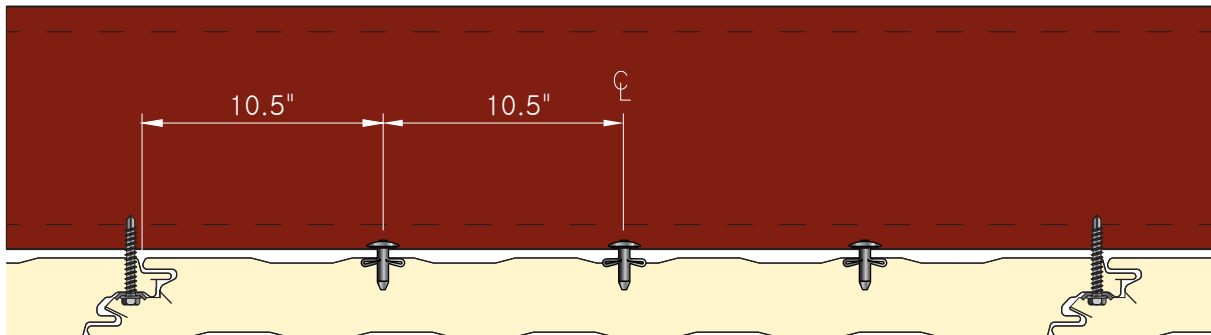

(FP3)

SIDE JOINT FASTENING
AND TWO DOME HEAD
BULB-TITE® RIVETS

INSTALL RIVET THROUGH GIRT FLANGE
INTO MESA WHERE THE SKIN MAKES
CONTACT WITH THE STEEL

CI-CF-FP 3 FASTENING PATTERN #3

15. GENERAL DETAILS

DIMENSION IS FROM
FEMALE EDGE +/- 1.5"

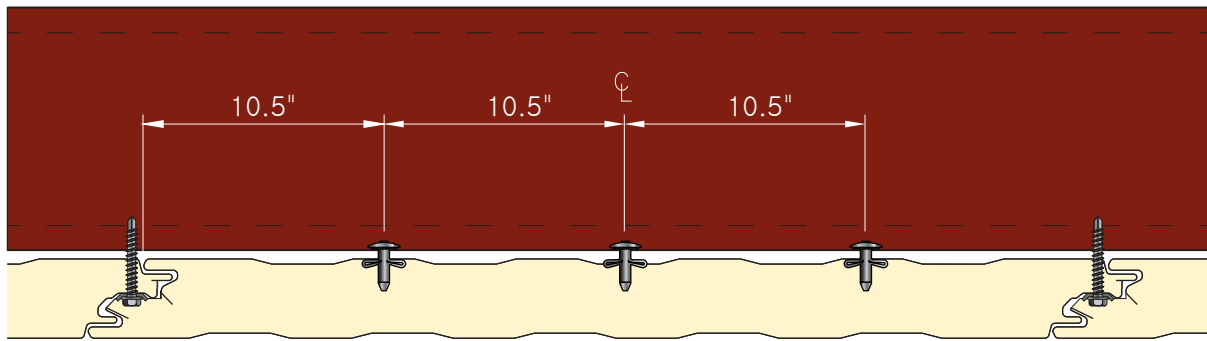

(FP4) SIDE JOINT FASTENING
WITH THREE DOME HEAD
BULB-TITE® RIVETS

INSTALL RIVET THROUGH GIRT FLANGE
INTO MESA WHERE THE SKIN MAKES
CONTACT WITH THE STEEL

CI-CF-FP 4 FASTENING PATTERN #4

DIMENSION IS FROM
FEMALE EDGE +/- 1.5"

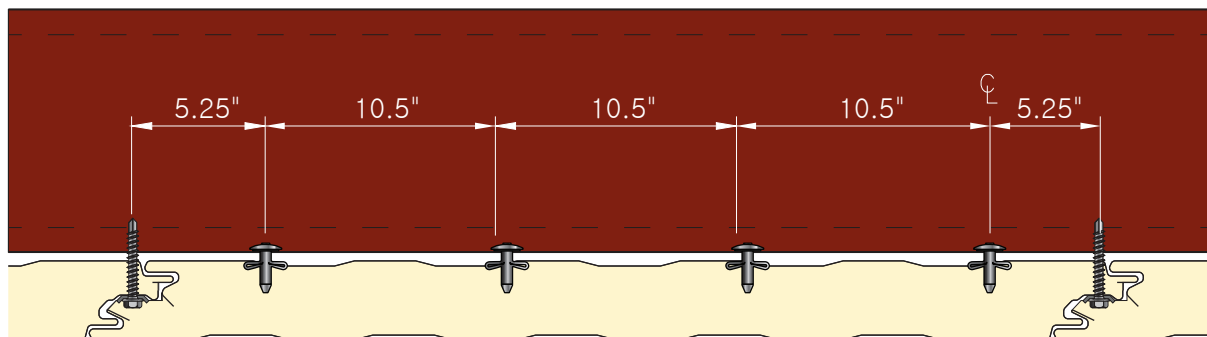

(FP5) SIDE JOINT FASTENING
AND FOUR DOME HEAD
BULB-TITE® RIVETS

INSTALL RIVET THROUGH GIRT FLANGE
INTO MESA WHERE THE SKIN MAKES
CONTACT WITH THE STEEL

CI-CF-FP 5 FASTENING PATTERN #5

DIMENSION IS FROM
FEMALE EDGE +/- 1.5"

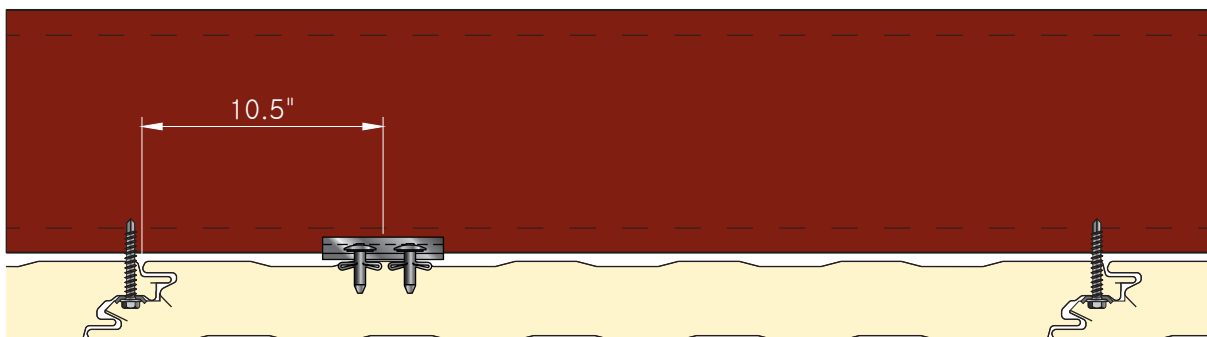

(FP6) SIDE JOINT FASTENING
AND ONE GIRT CLIP WITH TWO
DOME HEAD BULB-TITE® RIVETS

INSTALL RIVET THROUGH GIRT FLANGE
INTO MESA WHERE THE SKIN MAKES
CONTACT WITH THE STEEL

CI-CF-FP 6 FASTENING PATTERN #6

15. GENERAL DETAILS

DIMENSION IS FROM
FEMALE EDGE +/- 1.5"

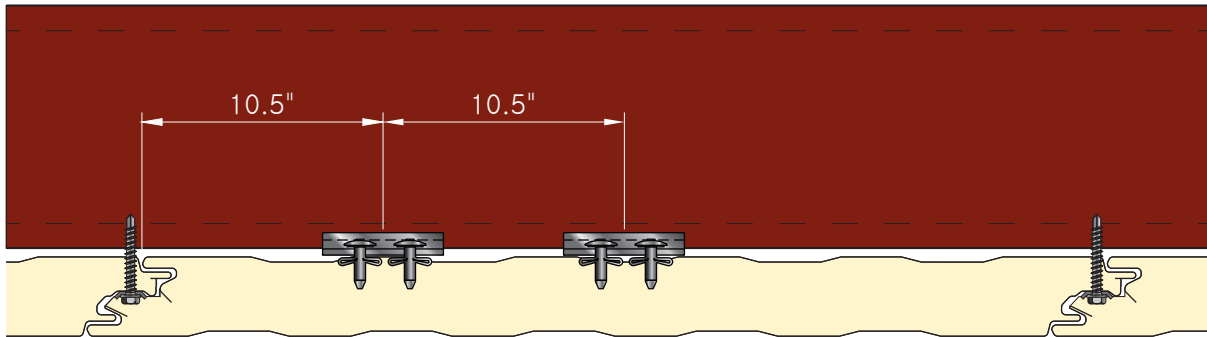

(FP7) SIDE JOINT FASTENING
AND TWO GIRT CLIPS WITH FOUR
DOME HEAD BULB-TITE® RIVETS

INSTALL RIVET THROUGH GIRT FLANGE
INTO MESA WHERE THE SKIN MAKES
CONTACT WITH THE STEEL

CI-CF-FP 7 FASTENING PATTERN #7

DIMENSION IS FROM
FEMALE EDGE +/- 1.5"

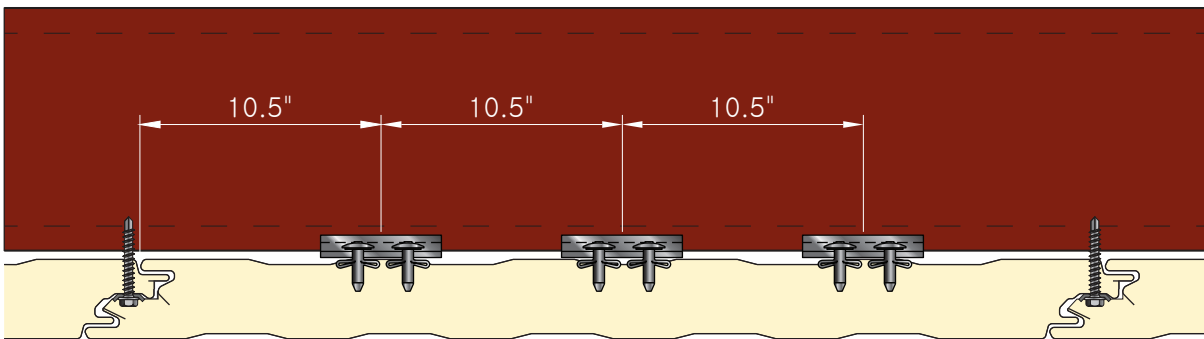

(FP8) SIDE JOINT FASTENING
WITH THREE GIRT CLIPS WITH SIX
DOME HEAD BULB-TITE® RIVETS

INSTALL RIVET THROUGH GIRT FLANGE
INTO MESA WHERE THE SKIN MAKES
CONTACT WITH THE STEEL

CI-CF-FP 8 FASTENING PATTERN #8

15. GENERAL DETAILS

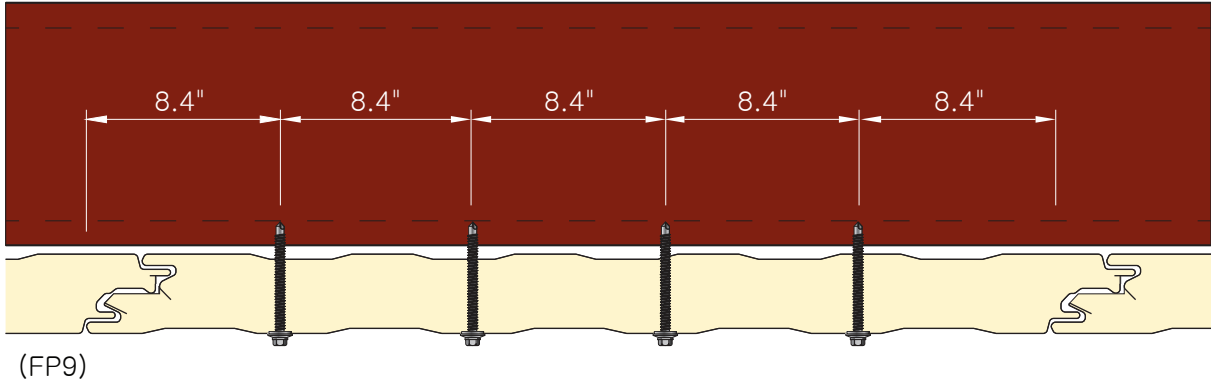

FOUR SELF-TAPPING SCREWS
WITH MIN. 20 GA. NEOPRENE
BONDED WASHER

CI-CF-FP 9 FASTENING PATTERN #9

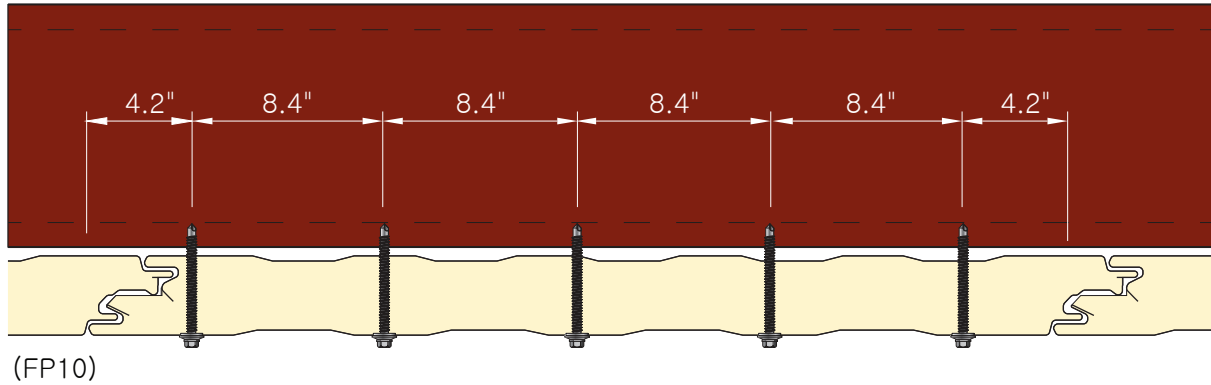

FIVE SELF-TAPPING SCREWS
WITH MIN. 20 GA. NEOPRENE
BONDED WASHER

CI-CF-FP 10 FASTENING PATTERN #10

16. PENETRATIONS - PIPE

16.1 Locate penetration(s) on wall panel and cut hole with 1/2" minimum clearance.
(Refer to Chapter 7 for panel cutting instructions).

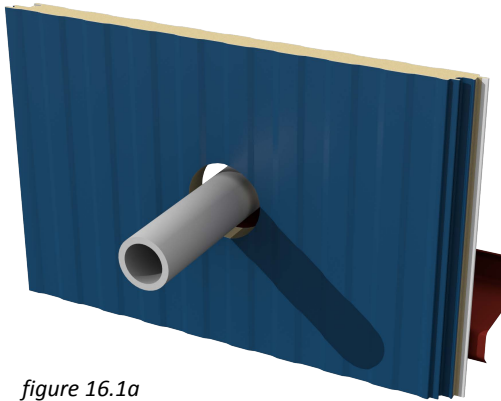

figure 16.1a

Penetration through field of panel

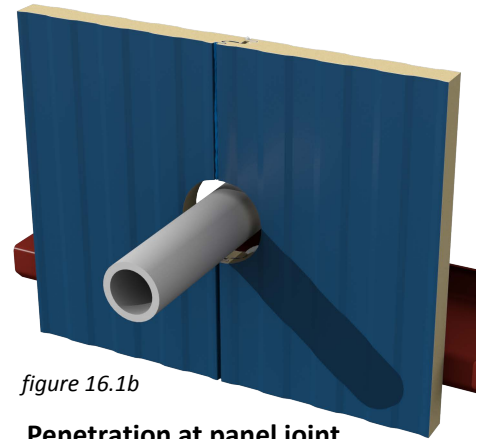

figure 16.1b

Penetration at panel joint

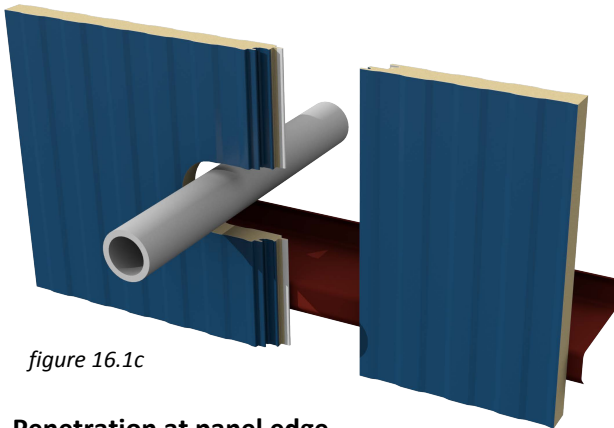

figure 16.1c

Penetration at panel edge

16.2 For penetrations at panel joints or edges:

- plug interior joint above and below opening with butyl sealant (figure 16.2a)
- fill *exterior* reveal above penetration with color matched urethane sealant (not by panel manufacturer) to top of panel (figure 16.2b)

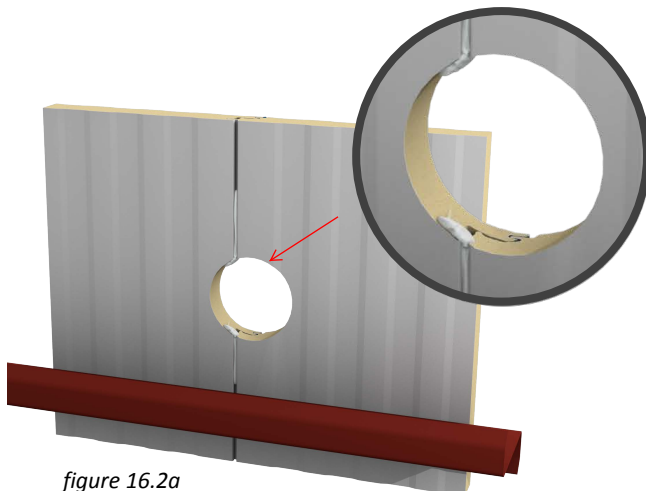

figure 16.2a



figure 16.2b

16. PENETRATIONS - PIPE



figure 16.3a

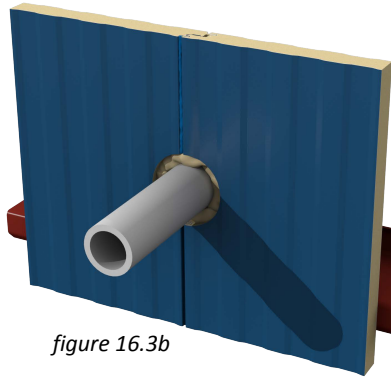

figure 16.3b

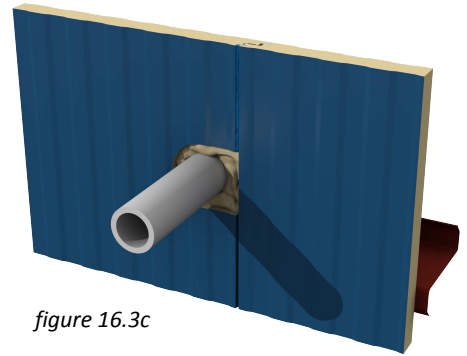

figure 16.3c

16.3 Fill gap around penetration(s) with expandable foam.

16.4 Apply urethane sealant around penetration(s). Cut sheet metal trims for lower and upper halves of opening and attach using 1/8" painted stainless steel pop rivets.

16.5 Apply 3/8" minimum bead of color matched urethane sealant around penetration(s).

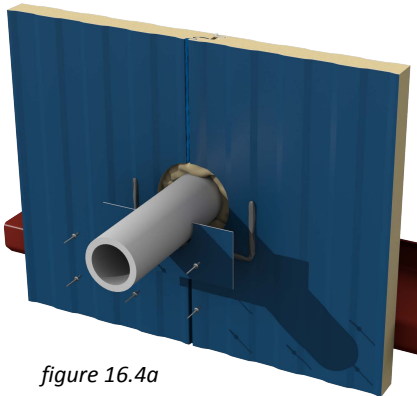

figure 16.4a

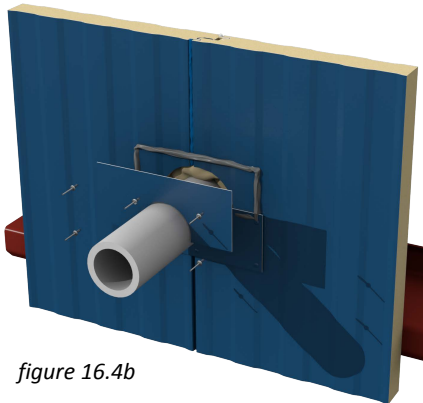

figure 16.4b

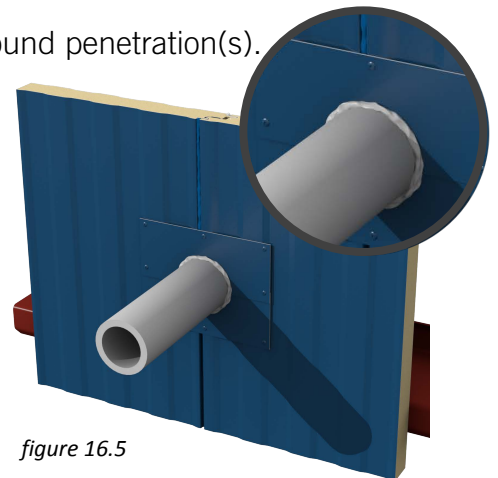

figure 16.5

16.6 Repeat steps 16.4 and 16.5 for interior side.

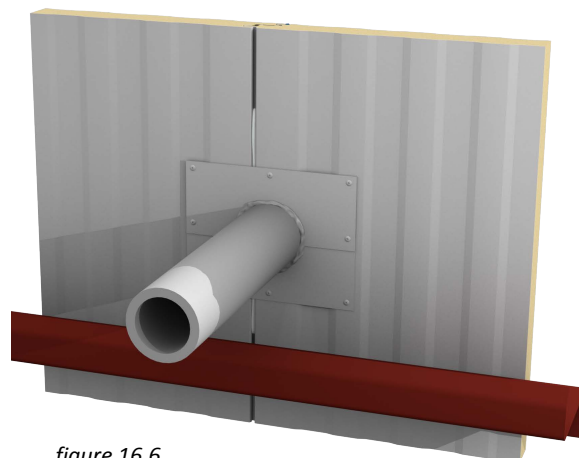

figure 16.6

16. PENETRATIONS - BEAM

16.7 Locate penetration(s) on wall panel and cut hole with 1/2" minimum clearance. (Refer to Chapter 7 for panel cutting instructions).

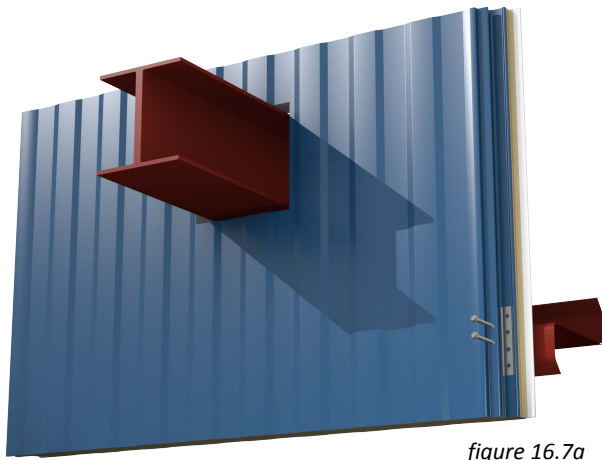

figure 16.7a

Penetration through middle of panel

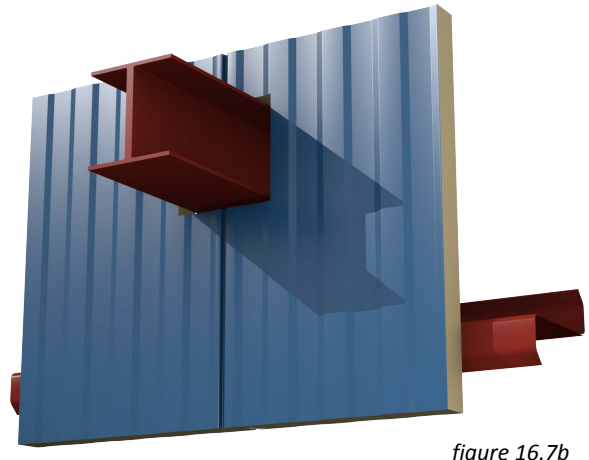

figure 16.7b

Penetration at panel joint

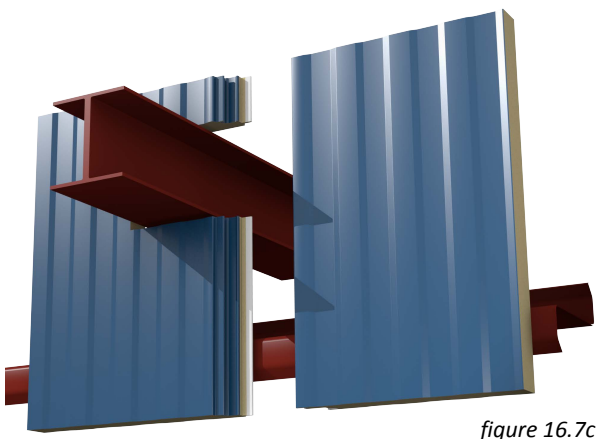

figure 16.7c

Penetration at panel edge

16.8 For penetrations at panel joints or edges:

- plug interior joint above and below opening with butyl sealant (figure 16.8a)
- fill exterior reveal above penetration with color matched urethane sealant (not by panel manufacturer) to top of panel (figure 16.8b)

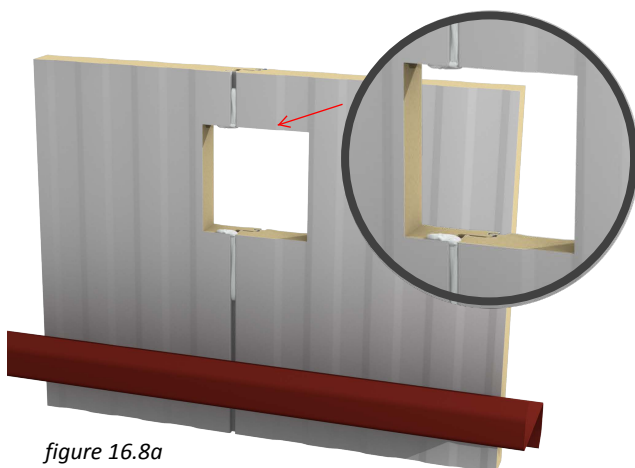

figure 16.8a



figure 16.8b

16. PENETRATIONS - BEAM



figure 16.9a

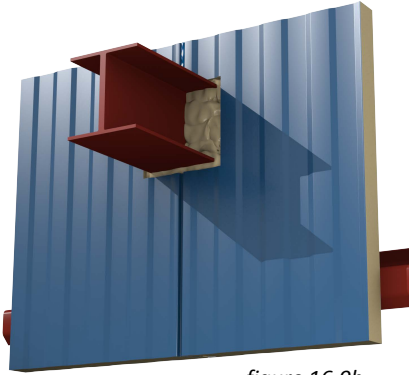

figure 16.9b

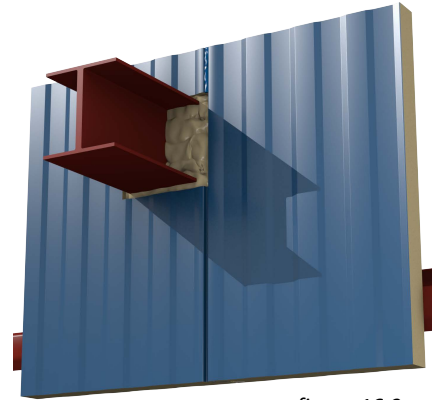

figure 16.9c

16.9 Fill gap around penetration(s) with expandable foam.

16.10 Apply urethane sealant around penetration(s). Cut sheet metal trims for lower and upper halves of opening and attach using 1/8" painted stainless steel pop rivets.

16.11 Apply 3/8" minimum bead of color matched urethane sealant around penetration(s).

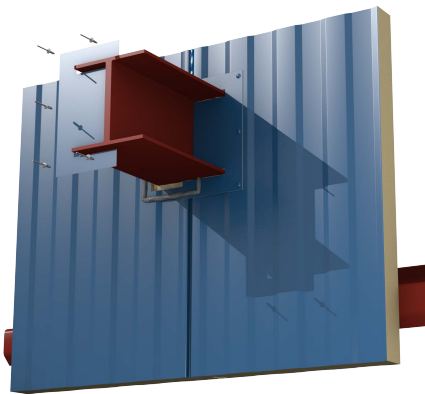

figure 16.10a

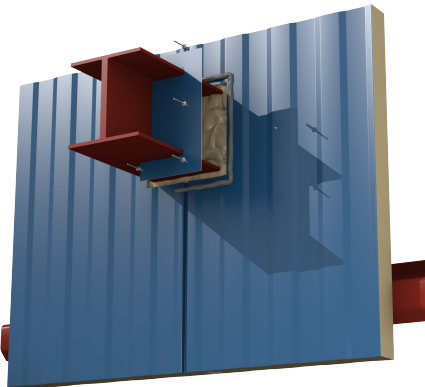

figure 16.10b

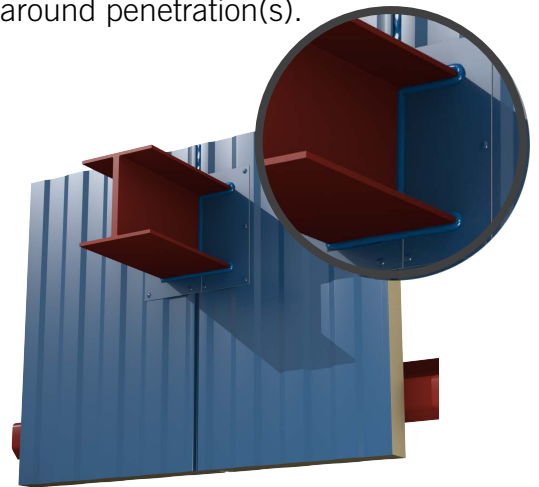

figure 16.11

16.12 Repeat steps 16.10 and 16.11 for interior side.

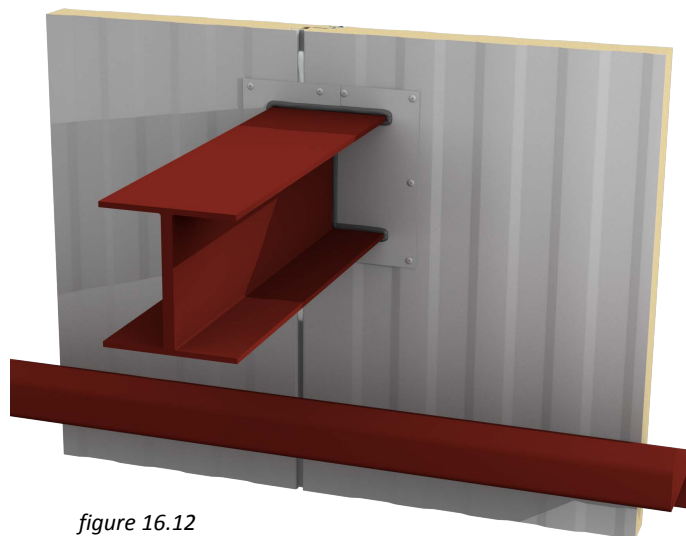
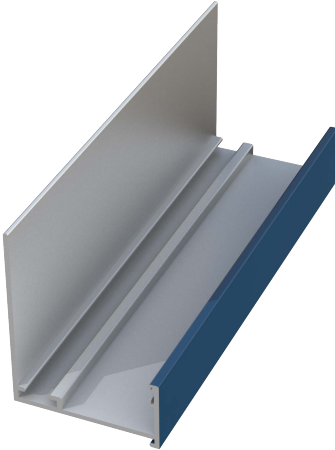

figure 16.12

17. EXTRUSIONS

CHECK W/METL-SPAN FOR AVAILABILITY: NOT ALL EXTRUSIONS ARE AVAILABLE FOR ALL PANEL THICKNESSES.



Base

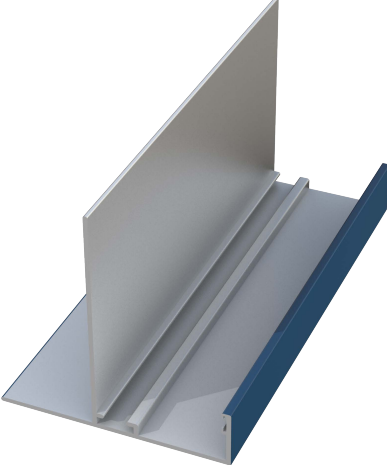

Soffit

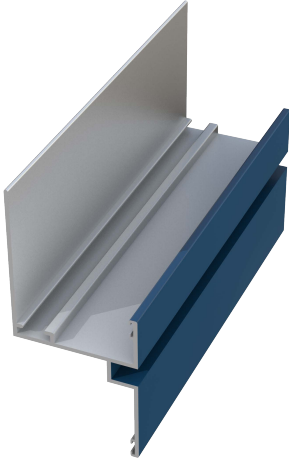

Stack Joint

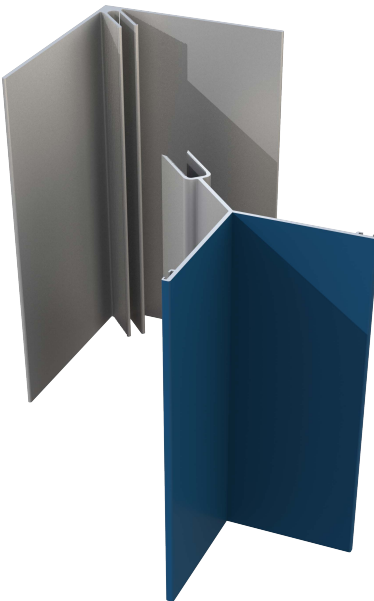

Inside Corner

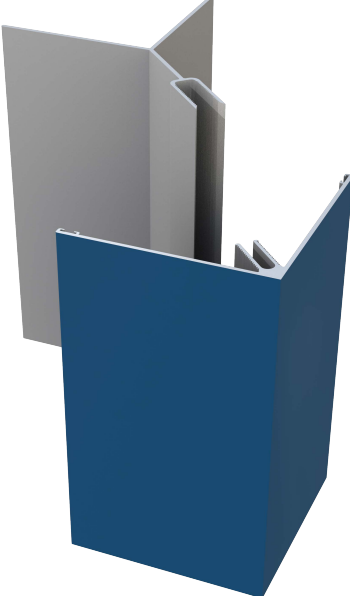

Outside Corner

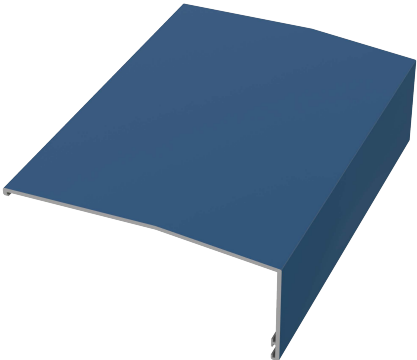

Sill

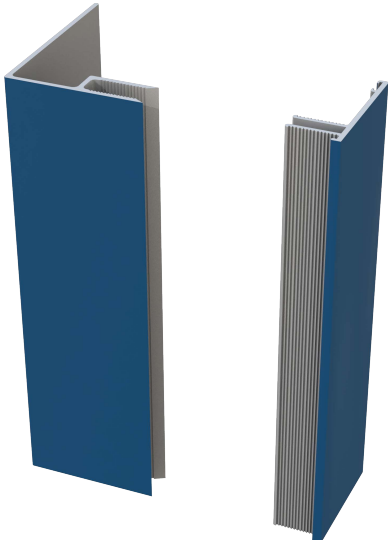

Jamb/Head

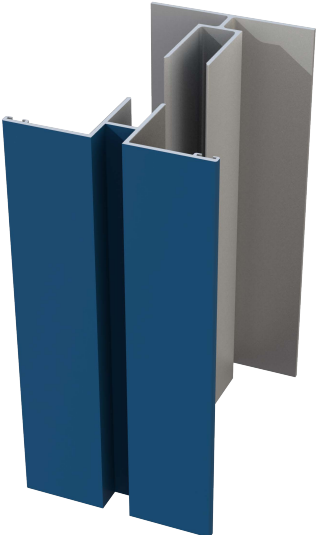

Vertical H Joint

OPTIONAL WIPER GASKETS AND SPLICE BARS

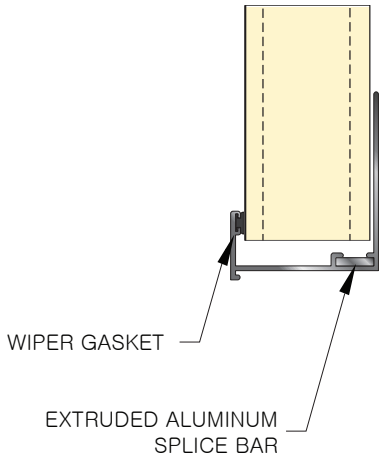

17. EXTRUSIONS

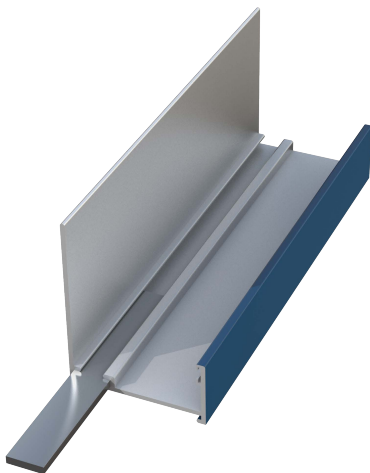

Base

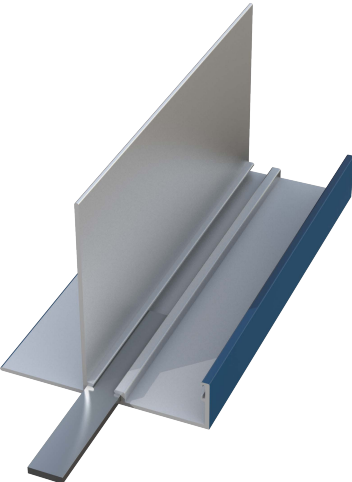

Soffit

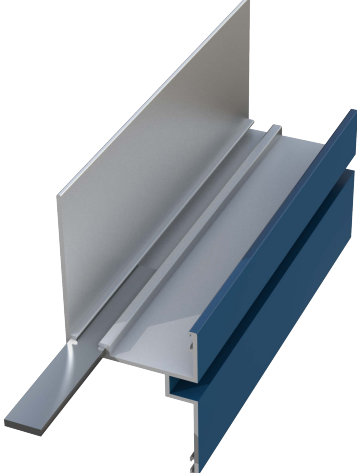

Stack Joint

ALUMINUM SPLICE BARS ARE USED TO ALIGN THESE EXTRUSIONS AT LAP JOINTS.

LAP STRIPS ARE MADE FROM FLAT STOCK, COLOR TO MATCH EXTRUSIONS.

LAP STRIPS ARE USED:
1. FOR IMPROVED APPEARANCE AT SPLICES
2. TO PROTECT AGAINST LEAKS AT SPLICES

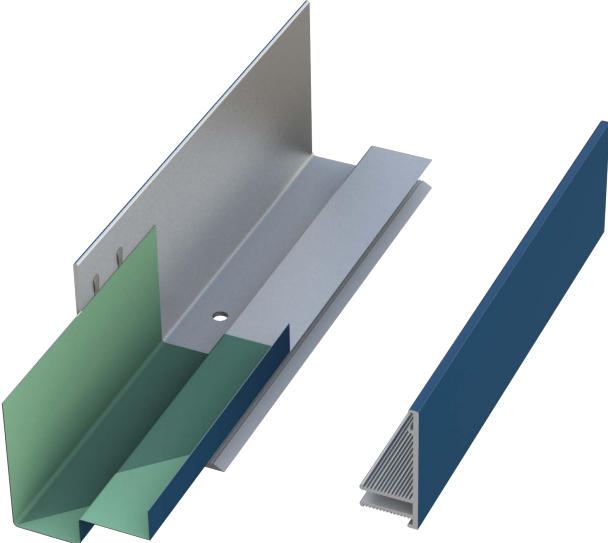
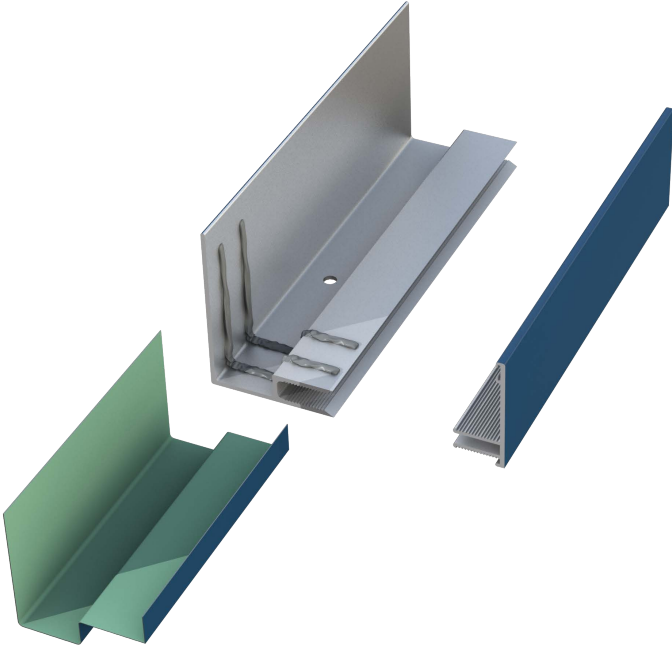

WARNING: FOR FRAMED OPENING HEAD CONDITIONS WITH SPLICES, SET EACH END OF LAP STRIP IN 2 ROWS OF URETHANE SEALANT. DRILL WEEP HOLES IN EXTRUSIONS WITHIN 2" OF SPLICE.

17. EXTRUSIONS - LAP STRIPS

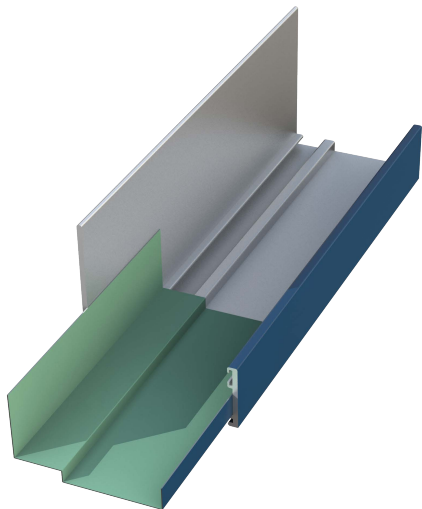

Base

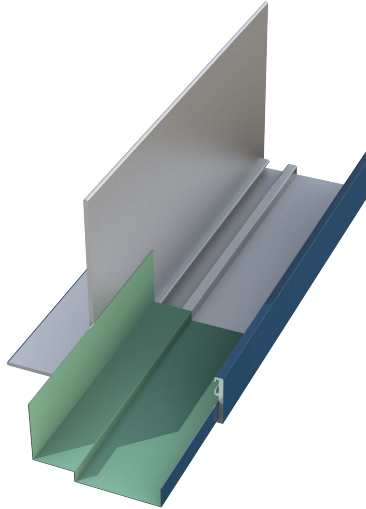

Soffit

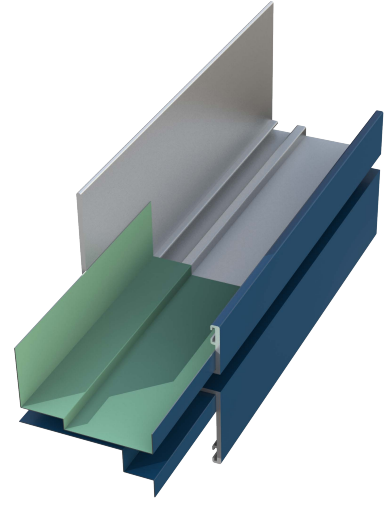

Stack Joint

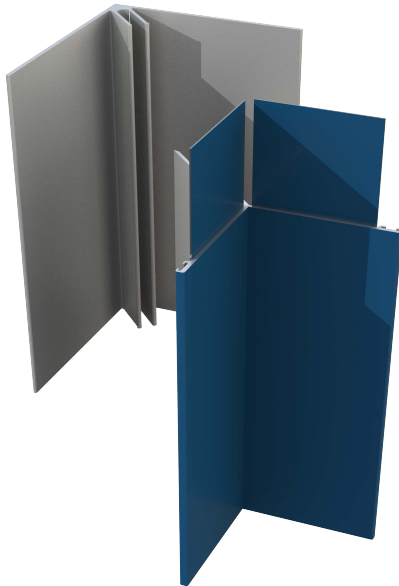

Inside Corner

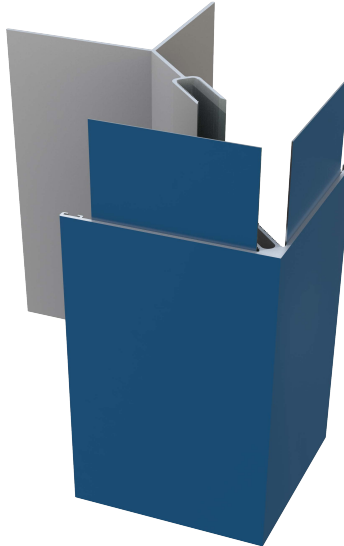

Outside Corner

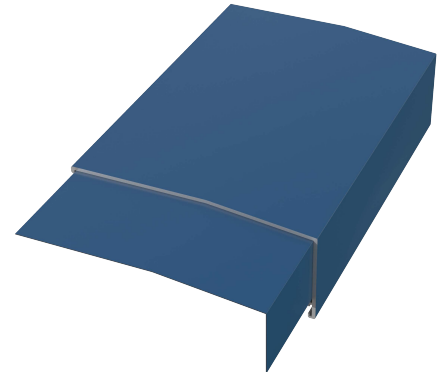

Sill

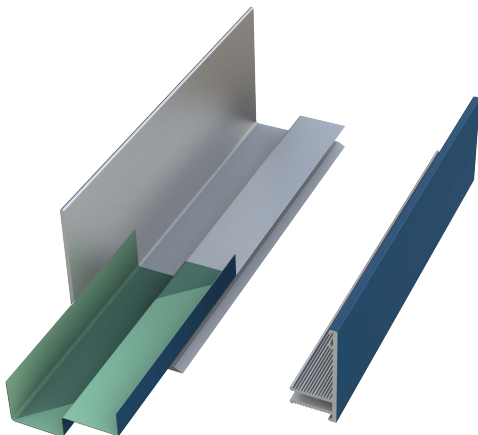

Jamb/Head

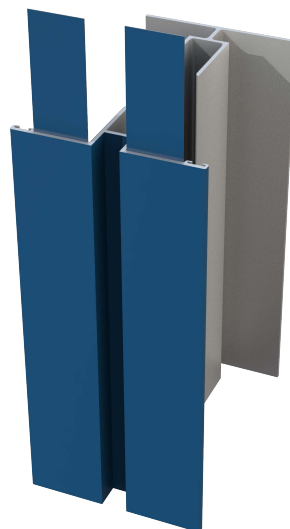

Vertical H Joint

WARNING: LEAVE 1/8" - 3/16" GAPS AT ENDJOINTS OF EXTRUSIONS TO ALLOW FOR THERMAL EXPANSION.

17. EXTRUSIONS - WINDOW ASSEMBLY

17.1 Notch interior and exterior head and sill extrusions as required.

17.2 Attach extrusions to structure with #12 pancake fasteners - see Chapter 15 Installation

Details.

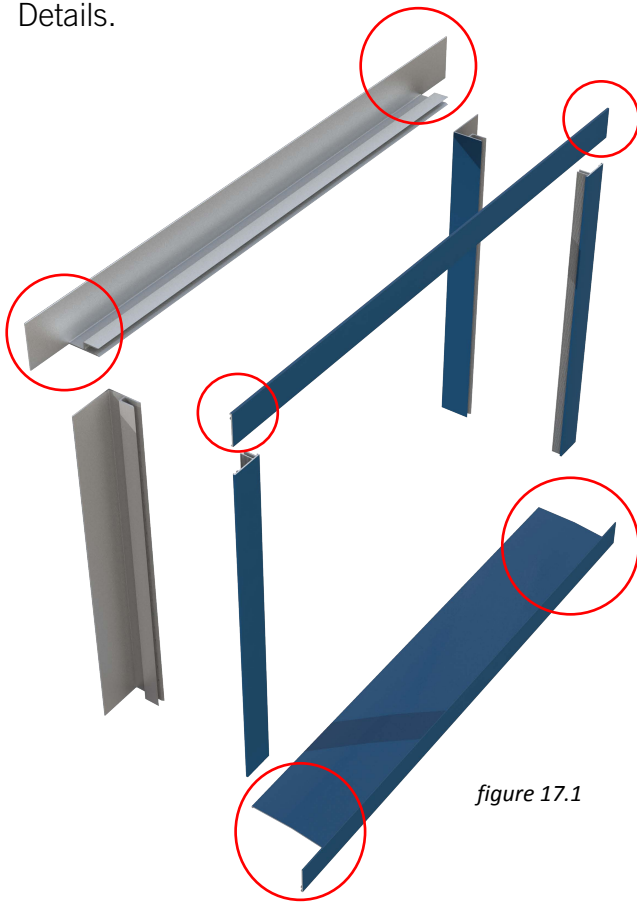

figure 17.1

17.3 Drill 3/8" weep holes less than or equal to 24" on center.

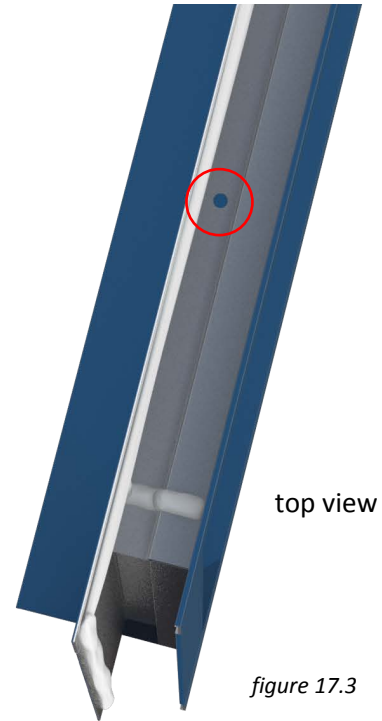

figure 17.3

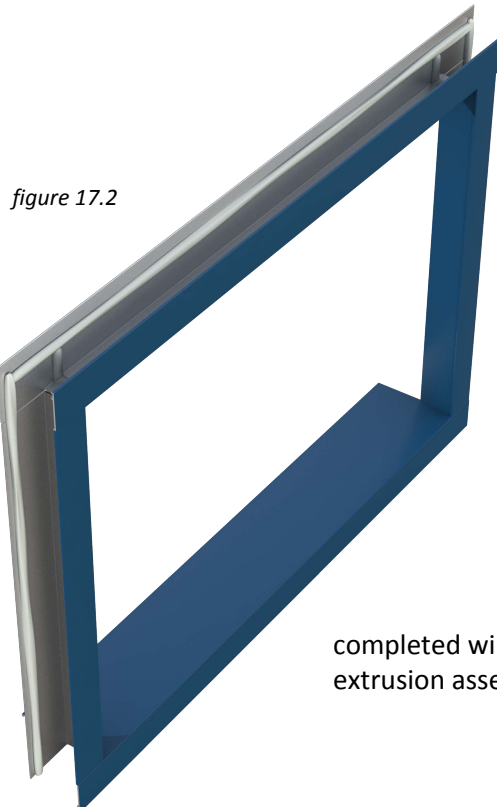

figure 17.2

WARNING: DO NOT INSTALL WINDOW WITHIN EXTRUSION AREA. WINDOW SHOULD BE FLUSH WITH STRUCTURAL LINE.

completed window
extrusion assembly

18. TOOLS, HARDWARE AND SUPPLIES

CUTTING AND BENDING TOOLS



circular saw w/carbide tip blade



panel saw



serrated knife



Dremel kit



power shears



nibbler



snips



seamer/bender



duckbills

FASTENERS, CLIPS



TEK (self-drilling, self-tapping fastener)



pancake fastener



stitch screw



B point fastener



pop rivets

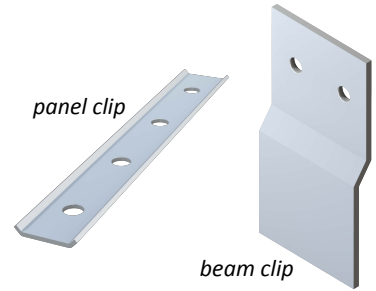

panel clip

beam clip

SEALANTS



BUTYL CAULK



Urethane CAULK



Expandable FOAM



butyl tape

MISCELLANEOUS



level



caulking gun (electric)



power drill



Phillips head bit



#2, #3 square drive bits



hex head socket set



deburring tool



scraper



tape measure



rivet tool



rivet tool (electric)



METL-SPAN

1720 LAKEPOINTE DRIVE, SUITE 101
LEWISVILLE, TX 75057

877.585.9969
INFO@METLSPAN.COM

© 2015 METL-SPAN, A DIVISION OF NCI GROUP, INC. ALL RIGHTS RESERVED.



Part No. CIWIGV-1115 11.2015