

1/4-14 x 1 1/4 LONG-LIFE
SELF-DRILLER W/WASHER
[FASTENER #1E] (2) PER ENDLAP
@ TRAPEZOIDS

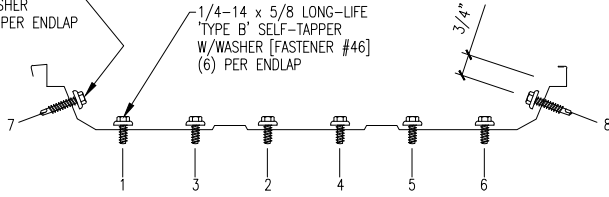

FASTENER SEQUENCE @ ENDLAP

TRI-BEAD TAPE SEALER [HW-504]
CONT. ACROSS PANEL OVER
PRE-PUNCHED HOLES

NOTE:
APPLY TRI-BEAD TAPE SEALER
OVER THE NOTCHED PORTION
OF THE MALE LEGS

LOW SLIDING CLIP
[HW-2122]

DOUBLE-LOK PANEL
(PREPUNCHED)

BEARING PLATE
[HW-7500]

12

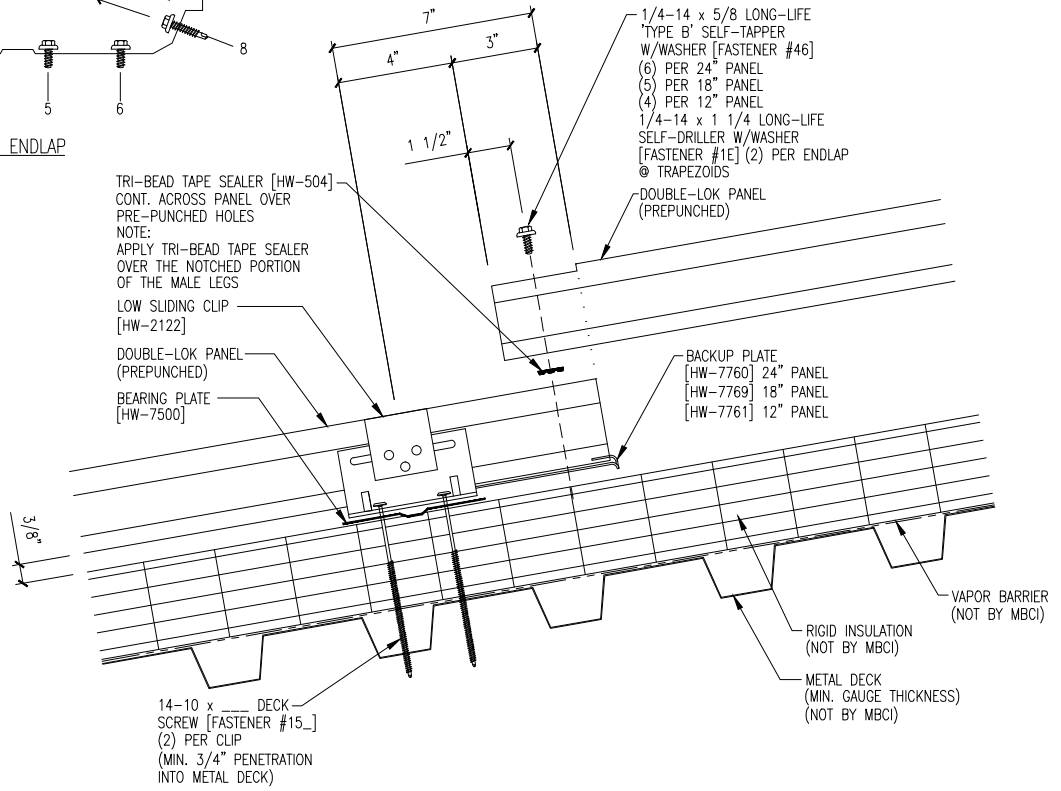

14-10 x _____ DECK
SCREW [FASTENER #15_]
(2) PER CLIP
(MIN. 3/4" PENETRATION
INTO METAL DECK)

BACKUP PLATE
[HW-7760] 24" PANEL
[HW-7769] 18" PANEL
[HW-7761] 12" PANEL

VAPOR BARRIER
(NOT BY MBCI)
RIGID INSULATION
(NOT BY MBCI)
METAL DECK
(MIN. GAUGE THICKNESS)
(NOT BY MBCI)

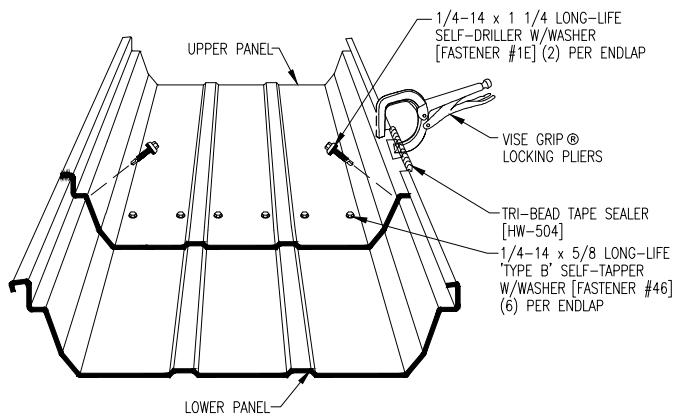

PANEL INSTALLATION SEQUENCE

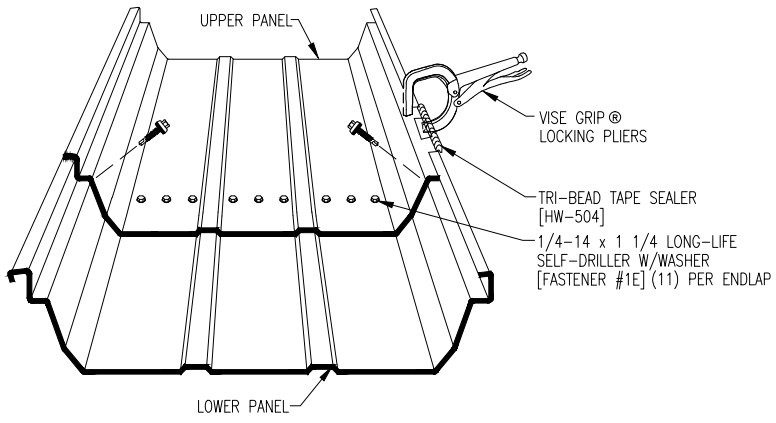
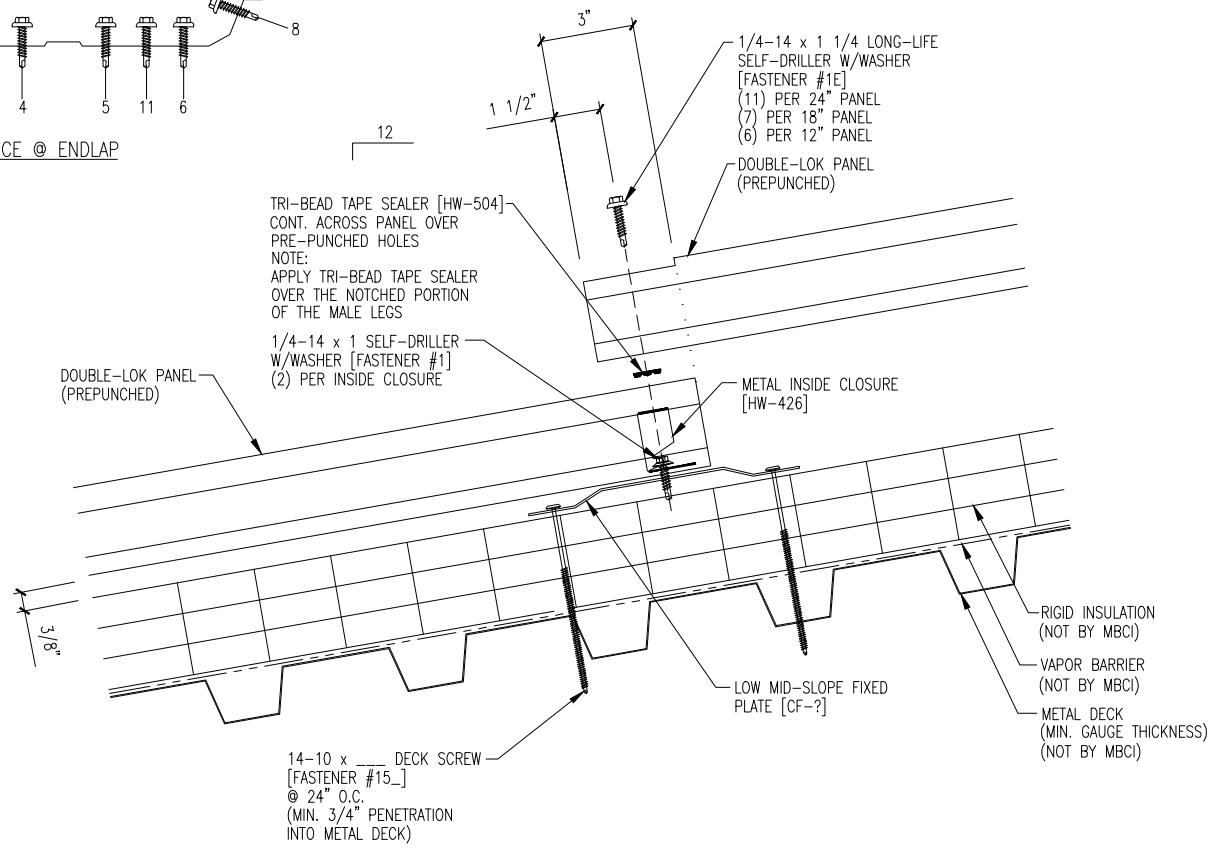
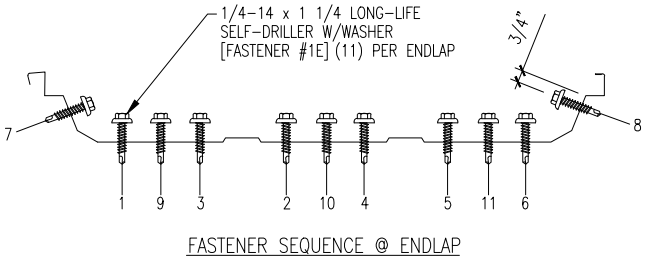

PANEL INSTALLATION SEQUENCE

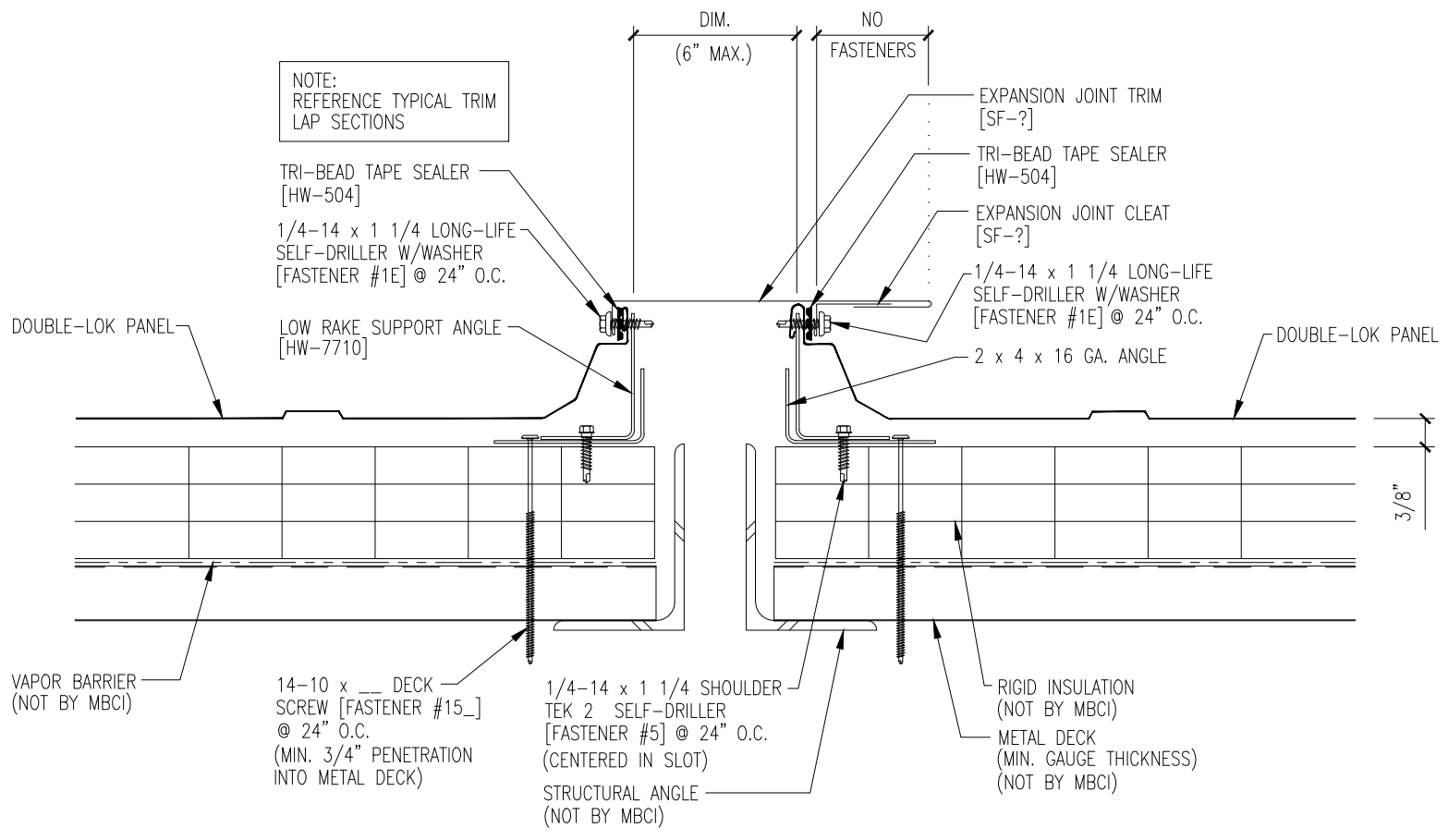

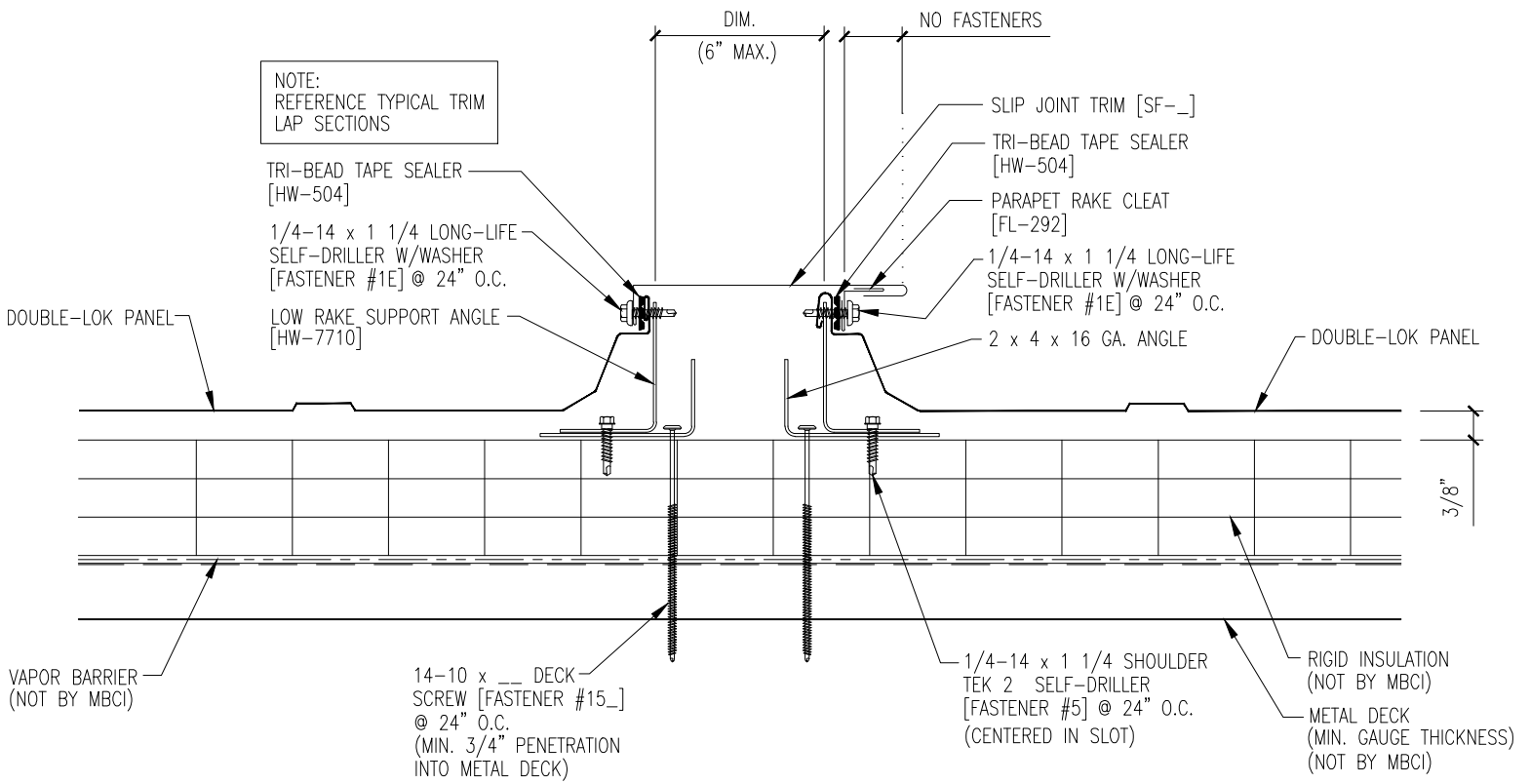

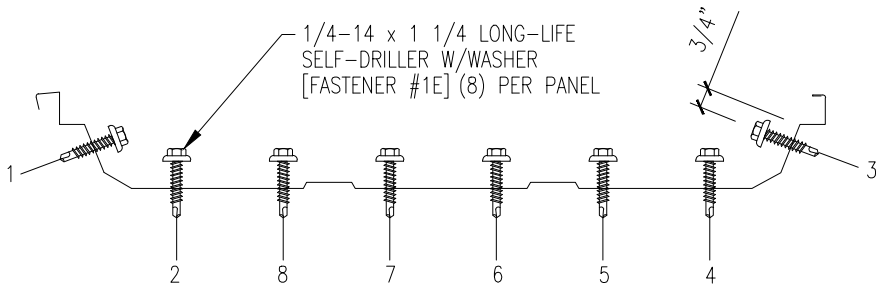

FASTENER SEQUENCE @ EAVE

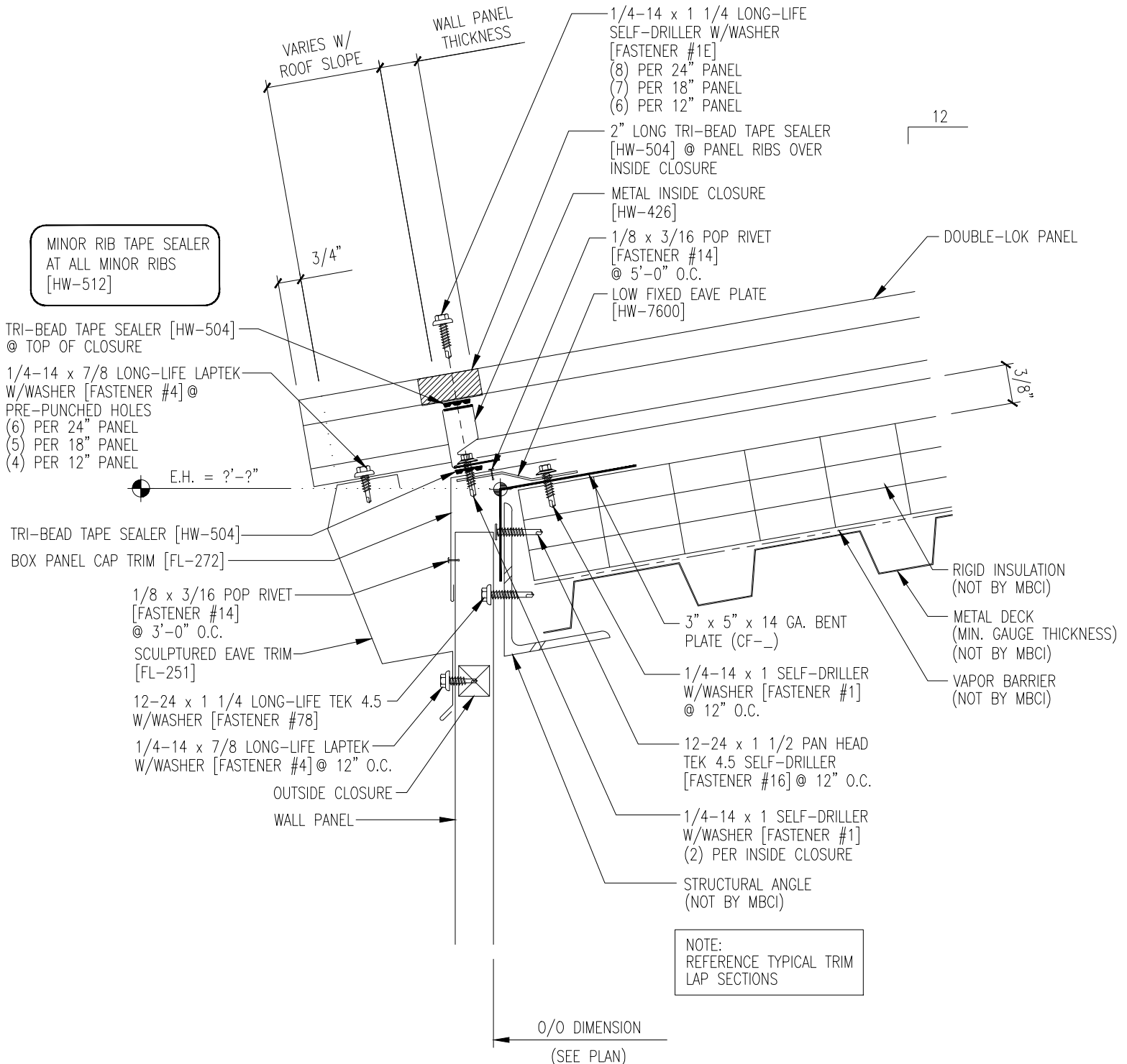

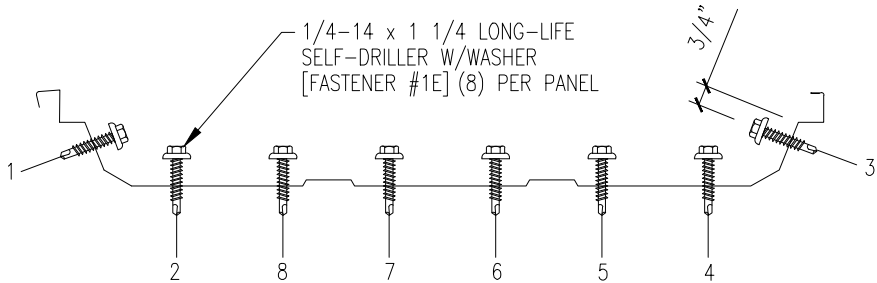

FASTENER SEQUENCE @ EAVE

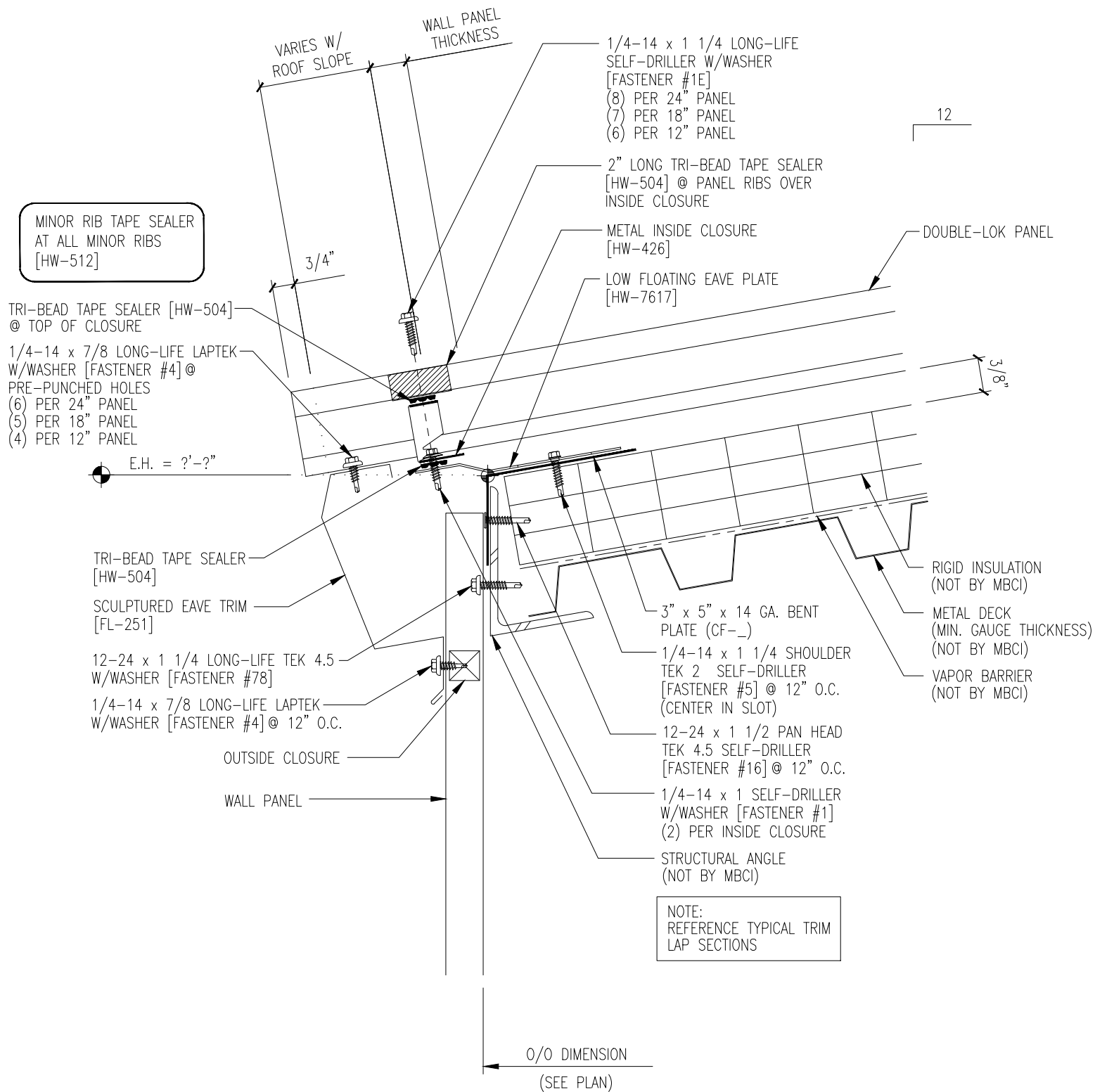

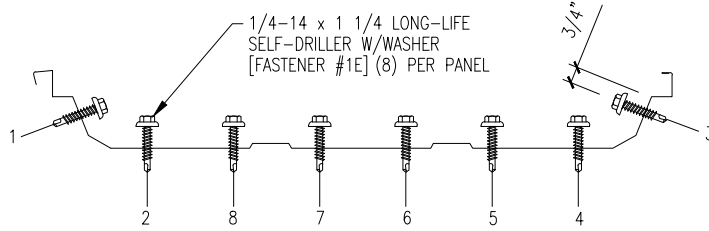

FASTENER SEQUENCE @ EAVE

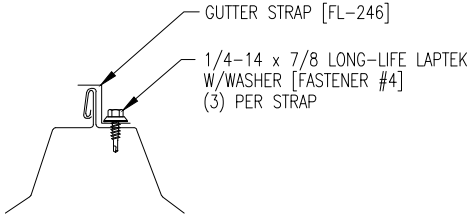

MINOR RIB TAPE SEALER AT ALL MINOR RIBS [HW-512]

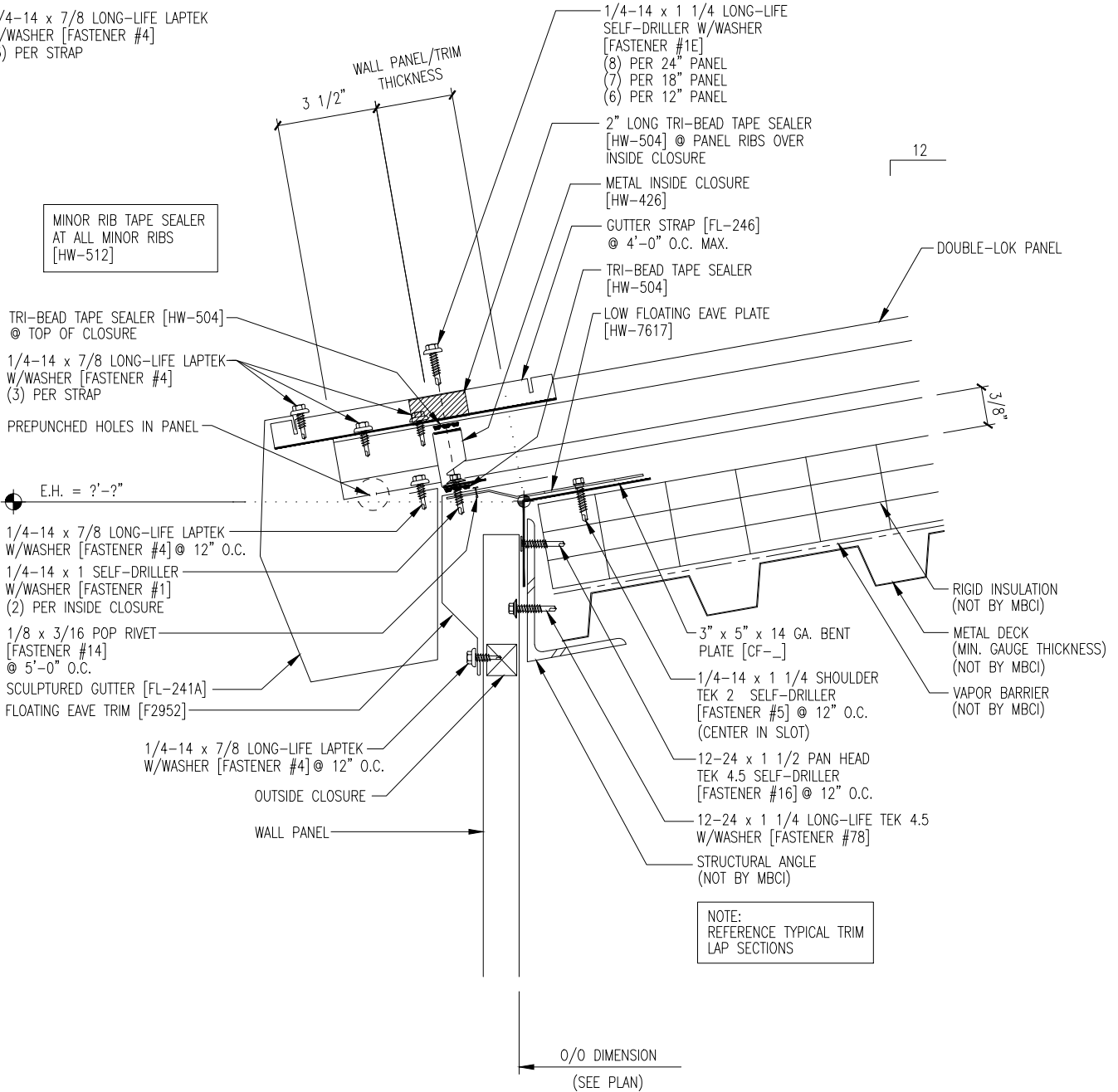

NOTE: REFERENCE TYPICAL TRIM LAP SECTIONS

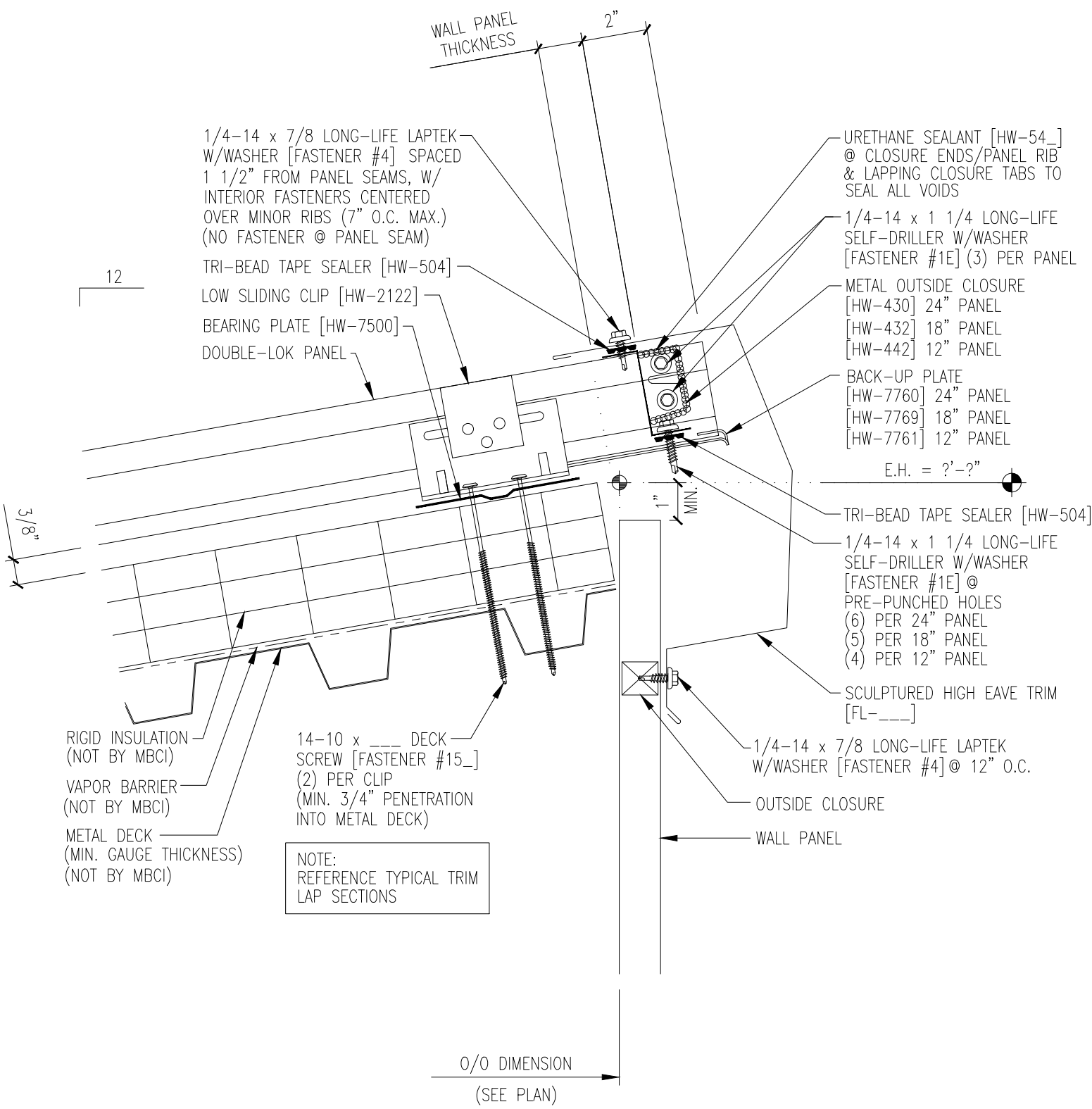

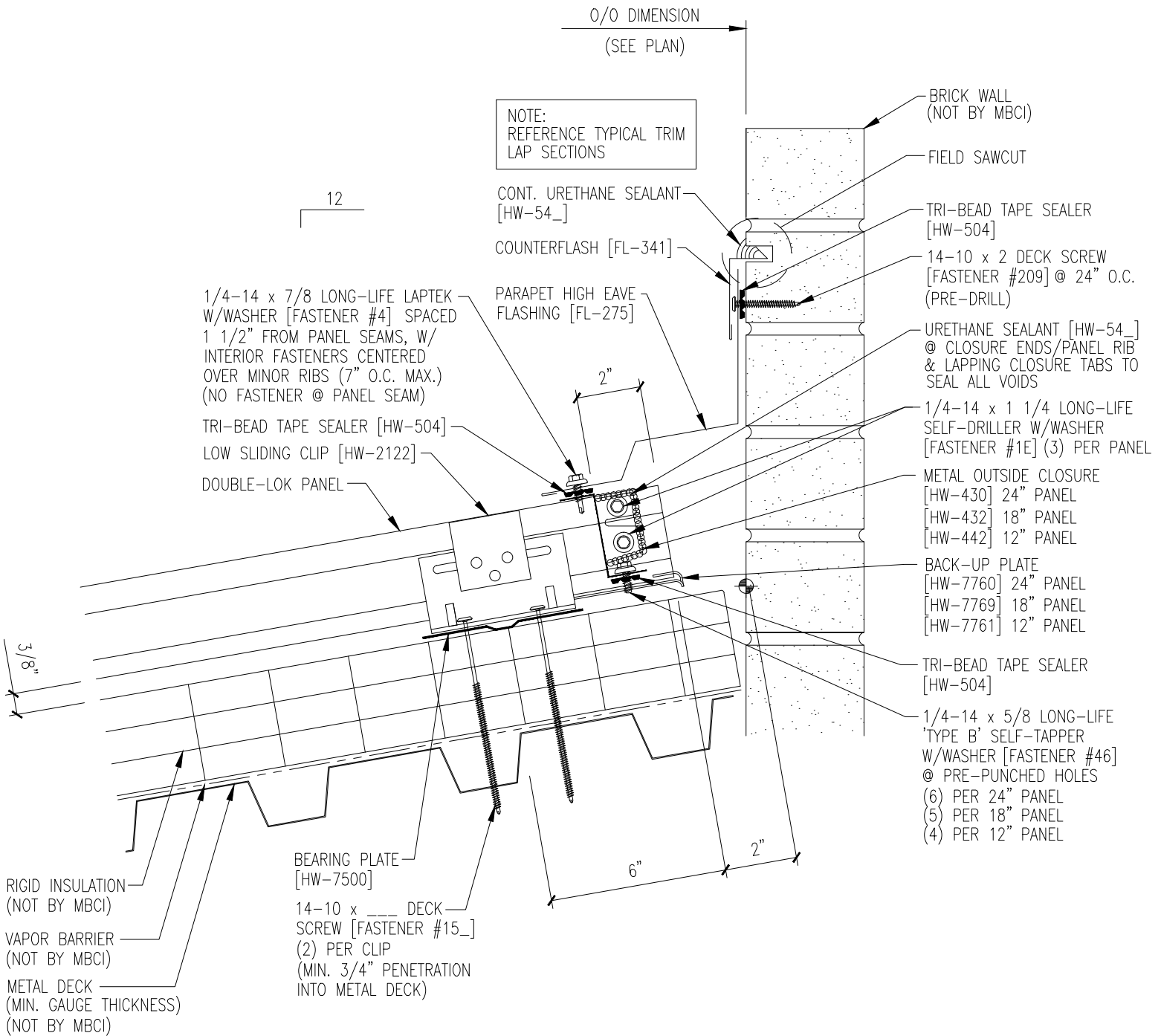

O/O DIMENSION
(SEE PLAN)

NOTE:
REFERENCE TYPICAL TRIM
LAP SECTIONS

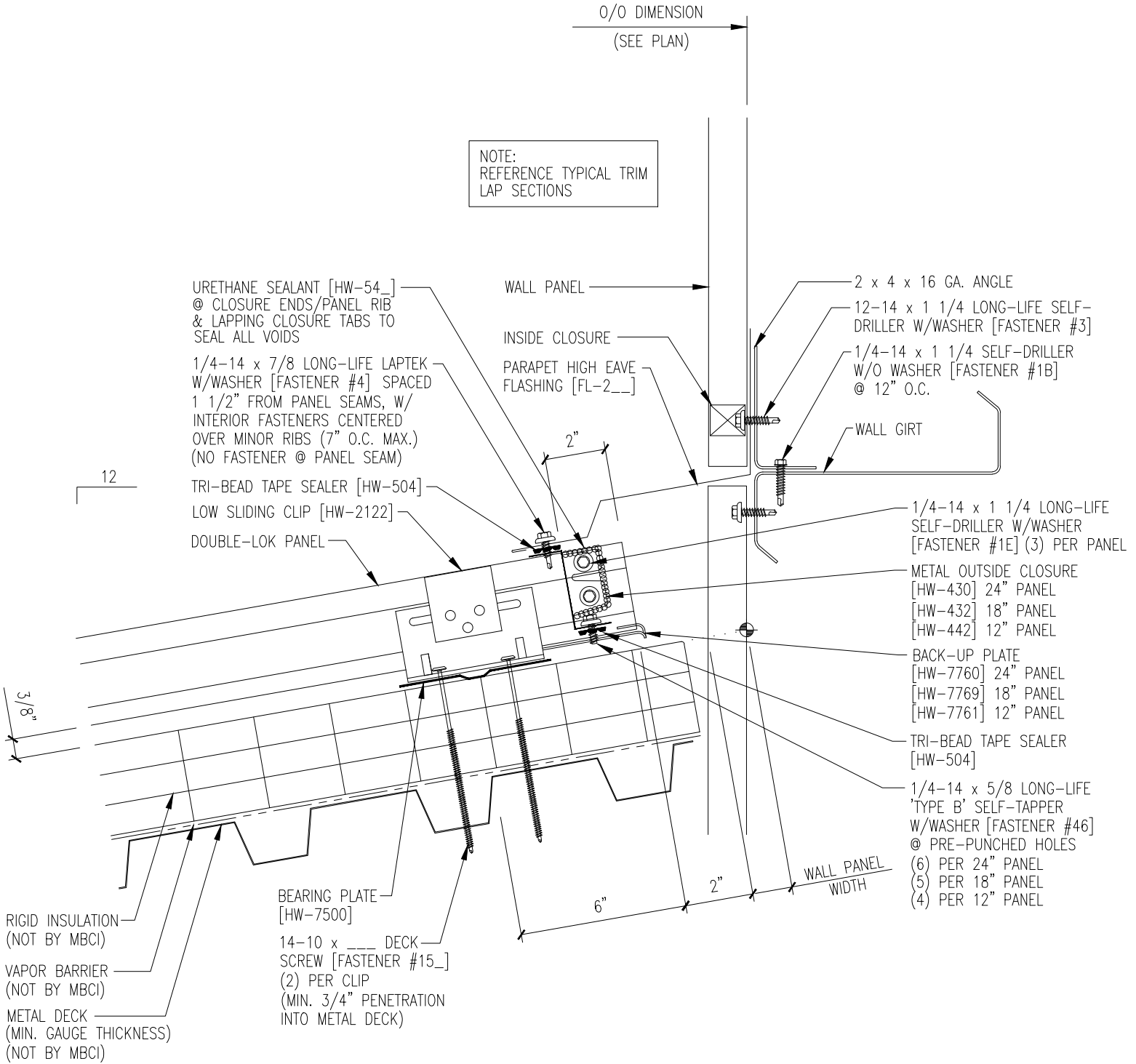

O/O DIMENSION
(SEE PLAN)

NOTE:
REFERENCE TYPICAL TRIM
LAP SECTIONS

12

CONT. URETHANE SEALANT
[HW-54_]

COUNTERFLASH [FL-341]

PARAPET HIGH EAVE
FLASHING [SF-_-]

BRICK WALL
(NOT BY MBCI)

FIELD SAWCUT

TRI-BEAD TAPE SEALER
[HW-504]

14-10 x 2 DECK SCREW
[FASTENER #209] @ 24" O.C.
(PRE-DRILL)

PERFORATED VENT DRIP [FL-254]

URETHANE SEALANT [HW-54_] @ CLOSURE ENDS/PANEL RIB & LAPPING CLOSURE TABS TO SEAL ALL VOIDS

1/4-14 x 1 1/4 LONG-LIFE SELF-DRILLER W/WASHER [FASTENER #1E] (3) PER PANEL

METAL OUTSIDE CLOSURE [HW-430] 24" PANEL [HW-432] 18" PANEL [HW-442] 12" PANEL

BACK-UP PLATE [HW-7760] 24" PANEL [HW-7769] 18" PANEL [HW-7761] 12" PANEL

TRI-BEAD TAPE SEALER [HW-504]

1/4-14 x 5/8 LONG-LIFE 'TYPE B' SELF-TAPPER W/WASHER [FASTENER #46] @ PRE-PUNCHED HOLES (6) PER 24" PANEL (5) PER 18" PANEL (4) PER 12" PANEL

1/4-14 x 7/8 LONG-LIFE LAPTEK W/WASHER [FASTENER #4] SPACED 1 1/2" FROM PANEL SEAMS, W/ INTERIOR FASTENERS CENTERED OVER MINOR RIBS (7" O.C. MAX.) (NO FASTENER @ PANEL SEAM)

TRI-BEAD TAPE SEALER [HW-504]

1/4-14 x 7/8 LONG-LIFE LAPTEK W/WASHER [FASTENER #4] @ 6" O.C.

LOW SLIDING CLIP [HW-2122]

BEARING PLATE [HW-7500]

DOUBLE-LOK PANEL

3/8"

RIGID INSULATION (NOT BY MBCI)

METAL DECK (MIN. GAUGE THICKNESS) (NOT BY MBCI)

VAPOR BARRIER (NOT BY MBCI)

14-10 x ____ DECK SCREW [FASTENER #15_] (2) PER CLIP (MIN. 3/4" PENETRATION INTO METAL DECK)

2"

6"

2"

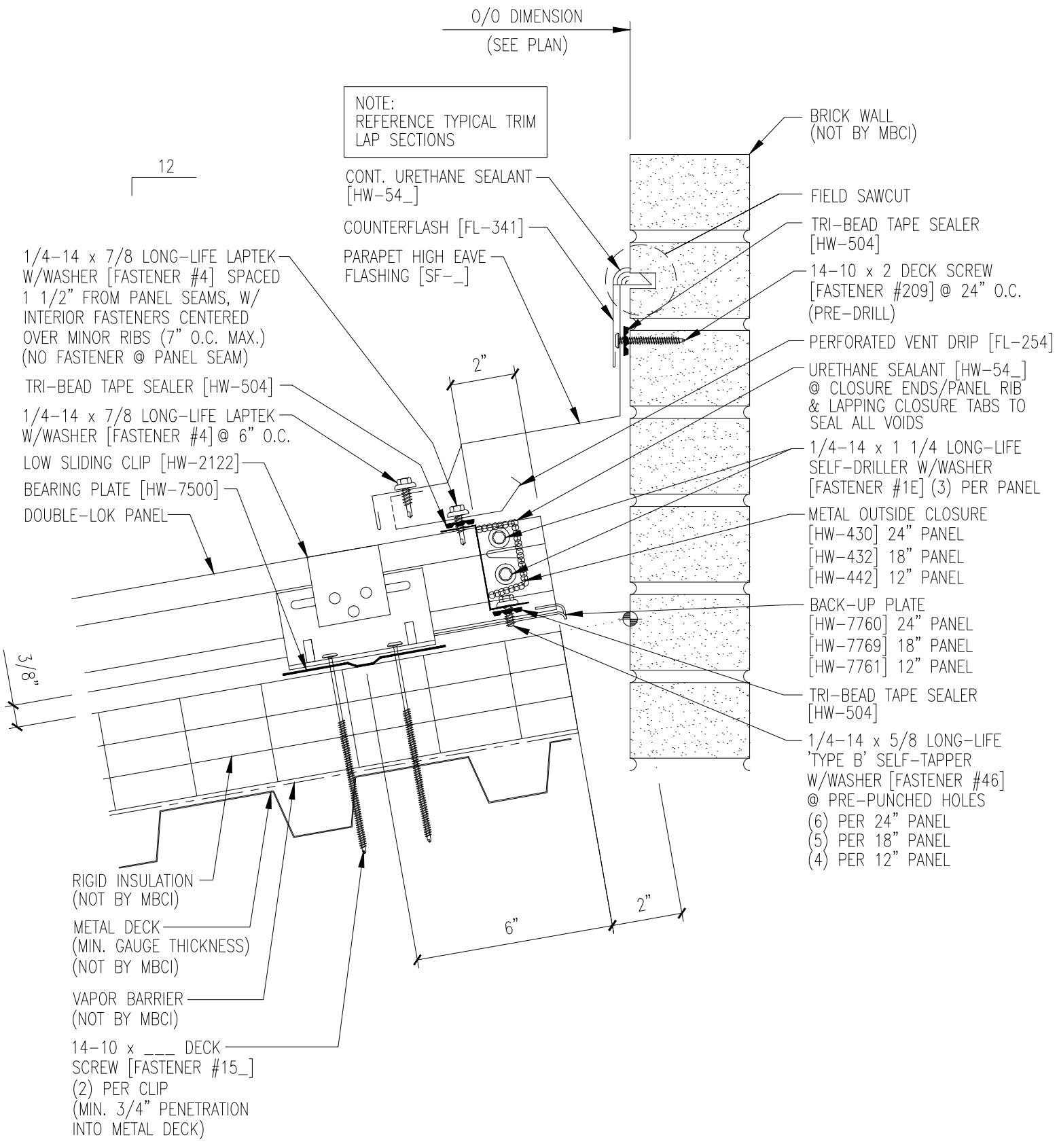

O/O DIMENSION
(SEE PLAN)

NOTE:
REFERENCE TYPICAL TRIM
LAP SECTIONS

12

1/4-14 x 7/8 LONG-LIFE LAPTEK
W/WASHER [FASTENER #4] SPACED
1 1/2" FROM PANEL SEAMS, W/
INTERIOR FASTENERS CENTERED
OVER MINOR RIBS (7" O.C. MAX.)
(NO FASTENER @ PANEL SEAM)

TRI-BEAD TAPE SEALER [HW-504]

1/4-14 x 7/8 LONG-LIFE LAPTEK
W/WASHER [FASTENER #4] @ 6" O.C.

LOW SLIDING CLIP [HW-2122]

BEARING PLATE [HW-7500]

DOUBLE-LOK PANEL

CONT. URETHANE SEALANT
[HW-54_]

COUNTERFLASH [FL-341]

PARAPET HIGH EAVE
FLASHING [SF-_]

BRICK WALL
(NOT BY MBCI)

FIELD SAWCUT

TRI-BEAD TAPE SEALER
[HW-504]

14-10 x 2 DECK SCREW
[FASTENER #209] @ 24" O.C.
(PRE-DRILL)

METAL VENT MATERIAL [HW-525]

URETHANE SEALANT [HW-54_] @
CLOSURE ENDS/PANEL RIB &
LAPPING CLOSURE TABS TO
SEAL ALL VOIDS

1/4-14 x 1 1/4 LONG-LIFE
SELF-DRILLER W/WASHER
[FASTENER #1E] (3) PER PANEL

METAL OUTSIDE CLOSURE
[HW-430] 24" PANEL
[HW-432] 18" PANEL
[HW-442] 12" PANEL

BACK-UP PLATE
[HW-7760] 24" PANEL
[HW-7769] 18" PANEL
[HW-7761] 12" PANEL

TRI-BEAD TAPE SEALER
[HW-504]

1/4-14 x 5/8 LONG-LIFE
'TYPE B' SELF-TAPPER
W/WASHER [FASTENER #46]
@ PRE-PUNCHED HOLES
(6) PER 24" PANEL
(5) PER 18" PANEL
(4) PER 12" PANEL

3/8"

2"

6"

2"

RIGID INSULATION
(NOT BY MBCI)

METAL DECK
(MIN. GAUGE THICKNESS)
(NOT BY MBCI)

VAPOR BARRIER
(NOT BY MBCI)

14-10 x ___ DECK
SCREW [FASTENER #15_] (2)
PER CLIP
(MIN. 3/4" PENETRATION
INTO METAL DECK)

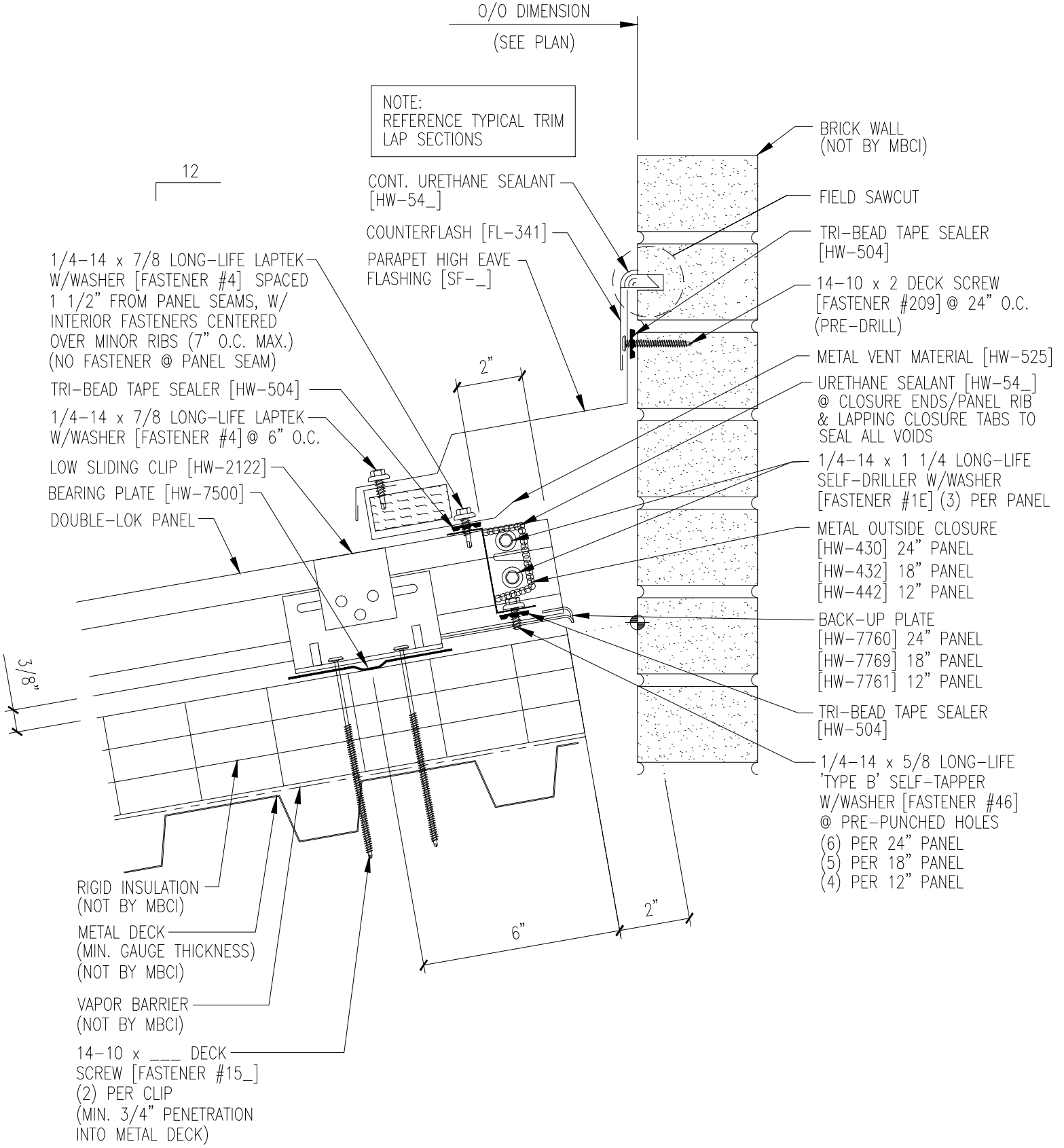

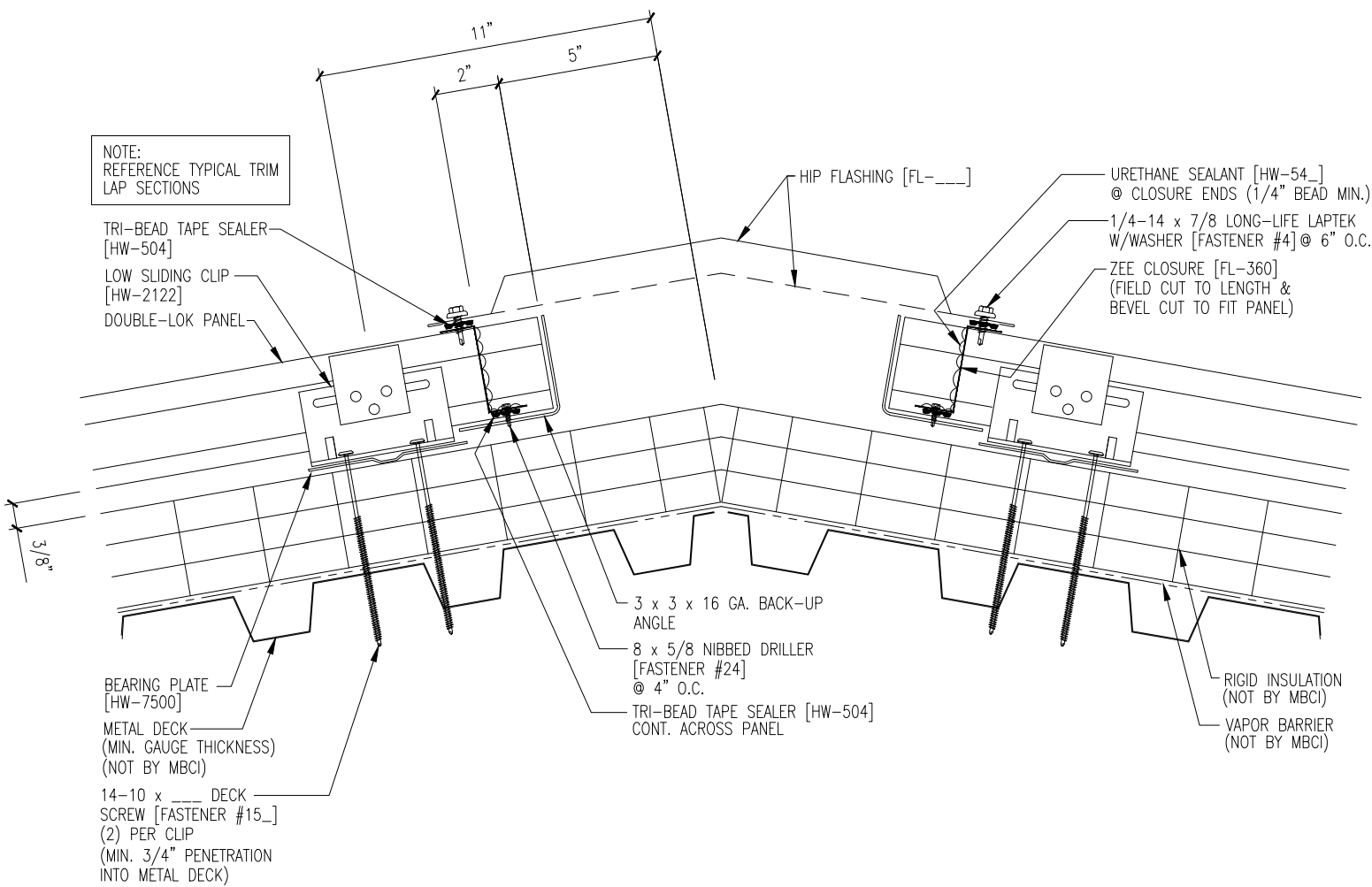

12

12

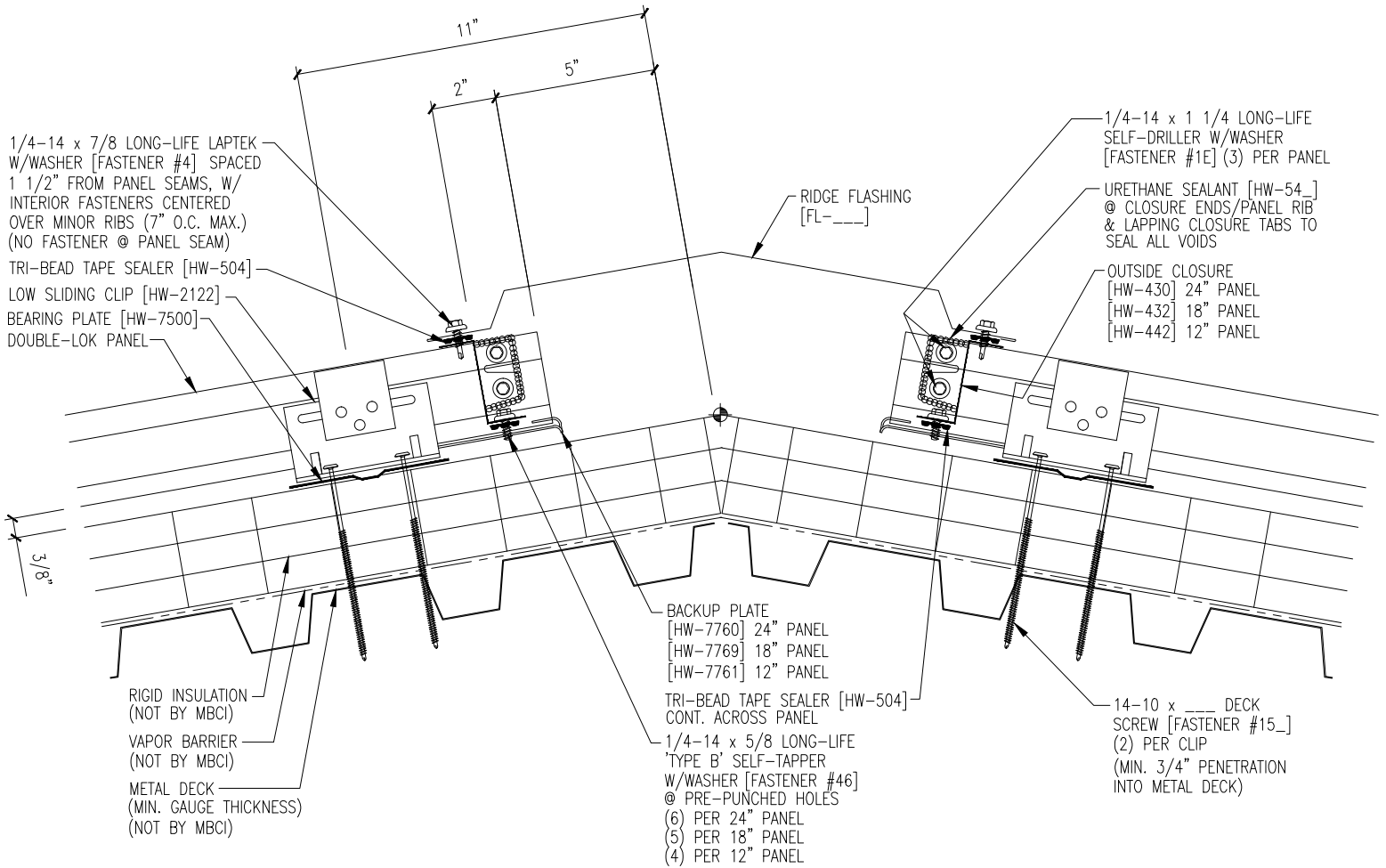

NOTE:
REFERENCE TYPICAL TRIM
LAP SECTIONS

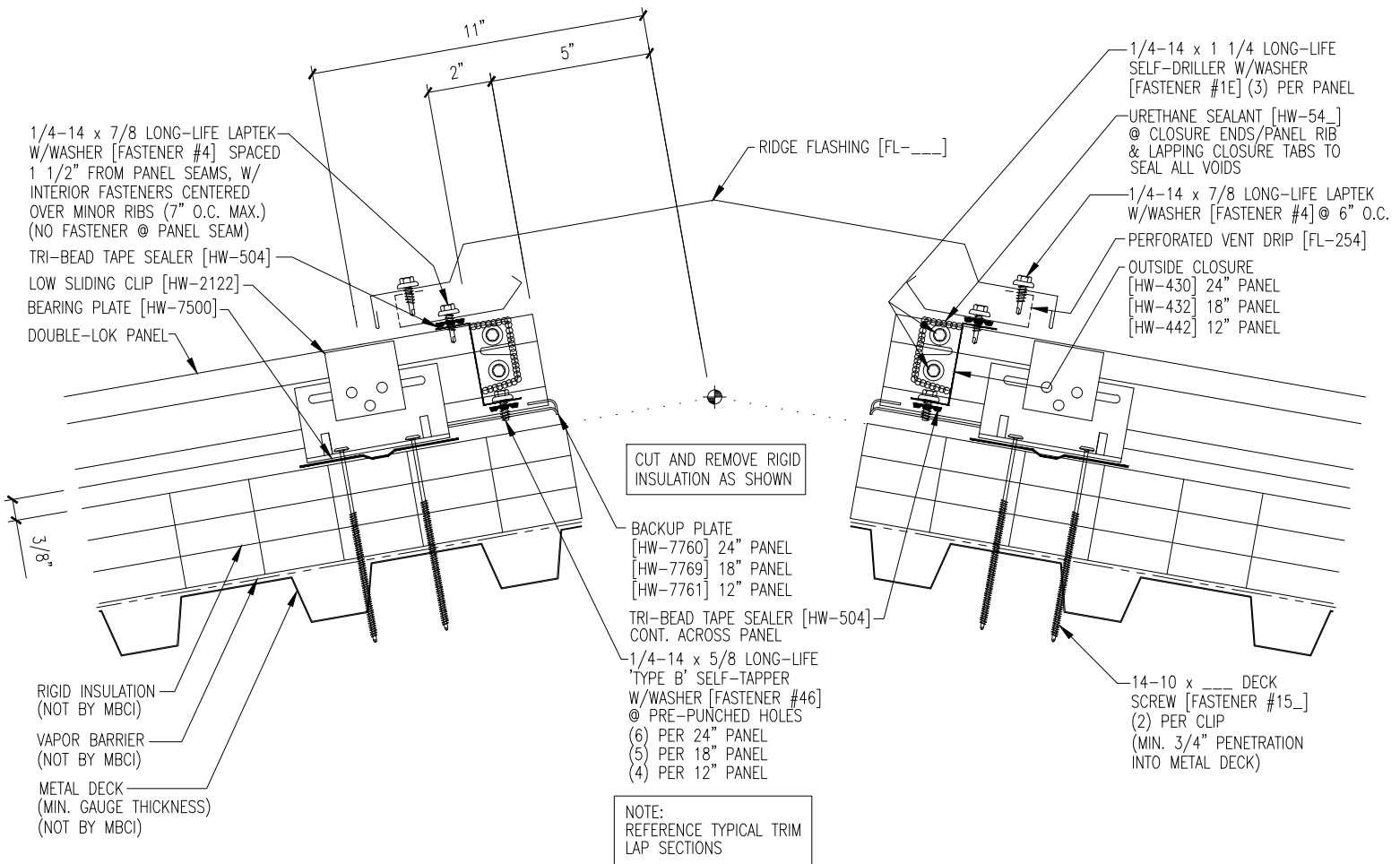

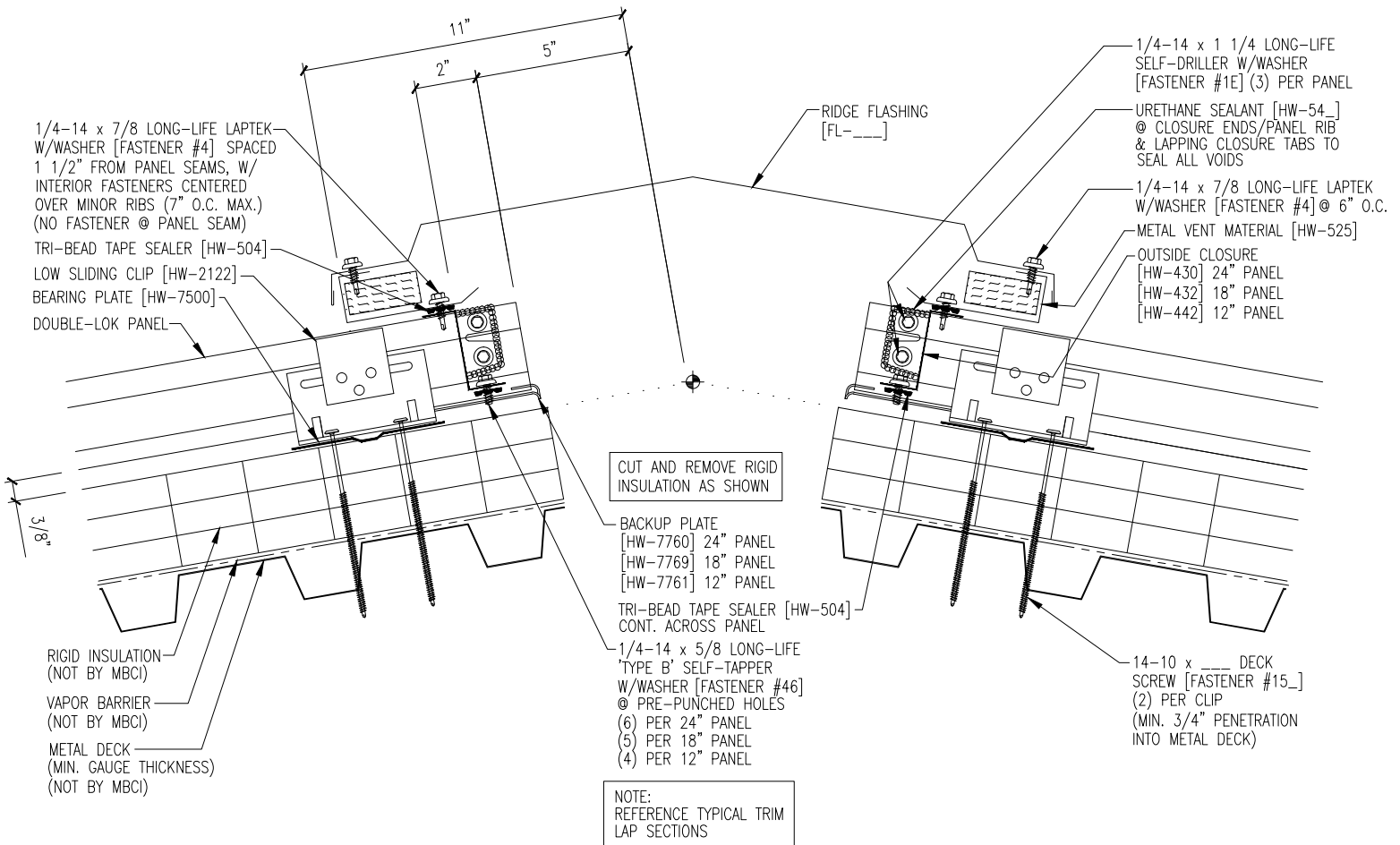

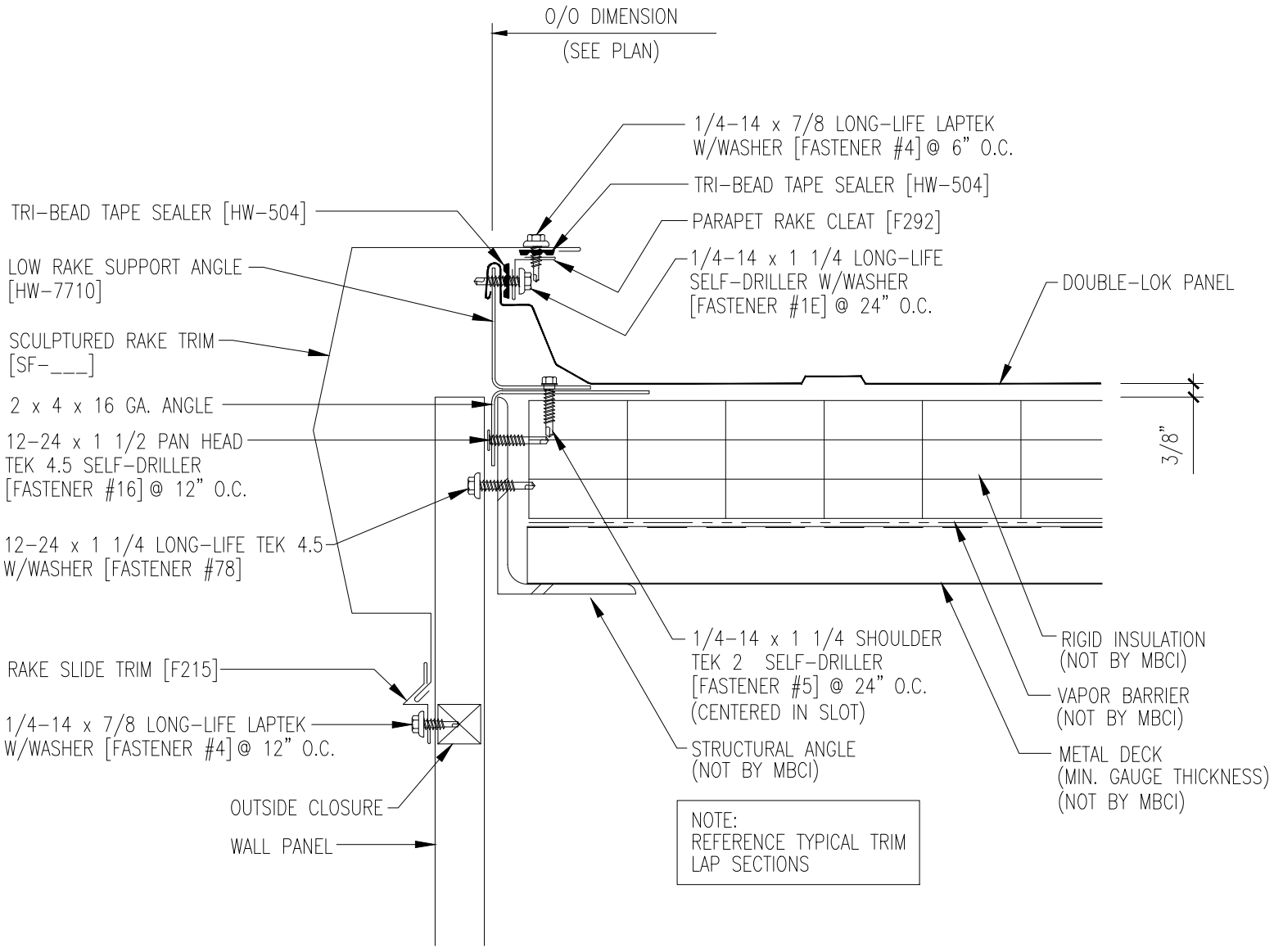

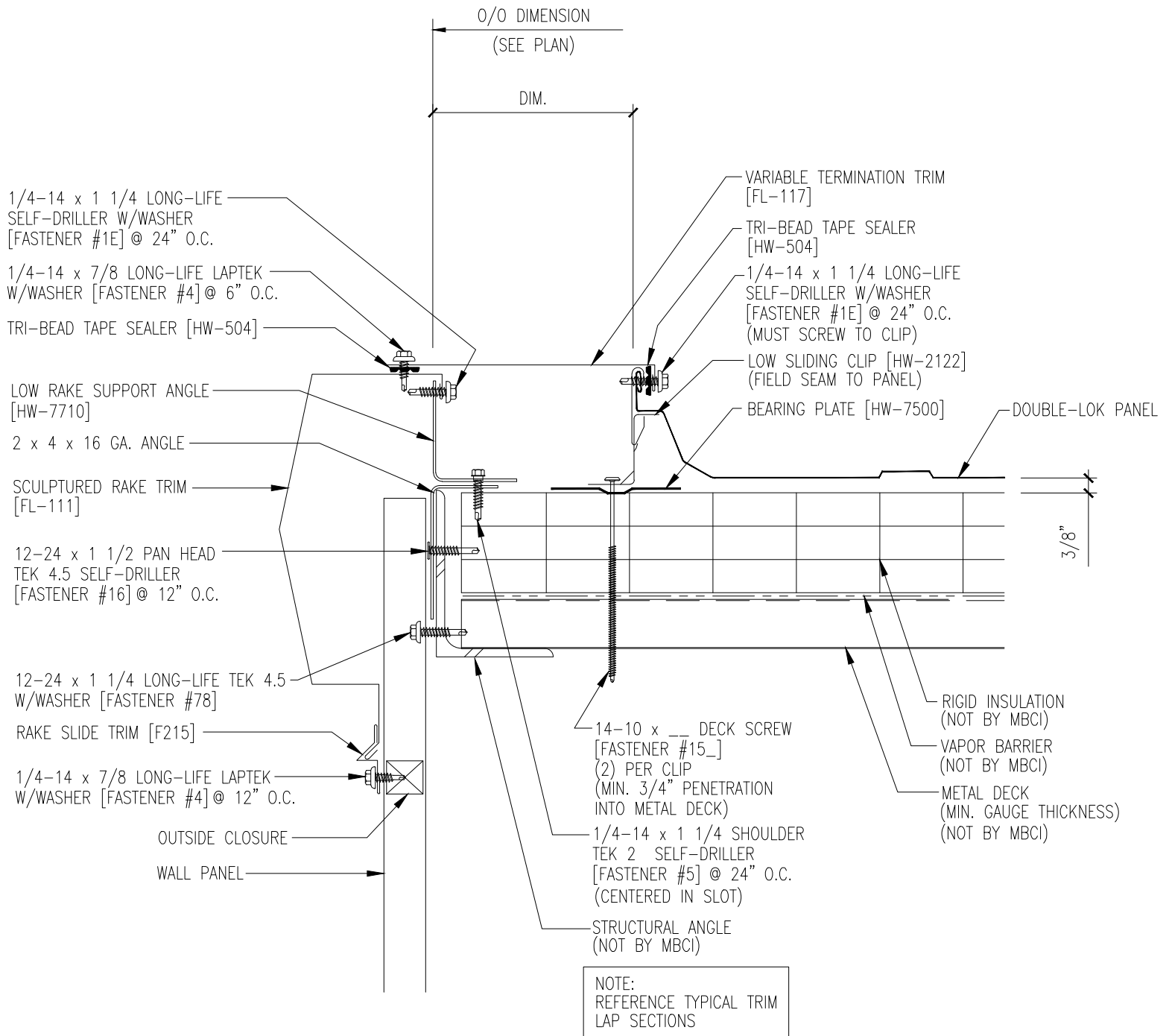

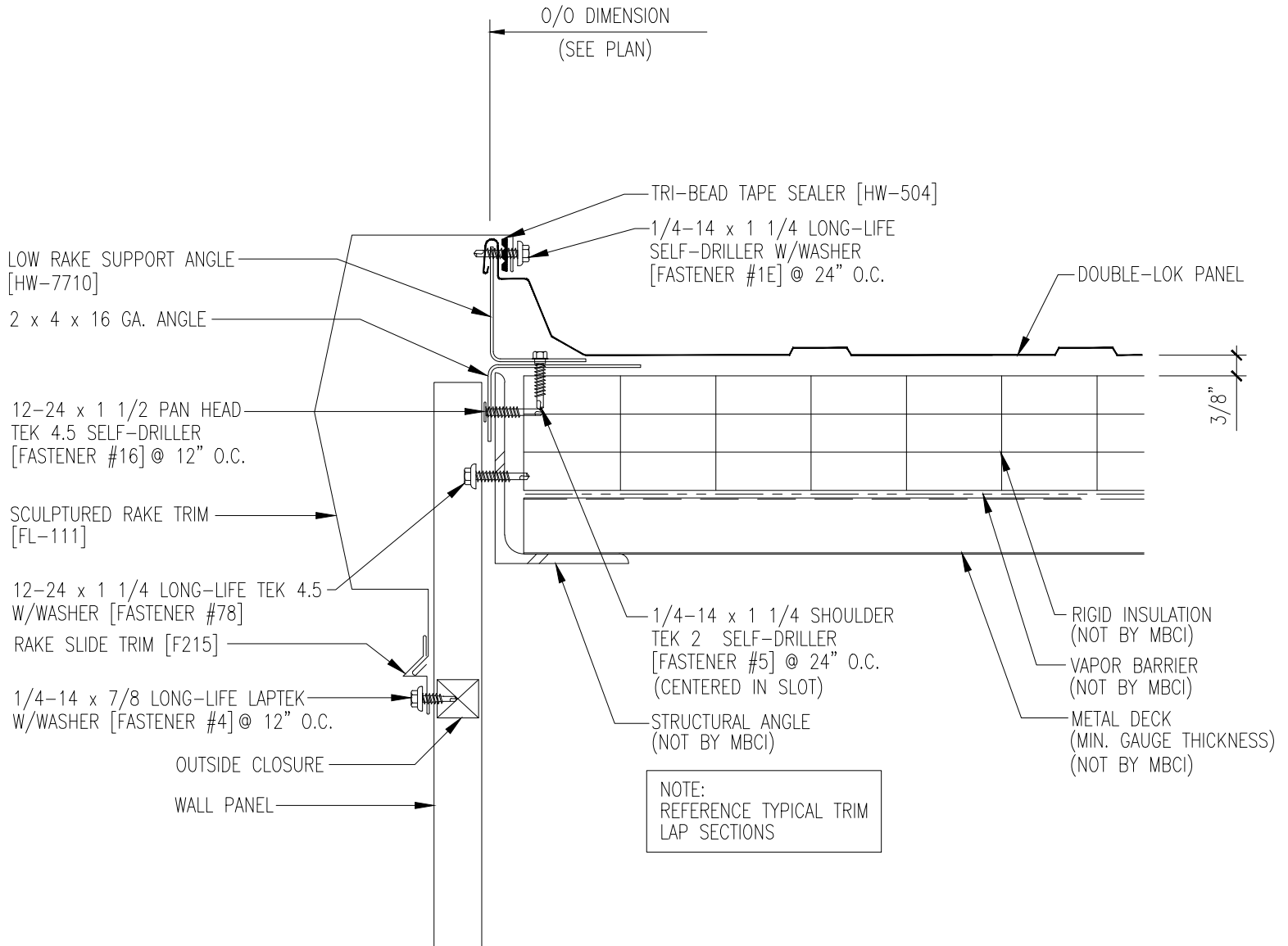

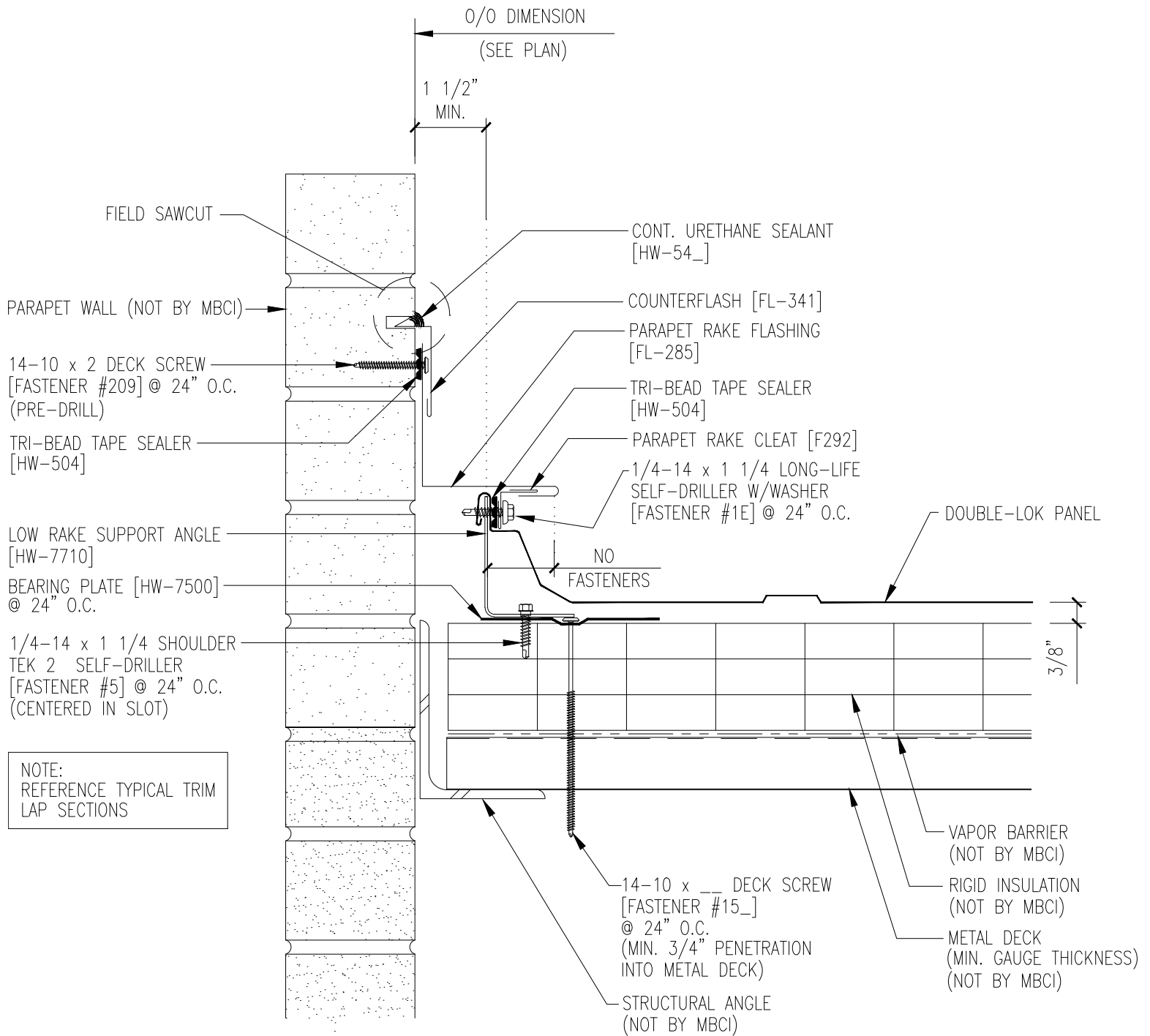

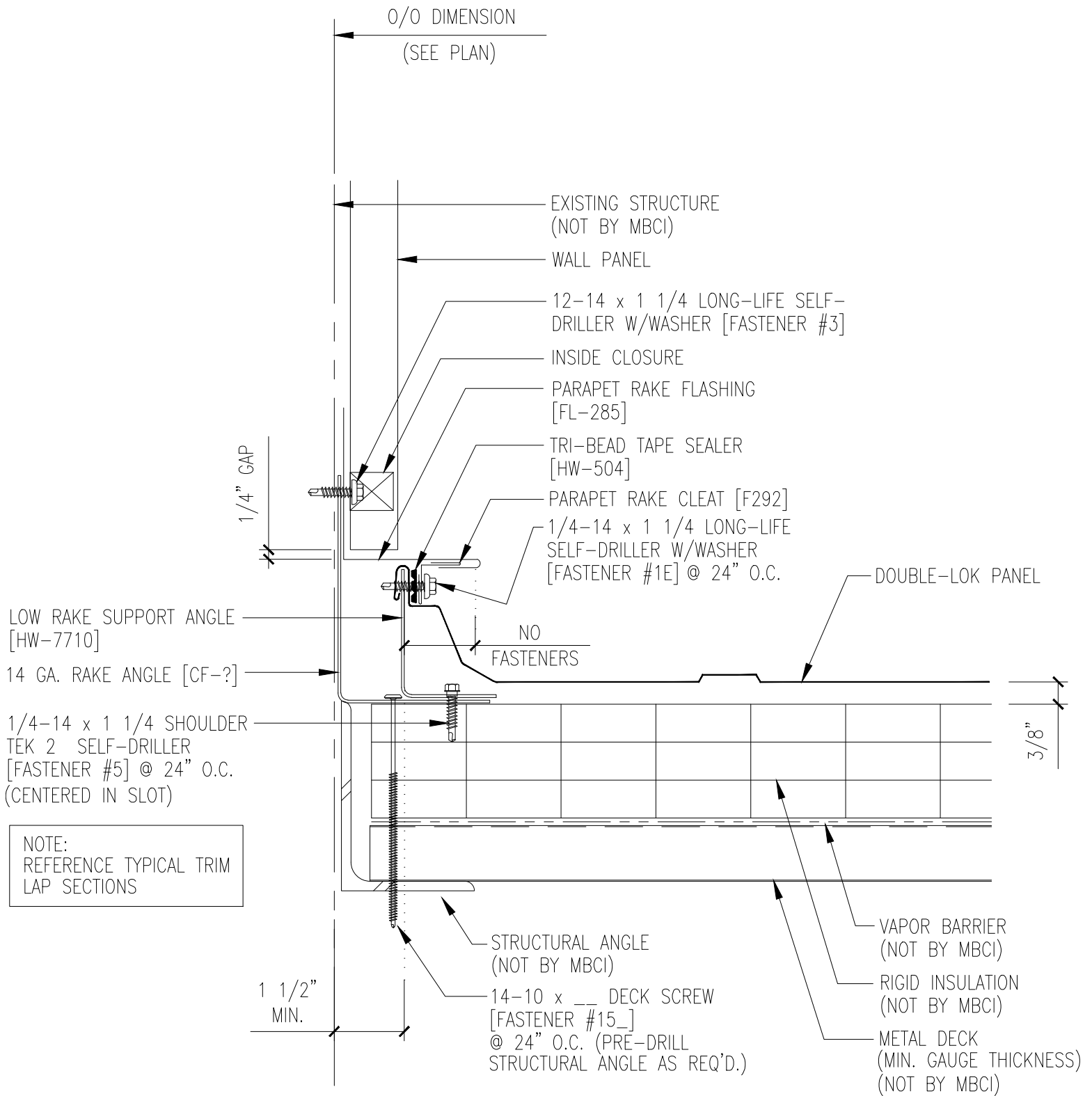

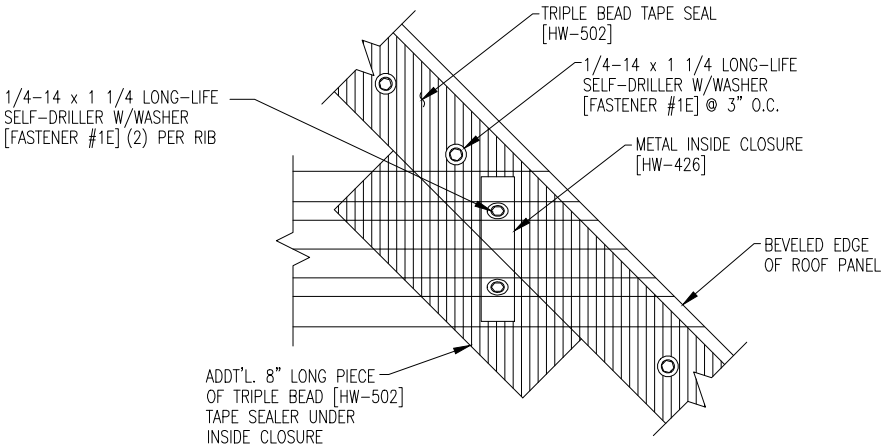
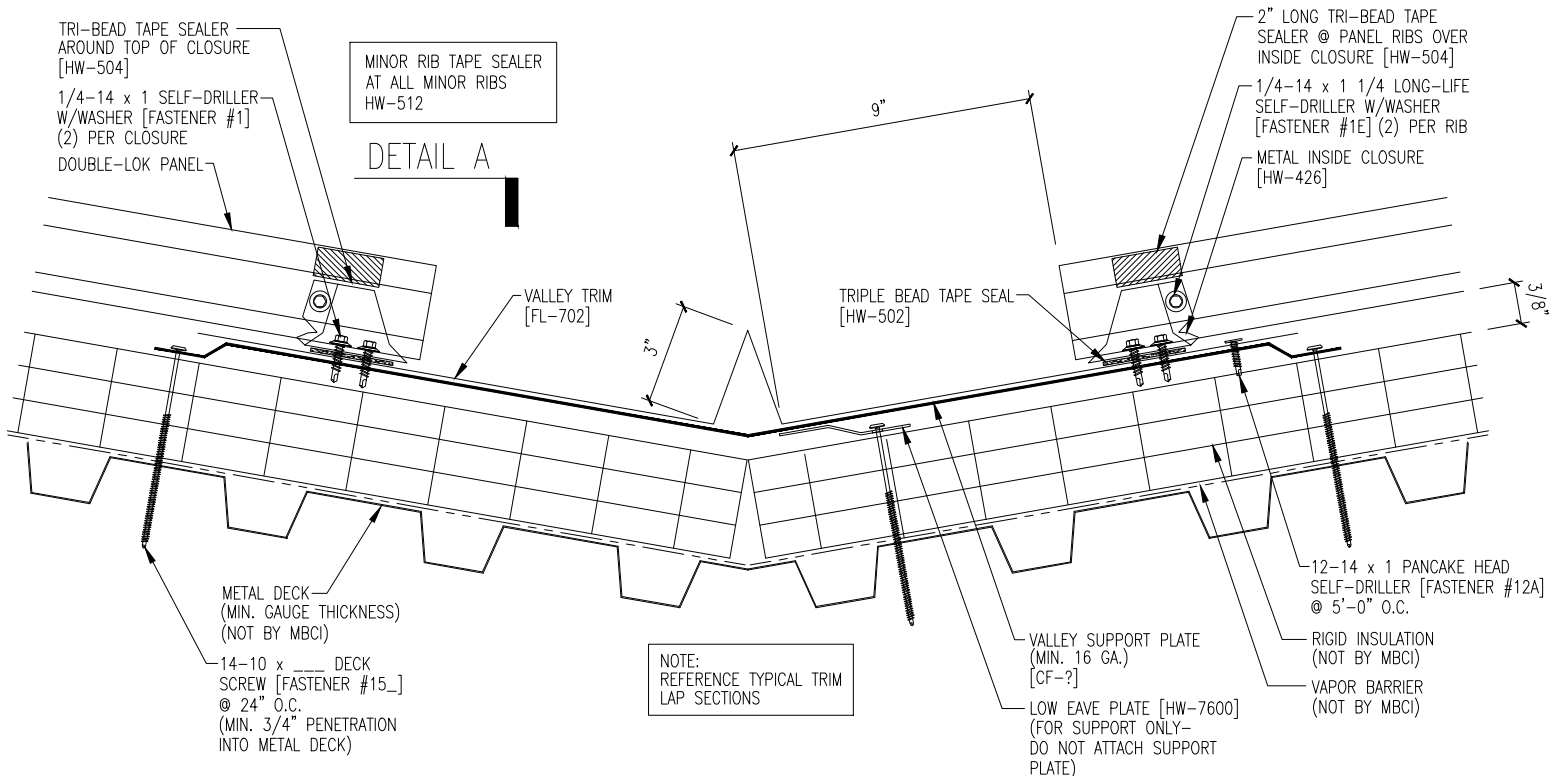

DETAIL "A"

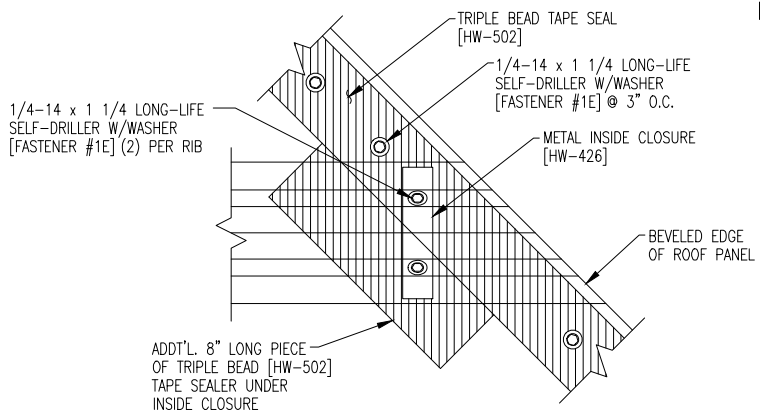
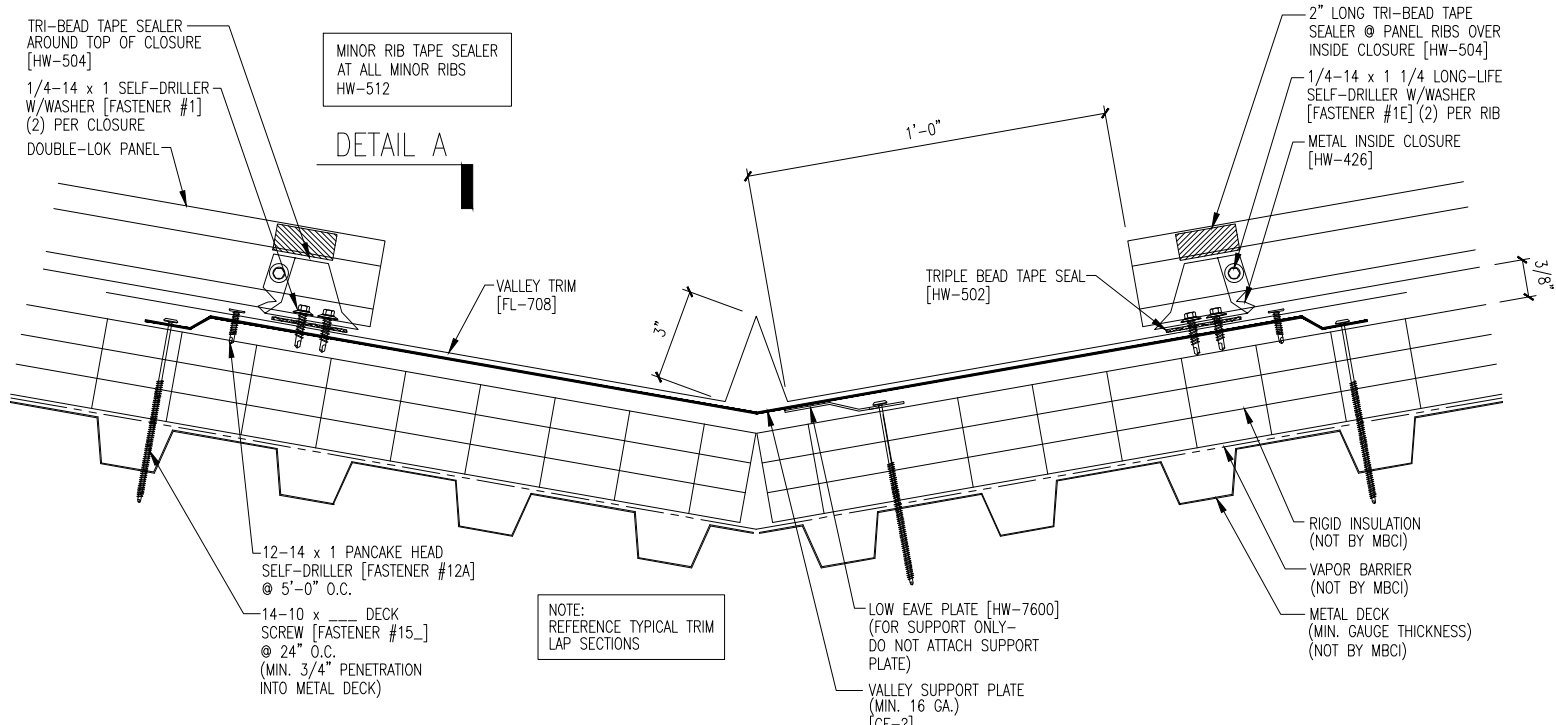

DETAIL "A"