

LS-36™
Insulated Metal Roof and Wall Panel

INSTALLATION GUIDE



IMPORTANT NOTICE

READ THIS MANUAL COMPLETELY PRIOR TO BEGINNING THE INSTALLATION OF THE LS-36™ INSULATED METAL ROOF & WALL PANEL SYSTEM. METL-SPAN® DETAILS MUST BE FOLLOWED AS A MINIMUM TO ENSURE APPROPRIATE WARRANTIES WILL BE ISSUED.

IF THERE IS CONFLICT BETWEEN PROJECT ERECTION DRAWINGS PROVIDED OR APPROVED BY METL-SPAN AND DETAILS IN THIS MANUAL, PROJECT ERECTION DRAWINGS WILL TAKE PRECEDENCE.

THIS MANUAL IS NOT TO BE USED FOR COOLER/FREEZER APPLICATIONS.

IT IS THE RESPONSIBILITY OF THE ERECTOR TO INSTALL THE LS-36™ INSULATED METAL ROOF & WALL PANEL USING SAFE CONSTRUCTION PRACTICES THAT ARE IN COMPLIANCE WITH OSHA REGULATIONS. THE MANUFACTURER IS NOT RESPONSIBLE FOR THE PERFORMANCE OF THIS ROOF/WALL SYSTEM IF IT IS NOT INSTALLED IN ACCORDANCE WITH THE INSTRUCTIONS SHOWN IN THIS MANUAL. DEVIATIONS FROM THESE INSTRUCTIONS AND DETAILS MUST BE APPROVED IN WRITING BY THE MANUFACTURER.

ALWAYS INSPECT EACH AND EVERY PANEL AND ALL ACCESSORIES BEFORE INSTALLATION. NEVER INSTALL ANY PRODUCT IF ITS QUALITY IS IN QUESTION. NOTIFY METL-SPAN IMMEDIATELY IF ANY PRODUCT IS BELIEVED TO BE OUT OF TOLERANCE, SPECIFICATION OR HAS BEEN DAMAGED DURING SHIPMENT.

Notes:

Diaphragm capabilities and purlin stability are not provided by Metl-Span LS-36™ Insulated Metal Panel roof system. Therefore, other bracing may be required.

Descriptions and specifications contained herein were in effect at the time this publication was approved for printing. In a continuing effort to refine and improve products, Metl-Span reserves the right to discontinue products at any time or change specifications and/or designs without incurring obligation. **To insure you have the latest information available, please inquire or visit our website at www.metlspan.com.** Application details are for illustration purposes only and may not be appropriate for all environmental conditions, building designs, or panel profiles. Projects should be engineered to conform to applicable building codes, regulations, and accepted industry practices.

For complete performance specifications, product limitations and disclaimers, please consult Metl-Span's Paint and Galvalume Plus® warranties. Upon receipt of payment in full, these warranties are available upon request for all painted or Galvalume Plus®, prime products.

Clarification concerning the installation of LS-36™ panels should be directed to the Metl-Span Technical Services Dept. Contact the Metl-Span office:

1720 Lakepointe Drive, Suite #101
Lewisville, Texas 75057
TEL: (972) 221-6656
FAX: (972) 436-7028
WEB: metlspan.com

TABLE OF CONTENTS

GENERAL INFORMATION

| | |
|--|---|
| Installation Guidelines | 3 |
| General Description | 4 |
| Architect/Engineer Information | 5 |

For panel load tables and other technical data, please inquire or visit our website at www.metlspan.com.

| | |
|-----------------------------|---------|
| Product Checklist | 6 - 12 |
| Unloading | 13 - 16 |
| Storage | 17 - 18 |
| Panel Staging | 19 - 20 |
| Handling Panels | 21 |
| Manually | 22 |
| Mechanically | 23 - 25 |

WALL APPLICATIONS

| | |
|---|---------|
| Panel Orientation | 26 - 27 |
| Fastener Patterns and Substrate Attachment | 28 |
| Preparatory Requirements | 29 - 34 |
| Wall Layout | 35 - 36 |
| Panel Sealant Requirements | 37 |
| Panel Joint Engagement | 38 |
| Base | 39 |
| Intermediate Supports | 39 |
| Eave/Rake | 40 |
| Corners | 41 - 42 |
| Framed Openings | 43 - 49 |
| Door Openings | 50 - 53 |
| Panel Installation | |
| First Panel | 54 |
| Intermediate Panels | 55 |
| Quality Control | 56 |
| Details | |
| Fastener and Joint Sealant Application | 57 |
| Wall Base With Recess | 58 |
| Wall Base Without Recess | 59 |
| Outside Corner | 60 |
| Inside Corner | 61 |
| Framed Opening | 62 |
| . . . Head Detail At Window | 62 |
| . . . Sill Detail At Window | 63 |
| . . . Jamb Detail At Window | 64 |
| . . . Wall Stack Join With Cold Formed Member | 65 |
| . . . Wall Lap With Cold Formed Window | 66 |

TABLE OF CONTENTS

ROOF INSTALLATION SEQUENCE

| | |
|--|---------|
| Panel Orientation | 67 |
| RWP Floor Panel – Fastener Placement | 68 |
| Preparatory Requirements | 69 - 72 |
| Roof Layout | 73 |
| Step 1-Preparation for First Panel | 74 - 76 |
| Step 2-First Panel Installation. | 77 - 78 |
| Step 3-Subsequent Runs-Eave. | 79 - 81 |
| Step 4-End Lap | 82 - 83 |
| Step 5-Subsequent Runs-End Lap. | 84 - 85 |
| Step 6-Ridge | 86 |
| Step 7-Subsequent Runs-Ridge. | 87 |
| Step 8-Last Panel Run. | 88 - 89 |
| Step 9-Rake Zee Installation | 90 - 91 |
| Step 10-Outside Closure Installation. | 92 - 93 |

DETAILS

| | |
|---|-----|
| Fastener and Joint Sealant Application. | 94 |
| Ridge Detail With Expandable Trim | 95 |
| Panel End Lap at Cold Formed Zee | 96 |
| High Eave | 97 |
| Eave Trim With Eave | 98 |
| Eave With Gutter | 99 |
| Rake | 100 |
| Parapet High Eave. | 101 |
| Parapet Rake. | 102 |
| Hip | 103 |
| Valley. | 104 |

INSTALLATION GUIDELINES

I. Pre-Order

- A. Prior to ordering panels, all dimensions should be confirmed by field measurement.

II. Job Site Storage and Handling

- A. Check the shipment against the shipping list.
- B. Damaged material must be noted on bill of lading.
- C. Panels should be handled carefully. A spreader bar of appropriate length is recommended for hoisting.
- D. Check to see that moisture has not formed inside the bundles during shipment. If moisture is present, panels should be wiped dry, then restacked and loosely covered so that air can circulate between the panels.

III. Application Checklist

- A. Check substructure for proper alignment and uniformity to avoid panel distortion. See **pages 29 and 69** for further information.
- B. Periodic check of panel alignment is crucial to proper panel installation.
- C. For proper appearance, ribs should line up at hips, valleys and ridges.
- D. Panels should be cut on ground to minimize cut filings on roof. Keep panels clean during installation. Do not allow panels to come into contact with water runoff from lead, copper or graphite.

GENERAL DESCRIPTION
LS-36™ INSULATED METAL
ROOF & WALL PANEL

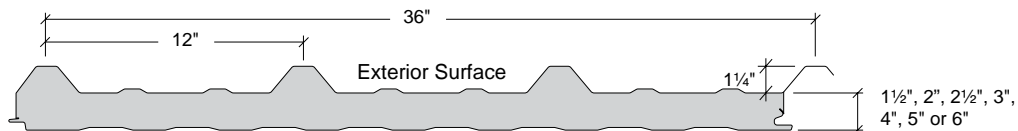

Coverage Width – 36"

Panel Attachment – Through Fastened

Panel Substrate – Galvalume® (standard); Galvanized (optional)

Exterior Panel Finishes – Smooth (standard); Embossed (optional)

Interior Panel Finishes – Stucco-embossed

Exterior Gauge – 26, 24, 22

Interior Gauge – 26, 24, 22

Exterior Coatings – Signature® 200, Signature® 300, Applied Finishes (for wall applications only)

Interior Coatings – Igloo White (standard)

Panel Thicknesses – 1½", 2", 2½", 3", 4", 5", 6"

Lengths – Recommended maximum is 50' Panel

Minimum Slope – ½":12

*See Metl-Span® Institutional, Commercial & Industrial color chart for available colors.
 Minimum quantities may be required.

NOTICE

Contact Metl-Span for Positive and Negative Wind Load information.

ARCHITECT/ENGINEER INFORMATION

Metl-Span® LS-36™ Insulated Metal Roof & Wall Panel is available in a 36" panel width and panel thicknesses of 1½", 2", 2½", 3", 4", 5" and 6". The LS-36™ offers you unparalleled energy efficiency that can be custom tailored to your project's specific needs. The LS-36™ can be used as either a wall panel or roof panel.

LS-36™ is recommended for roof slopes of ½:12 or greater.

LS-36™ is attached to the substructure with exposed through fasteners.

The roof must be erected left to right when viewed from the eave looking towards the ridge. Single run wall panels and stack joint wall panels with trim may be erected from either direction. Stack joining wall panels without trim requires installation to proceed left to right when viewed from ground facing building.

Metl-Span® provides full test data for the LS-36™ Insulated Metal Panel Roof System for each panel thickness including positive and negative loading, as well as R-values. See current load tables at www.metlspan.com.

LS-36™ is available in custom lengths up to 50'. For lengths over 50' please inquire.

Substructure must be on an even plane from ridge to eave or base angle to eave strut, extreme difficulty may be encountered in engaging panels (tolerance: ¼" in 20' or ⅜" in 40'). See pages 29 and 69 for further information.

LS-36™ is heavier and bulkier than single skin panels and therefore may require different equipment to unload and install, as well as different handling techniques. Review this manual carefully to ensure that you have a thorough understanding of these requirements before receiving material.

All material should be checked against the shipping list as it is being unloaded. Any shortages or damages must be noted on the Bill of Lading.

To provide consistent thermal values at cavities such as at corners, rake parapets or high eave parapets, filler insulation must be installed. Fiberglass insulation, not supplied by Metl-Span, is typically used and must be field cut to size and installed within the cavities. Failure to install insulation with these cavities will result in decreased thermal efficiency and may result in condensation and ice formation both within the cavity and the building's interior surfaces.

Because of the thermal efficiency of LS-36™ Insulated Metal Panels, the potential exists for a strong vapor drive between the interior and exterior of the walls and/or roof. This requires greater attention to the design and application of weather and vapor seals to prevent condensation in the wall or roof cavity or the interior surface of the wall or roof panels. Depending upon a given project's environmental conditions and the use of the building, the vapor drive may be to the interior or exterior. It is the designer's responsibility to understand the project's environmental and operating conditions and to specify the appropriate vapor control measures.

Panels are subject to oil canning due to improper handling, substructure misalignment, overdriving clip fasteners and thermal issues related to panel color and orientation to sun exposure. Since many uncontrollable factors are causes for oil canning, no manufacturer can realistically assure the total elimination of the phenomenon. With careful attention to material selection, panel design and installation, oil canning can be minimized. Oil canning is not a cause for rejection.

As with all insulated foam panels, careful attention should be given to the attachment of the panels to the building's structural framing. Because foam panels do not float but expand when heated, causing "thermal bow", long panel lengths, dark colors and attachment to members that may deflect under load, can cause excessive oil canning or stress buckling of the exterior panel skin. Please contact Metl-Span for further information when designing structures that may incorporate these design elements.

For projects in which the panel's interior skin will be washed down frequently, such as food processing plants, consideration should be given to whether the metal skin should be embossed. Special prefinished unembossed material is available for this purpose. However, the possibility of metal waviness and oil canning must be addressed. Plastisol coated material or bare stainless steel material are also options for this condition. Please contact Metl-Span for more information.





NOTE

When vapor seal is required at exterior side of panel, apply ½" x ⅜" tape sealer to panel side lap.

CAUTION

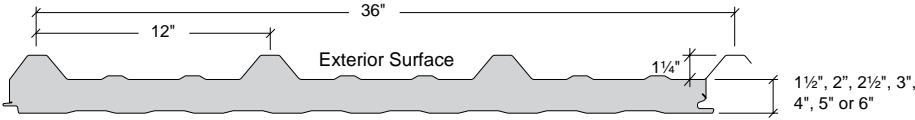
Diaphragm capabilities and purlin stability are not provided by **Metl-Span's LS-36™**. Therefore, other bracing may be required to conform to A.I.S.C. or A.I.S.I specifications.

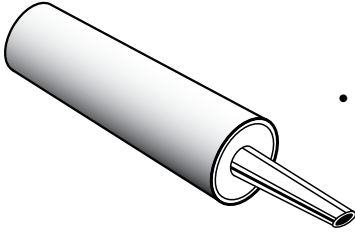
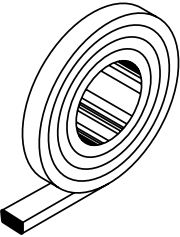
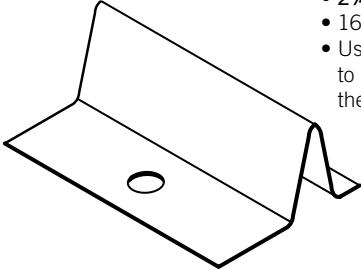
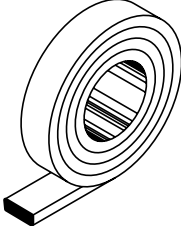
PRODUCT CHECKLIST

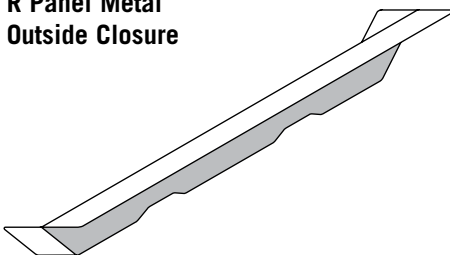
| | |
|--|--|
| <p>Insulated R Panel</p>  <p style="text-align: right;">Panel Thickness</p> <p>1 1/2" <input type="checkbox"/> 4" <input type="checkbox"/></p> <p>2" <input type="checkbox"/> 5" <input type="checkbox"/></p> <p>2 1/2" <input type="checkbox"/> 6" <input type="checkbox"/></p> <p>3" <input type="checkbox"/></p> | |
| <p>Triple Bead Tape Sealer</p> <ul style="list-style-type: none"> • 20'-0" length • 2 1/2" x 3/16" • For use at valleys  <p style="text-align: right;">HW-502 <input type="checkbox"/></p> | <p>Urethane Sealant</p>  <ul style="list-style-type: none"> • Urethane <ul style="list-style-type: none"> HW-540 - (White) <input type="checkbox"/> HW-541 - (Gray) <input type="checkbox"/> HW-542 - (Bronze) <input type="checkbox"/> HW-544 - (Almond) <input type="checkbox"/> • Non-Skinning Butyl <ul style="list-style-type: none"> • For use at vapor groove 7100 - (White) <input type="checkbox"/> |
| <p>Side Lap Tape Sealer</p> <ul style="list-style-type: none"> • 50'-0" length • 3/32" thickness • 1/2" width  <p style="text-align: right;">HW-507 <input type="checkbox"/></p> | <p>Cee Clip</p> <ul style="list-style-type: none"> • 2 3/4" length • 16 gauge Galvanized • Used at door openings to attach panel from the back side.  <p style="text-align: right;">4805 <input type="checkbox"/></p> |
| <p>Tape Sealer</p> <ul style="list-style-type: none"> • 40'-0" length • 1/8" thickness • 1" width • Use at trim conditions  <p style="text-align: right;">7300 <input type="checkbox"/></p> | <p>Fastener #14</p> <ul style="list-style-type: none"> • Trim to trim connection • Stainless Steel • 1/8" Diameter • 3/16" Grip Range  <p style="text-align: right;">Fastener #14 <input type="checkbox"/> 1/8" x 3/16" Pop Rivet</p> |
| <p>R Panel Metal Outside Closure</p> <ul style="list-style-type: none"> • 26 gauge material • 3 required per panel  <p style="text-align: right;">HW-4041 <input type="checkbox"/></p> | |

PRODUCT CHECKLIST

**Wall Fasteners
Face Fasten - Panel Flat**



- For fastening Wall Panels to 16-12 Ga. Steel
- For fastening Rake Zee to 16-12 Ga. Steel
- 3/8" Hex Washer Head w/ 5/8" O.D. Washer

Fastener #1124

1/4"-14 x 3" TEK 3
Panel Thickness: 1 1/2" and 2"

Fastener #1132

1/4"-14 x 4" TEK 3
Panel Thickness: 2 1/2" and 3"

Fastener #1140

1/4"-14 x 5" TEK 3
Panel Thickness: 4"

Fastener #1148

1/4"-14 x 6" TEK 3
Panel Thickness: 5"

Fastener #1156

1/4"-14 x 7" TEK 3
Panel Thickness: 6"

**Wall Fasteners
Face Fasten - Panel Flat**



- For fastening Wall Panel to 3/16"-1/2" Steel
- For fastening Rake Zee to 3/16"-1/2" Steel
- 3/8" Hex Washer Head w/ 5/8" O.D. Washer

Fastener #1232

1/4"-14 x 4" TEK 5
Panel Thickness: 1 1/2" and 2"

Fastener #1240

1/4"-14 x 5" TEK 5
Panel Thickness: 2 1/2" and 3"

Fastener #1248

1/4"-14 x 6" TEK 5
Panel Thickness: 4"

Fastener #1256

1/4"-14 x 7" TEK 5
Panel Thickness: 5"

Fastener #1264

1/4"-14 x 8" TEK 5
Panel Thickness: 6"

**Wall Fasteners - Alternate
Face Fasten-Panel Flat**



- Alternate Fastener used to face fasten wall panels or Rake Zee into steel. Any thickness, minimum 16 Ga.
- 3/8" Hex Washer Head w/ 5/8" O.D. Washer
- Requires a 0.201" Pilot Hole

Fastener #1324

1/4"-14 x 3" Type B
Panel Thickness: 1 1/2" and 2"

Fastener #1332

1/4"-14 x 4" Type B
Panel Thickness: 2 1/2" and 3"

Fastener #1340

1/4"-14 x 5" Type B
Panel Thickness: 4"

Fastener #1348

1/4"-14 x 6" Type B 3
Panel Thickness: 5"

Fastener #1364

1/4"-14 x 8" Type B
Panel Thickness: 6"

**Roof Fasteners -
Face Fasten-Panel Rib**

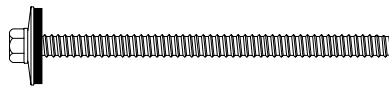

- 3/8" Hex Washer Head w/ 1" O.D. Washer
- Requires a 0.201" Pilot Hole

Fastener #2332S

1/4"-14 x 4" Type B 304 Stainless
Panel Thickness: 1 1/2" and 2"

Fastener #2340S

1/4"-14 x 5" Type B 304 Stainless
Panel Thickness: 2 1/2" and 3"

Fastener #2348S

1/4"-14 x 6" Type B 304 Stainless
Panel Thickness: 4"

Fastener #2364S

1/4"-14 x 8" Type B 304 Stainless
Panel Thickness: 5" and 6"

Bulb-Tite Fasteners

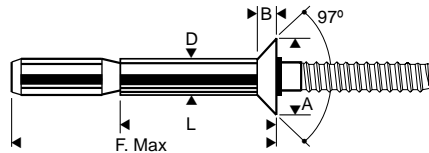

- 3/32" BT Dome Head w/Washer

Fastener #2605ANC

Bulb-Tite Compression Fastener
Grip Range: 1/4"-3/8"

Fastener #2606ANC

Bulb-Tite Compression Fastener - 10-12
Grip Range: 3/8"-1/2"

Bulb-Tite Rivet Tool is require to install this fastener

Fastener #4A

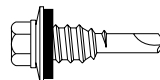

- Use to attach trim to panels
- Use at end laps and attaching outside closure to panel
- 3/16" Hex Washer Head w/ 5/8" O.D. Washer

Fastener #4A

1/4"-14 x 3/8" LapTEK

Fastener #12A

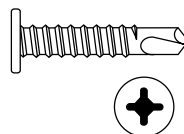

- Use at Rake Angle attachment

Fastener #12A

12 x 1" Pancake Head Driller
#2 Quadrex Drive Pankcake Head

PRODUCT CHECKLIST

Inside Corner Trim-Flat

- Interior surface only
- Trim is embossed as standard
- Order trim length as required - Maximum trim length is 20' - Allow 2" for lapping trim

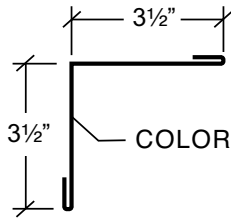

F-5140

Panel Thickness: 1½", 2", 2½", 3", 4", 5" and 6"

Inside Corner Trim-Offset

- Exterior surface only
- Trim is smooth as standard
- Order trim length as required - Maximum trim length is 20' - Allow 2" for lapping trim

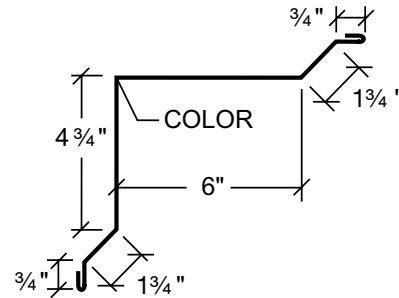

F-3219

Panel Thickness: 1½", 2", 2½", 3", 4", 5" and 6"

Outside Corner Trim-Offset

- Exterior surface only
- Trim is smooth as standard
- Order trim length as required - Maximum trim length is 20' - Allow 2" for lapping trim

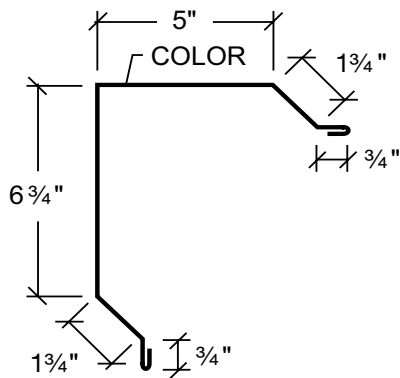

F-3229

Dim. "A" = 5"
Dim. "B" = 6¾"

Panel Thickness: 1½", 2", 2½" and 3"

F-3231

Dim. "A" = 8¼"
Dim. "B" = 10"

Panel Thickness: 4", 5" and 6"

Base Trim

- Trim is smooth as standard
- Order trim length as required - Maximum trim length is 20' - Allow 2" for lapping trim

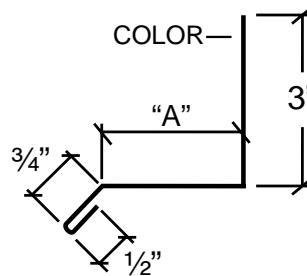

F-5036

Dim. "A" = 4½"
Panel Thickness: 3"

F-5060

Dim. "A" = 3"
Panel Thickness: 1½"

F-5005

Dim. "A" = 3½"
Panel Thickness: 2"

F-5017

Dim. "A" = 4"
Panel Thickness: 2½"

F-5055

Dim. "A" = 5½"
Panel Thickness: 4"

F-4026

Dim. "A" = 6½"
Panel Thickness: 5"

F-4027

Dim. "A" = 7½"
Panel Thickness: 6"

PRODUCT CHECKLIST

Head Trim

- Trim is smooth as standard
- Order trim length as required - Maximum trim length is 20' - Allow 2" for lapping trim

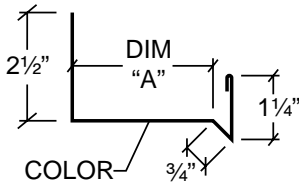

- | | |
|--|--|
| F-3241 <input type="checkbox"/> | F-3244 <input type="checkbox"/> |
| Dim. "A" = 3" | Dim. "A" = 4" |
| Panel Thickness: 1 1/2" | Panel Thickness: 2 1/2" |
| F-3242 <input type="checkbox"/> | F-3245 <input type="checkbox"/> |
| Dim. "A" = 3 1/2" | Dim. "A" = 5 1/2" |
| Panel Thickness: 2" | Panel Thickness: 4" |
| F-3243 <input type="checkbox"/> | F-3246 <input type="checkbox"/> |
| Dim. "A" = 4 1/2" | Dim. "A" = 6 1/2" |
| Panel Thickness: 3" | Panel Thickness: 5" |
| | F-3247 <input type="checkbox"/> |
| | Dim. "A" = 7 1/2" |
| | Panel Thickness: 6" |

Sill Trim

- Trim is smooth as standard
- Order trim length as required - Maximum trim length is 20' - Allow 2" for lapping trim

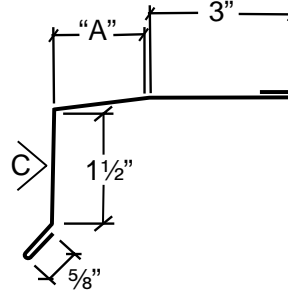

- | | |
|--|--|
| F-4052 <input type="checkbox"/> | F-4058 <input type="checkbox"/> |
| Dim. "A" = 2 13/16" | Dim. "A" = 4 5/16" |
| Panel Thickness: 1 1/2" | Panel Thickness: 3" |
| F-4054 <input type="checkbox"/> | F-4060 <input type="checkbox"/> |
| Dim. "A" = 3 5/16" | Dim. "A" = 5 5/16" |
| Panel Thickness: 2" | Panel Thickness: 4" |
| F-4056 <input type="checkbox"/> | F-4062 <input type="checkbox"/> |
| Dim. "A" = 3 13/16" | Dim. "A" = 6 1/16" |
| Panel Thickness: 2 1/2" | Panel Thickness: 5" |
| | F-4064 <input type="checkbox"/> |
| | Dim. "A" = 7 1/16" |
| | Panel Thickness: 6" |

Jamb Trim

- Trim is smooth as standard
- Order trim length as required - Maximum trim length is 20' - Allow 2" for lapping trim

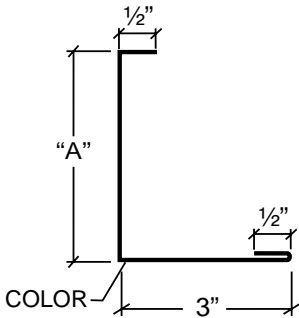

- | | |
|--|--|
| F-4036 <input type="checkbox"/> | F-4042 <input type="checkbox"/> |
| Dim. "A" = 2 7/8" | Dim. "A" = 4 3/8" |
| Panel Thickness: 1 1/2" | Panel Thickness: 3" |
| F-4038 <input type="checkbox"/> | F-4044 <input type="checkbox"/> |
| Dim. "A" = 3 3/8" | Dim. "A" = 5 3/8" |
| Panel Thickness: 2" | Panel Thickness: 4" |
| F-4040 <input type="checkbox"/> | F-4046 <input type="checkbox"/> |
| Dim. "A" = 3 7/8" | Dim. "A" = 6 3/8" |
| Panel Thickness: 2 1/2" | Panel Thickness: 5" |
| | F-4047 <input type="checkbox"/> |
| | Dim. "A" = 7 3/8" |
| | Panel Thickness: 6" |

Jamb Filler Trim

- Trim is smooth as standard
- Order trim length as required - Maximum trim length is 14' - Allow 2" for lapping trim

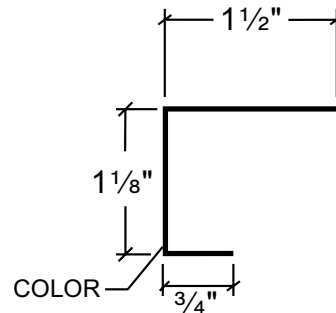

- | |
|--|
| F-4048 <input type="checkbox"/> |
| Panel Thickness: 1 1/2", 2", 2 1/2", 3", 4", 5" and 6" |

PRODUCT CHECKLIST

Stack Joint Trim

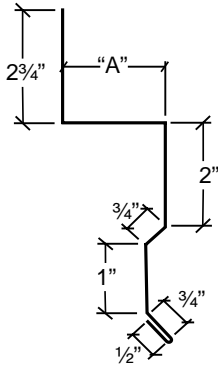

- Trim is smooth as standard
- Order trim length as required - Maximum trim length is 20' - Allow 2" for lapping trim

- F-4068**
Dim. "A" = 3 3/8"
Panel Thickness: 17/8"
- F-4070**
Dim. "A" = 3 7/8"
Panel Thickness: 2"
- F-4072**
Dim. "A" = 4 3/8"
Panel Thickness: 2 1/2"

- F-4074**
Dim. "A" = 4 7/8"
Panel Thickness: 3"
- F-4076**
Dim. "A" = 5 7/8"
Panel Thickness: 4"
- F-4094**
Dim. "A" = 6 7/8"
Panel Thickness: 5"
- F-4096**
Dim. "A" = 7 7/8"
Panel Thickness: 6"

Drip Trim

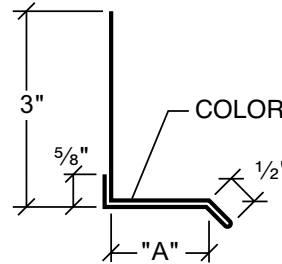

- Trim is smooth as standard
- Order trim length as required - Maximum trim length is 20' - Allow 2" for lapping trim

- F-3290**
Dim. "A" = 3"
Panel Thickness: 1 1/2"
- F-3291**
Dim. "A" = 3 1/2"
Panel Thickness: 2"
- F-3292**
Dim. "A" = 4"
Panel Thickness: 2 1/2"

- F-3293**
Dim. "A" = 4 1/2"
Panel Thickness: 3"
- F-3294**
Dim. "A" = 5 1/2"
Panel Thickness: 4"
- F-3295**
Dim. "A" = 6 1/2"
Panel Thickness: 5"
- F-3296**
Dim. "A" = 7 1/2"
Panel Thickness: 6"

Sculptured Rake

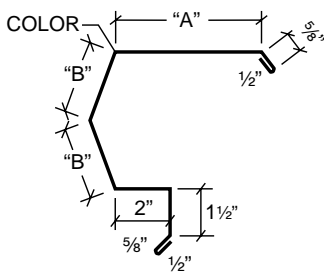

- Trim is smooth as standard
- Order trim length as required - Maximum trim length is 20' - Allow 2" for lapping trim

| Part No. | Dim. "A"/"B" | Roof Thickness | Wall Thickness | <input type="checkbox"/> |
|---------------|--------------|----------------|----------------|--------------------------|
| F-3481 | 11 1/4" | 1 1/2" - 4" | 1 1/2" - 3" | <input type="checkbox"/> |
| F-3482 | 11 5/8" | 5" - 6" | 1 1/2" - 3" | <input type="checkbox"/> |
| F-3483 | 13 1/4" | 1 1/2" - 4" | 4" - 6" | <input type="checkbox"/> |
| F-3484 | 13 5/8" | 5" - 6" | 4" - 6" | <input type="checkbox"/> |

Sculptured High Side Eave

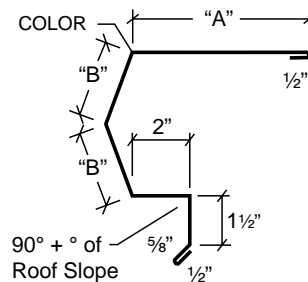

- Specify roof slope
- Trim is smooth as standard
- Use with F-3481, F-3482, F-3483 and F-3484 Sculptured Rake
- Order trim length as required - Maximum trim length is 20' - Allow 2" for lapping trim

| Part No. | Dim. "A"/"B" | Roof Thickness | Wall Thickness | <input type="checkbox"/> |
|---------------|----------------|----------------|----------------|--------------------------|
| F-3471 | 11 1/4" | 1 1/2" - 4" | 1 1/2" - 3" | <input type="checkbox"/> |
| F-3457 | 13 1/2"/4" | 1 1/2" - 4" | 4" - 6" | <input type="checkbox"/> |
| F-3458 | 11 5/8" | 5" - 6" | 1 1/2" - 3" | <input type="checkbox"/> |
| F-3472 | 13 1/2"/5 1/4" | 5" - 6" | 4" - 6" | <input type="checkbox"/> |

Rake Trim End Cap

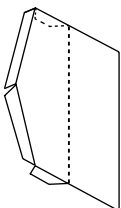

- End cap will be made to fit rake ordered
- Specify left or right
- Specify rake part number

F-3451

PRODUCT CHECKLIST

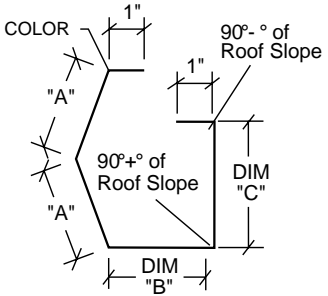
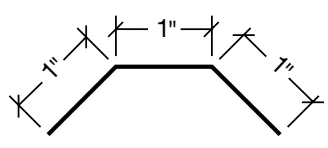
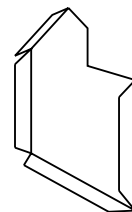
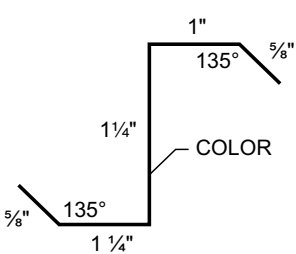
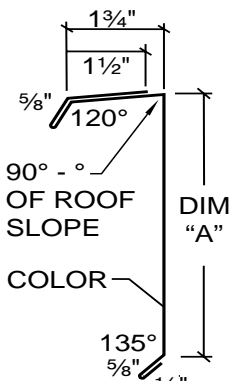
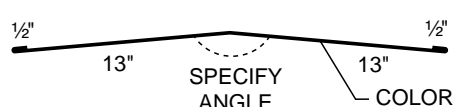
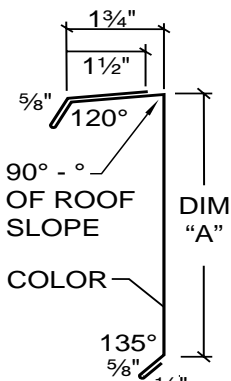
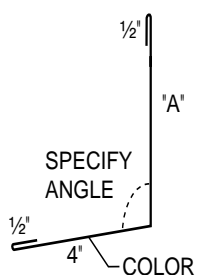
| <p>Sculptured Hang-on Gutter</p>  <ul style="list-style-type: none"> Specify roof slope Trim is smooth as standard Use with F-3485 and F-3486 eave trim Order trim length as required - Maximum trim length is 20' - Allow 2" for lapping trim <table border="1"> <thead> <tr> <th>Part No.</th> <th>Dim. "A"/"B"/"C"</th> <th>Roof Thickness</th> <th>Roof Slope</th> <th></th> </tr> </thead> <tbody> <tr> <td rowspan="2">F-3462</td> <td>4"/6½"/6⅝"</td> <td>1½" - 4"</td> <td>½ - 2:12</td> <td><input type="checkbox"/></td> </tr> <tr> <td>4"/6¼"/6⅞"</td> <td>1½" - 4"</td> <td>3 - 4:12</td> <td><input type="checkbox"/></td> </tr> <tr> <td rowspan="2">F-3464</td> <td>5¼"/6⅝"/9¼"</td> <td>5" - 6"</td> <td>½ - 2:12</td> <td><input type="checkbox"/></td> </tr> <tr> <td>5¼"/6¼"/9⅞"</td> <td>5" - 6"</td> <td>3 - 4:12</td> <td><input type="checkbox"/></td> </tr> </tbody> </table> | Part No. | Dim. "A"/"B"/"C" | Roof Thickness | Roof Slope | | F-3462 | 4"/6½"/6⅝" | 1½" - 4" | ½ - 2:12 | <input type="checkbox"/> | 4"/6¼"/6⅞" | 1½" - 4" | 3 - 4:12 | <input type="checkbox"/> | F-3464 | 5¼"/6⅝"/9¼" | 5" - 6" | ½ - 2:12 | <input type="checkbox"/> | 5¼"/6¼"/9⅞" | 5" - 6" | 3 - 4:12 | <input type="checkbox"/> | <p>Gutter Strap</p> <ul style="list-style-type: none"> 12" Long  <p>F-893 <input type="checkbox"/></p> |
|---|--|--------------------------|--------------------------|--------------------------|----------------|--------------------------|---------------|----------------|--------------------------|---|------------|----------|--------------------------|--------------------------|---------------|-------------|---------|----------|--------------------------|-------------|---------|----------|--------------------------|---|
| Part No. | Dim. "A"/"B"/"C" | Roof Thickness | Roof Slope | | | | | | | | | | | | | | | | | | | | | |
| F-3462 | 4"/6½"/6⅝" | 1½" - 4" | ½ - 2:12 | <input type="checkbox"/> | | | | | | | | | | | | | | | | | | | | |
| | 4"/6¼"/6⅞" | 1½" - 4" | 3 - 4:12 | <input type="checkbox"/> | | | | | | | | | | | | | | | | | | | | |
| F-3464 | 5¼"/6⅝"/9¼" | 5" - 6" | ½ - 2:12 | <input type="checkbox"/> | | | | | | | | | | | | | | | | | | | | |
| | 5¼"/6¼"/9⅞" | 5" - 6" | 3 - 4:12 | <input type="checkbox"/> | | | | | | | | | | | | | | | | | | | | |
| <p>Gutter Ends (Left or Right)</p>  <ul style="list-style-type: none"> Use with sculptured gutters Endcaps will be made to fit gutter ordered Specify left or right Specify gutter part number <table border="1"> <thead> <tr> <th>Gutter No.</th> <th>Gutter End</th> <th></th> </tr> </thead> <tbody> <tr> <td>F-3462</td> <td>FL-3160</td> <td><input type="checkbox"/></td> </tr> <tr> <td>F-3464</td> <td>FL-3161</td> <td><input type="checkbox"/></td> </tr> </tbody> </table> | Gutter No. | Gutter End | | F-3462 | FL-3160 | <input type="checkbox"/> | F-3464 | FL-3161 | <input type="checkbox"/> | <p>Insulated R Panel Rake Zee</p> <ul style="list-style-type: none"> Trim is smooth as standard Order trim length as required - Maximum trim length is 10' - Allow 2" for lapping trim  <p>F-3469 <input type="checkbox"/></p> | | | | | | | | | | | | | | |
| Gutter No. | Gutter End | | | | | | | | | | | | | | | | | | | | | | | |
| F-3462 | FL-3160 | <input type="checkbox"/> | | | | | | | | | | | | | | | | | | | | | | |
| F-3464 | FL-3161 | <input type="checkbox"/> | | | | | | | | | | | | | | | | | | | | | | |
| <p>Low Eave Trim</p>  <ul style="list-style-type: none"> Trim is smooth as standard Order trim length as required - Maximum trim length is 20' - Allow 2" for lapping trim <p>F-3454 <input type="checkbox"/> Dim. "A" = 7⅞"</p> <p>Panel Thickness: 1½", 2", 2½", 3" and 4"</p> <p>F-3453 <input type="checkbox"/> Dim. "A" = 10⅝"</p> <p>Panel Thickness: 5" and 6"</p> | <p>Interior Ridge Trim</p> <ul style="list-style-type: none"> Trim is embossed as standard 26-gauge material Specify roof slope or angle Order trim length as required - Maximum trim length is 10' - Allow 2" for lapping trim  <p>F-3450 <input type="checkbox"/></p> | | | | | | | | | | | | | | | | | | | | | | | |
| <p>Low Eave Trim</p>  <ul style="list-style-type: none"> Trim is smooth as standard Order trim length as required - Maximum trim length is 20' - Allow 2" for lapping trim <p>F-3454 <input type="checkbox"/> Dim. "A" = 7⅞"</p> <p>Panel Thickness: 1½", 2", 2½", 3" and 4"</p> <p>F-3453 <input type="checkbox"/> Dim. "A" = 10⅝"</p> <p>Panel Thickness: 5" and 6"</p> | <p>Interior Transition Trim</p> <ul style="list-style-type: none"> Trim is embossed as standard 26-gauge material Specify roof slope or angle Order trim length as required - Maximum trim length is 20' - Allow 2" for lapping trim  <table border="1"> <thead> <tr> <th>Part No.</th> <th>Dim. "A"</th> <th>Panel Thickness</th> <th></th> </tr> </thead> <tbody> <tr> <td>F-3412</td> <td>9"</td> <td>1½" - 3"</td> <td><input type="checkbox"/></td> </tr> <tr> <td>F-3413</td> <td>12"</td> <td>4" - 6"</td> <td><input type="checkbox"/></td> </tr> </tbody> </table> | Part No. | Dim. "A" | Panel Thickness | | F-3412 | 9" | 1½" - 3" | <input type="checkbox"/> | F-3413 | 12" | 4" - 6" | <input type="checkbox"/> | | | | | | | | | | | |
| Part No. | Dim. "A" | Panel Thickness | | | | | | | | | | | | | | | | | | | | | | |
| F-3412 | 9" | 1½" - 3" | <input type="checkbox"/> | | | | | | | | | | | | | | | | | | | | | |
| F-3413 | 12" | 4" - 6" | <input type="checkbox"/> | | | | | | | | | | | | | | | | | | | | | |

PRODUCT CHECKLIST

Parapet Rake Trim

- Trim is smooth as standard
- Order trim length as required - Maximum trim length is 20'- Allow 2" for lapping trim

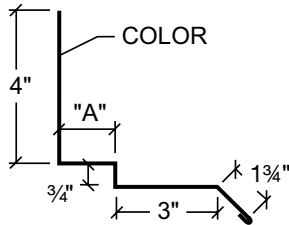

- | | |
|--|--|
| F-3760 <input type="checkbox"/> | F-3764 <input type="checkbox"/> |
| Dim. "A" = 3" | Dim. "A" = 5 1/2" |
| Panel Thickness: 1 1/2" | Panel Thickness: 4" |
| F-3761 <input type="checkbox"/> | F-3765 <input type="checkbox"/> |
| Dim. "A" = 3 1/2" | Dim. "A" = 6 1/2" |
| Panel Thickness: 2" | Panel Thickness: 5" |
| F-3762 <input type="checkbox"/> | F-3766 <input type="checkbox"/> |
| Dim. "A" = 4" | Dim. "A" = 7 1/2" |
| Panel Thickness: 2 1/2" | Panel Thickness: 6" |

Parapet High Eave Trim

- Trim is smooth as standard
- Order trim length as required - Maximum trim length is 20'- Allow 2" for lapping trim

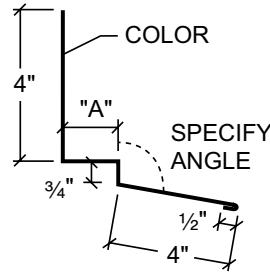

- | | |
|--|--|
| F-3490 <input type="checkbox"/> | F-3493 <input type="checkbox"/> |
| Dim. "A" = 3" | Dim. "A" = 4 1/2" |
| Panel Thickness: 1 1/2" | Panel Thickness: 3" |
| F-3491 <input type="checkbox"/> | F-3494 <input type="checkbox"/> |
| Dim. "A" = 3 1/2" | Dim. "A" = 5 1/2" |
| Panel Thickness: 2" | Panel Thickness: 4" |
| F-3492 <input type="checkbox"/> | F-3495 <input type="checkbox"/> |
| Dim. "A" = 4" | Dim. "A" = 6 1/2" |
| Panel Thickness: 2 1/2" | Panel Thickness: 5" |
| | F-3496 <input type="checkbox"/> |
| | Dim. "A" = 7 1/2" |
| | Panel Thickness: 6" |

Valley Support Plate

- 14-gauge Red Oxide
- Specify roof slope or angle
- 10'-0" long

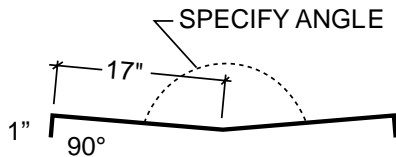

P-101

Valley Trim

- Trim is smooth as standard
- 26-gauge material
- Specify roof slope or angle
- Order trim length as required - Maximum trim length is 10'- Allow 2" for lapping trim

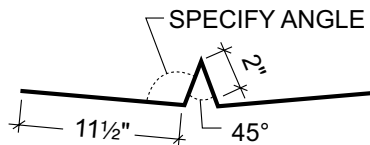

F-3502

Hip Support Plate

- 14-gauge Red Oxide
- Specify roof slope or angle
- 10'-0" long

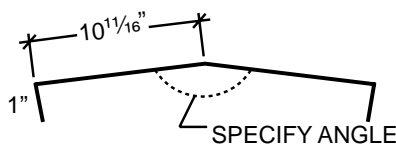

P-141

Exterior Ridge/Hip Trim

- Trim is smooth as standard
- 26-gauge material
- Specify roof slope or angle indicated on drawing
- Order trim length as required - Maximum trim length is 20'- Allow 2" for lapping trim

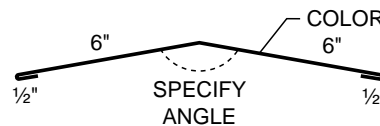

F-3445

GENERAL INFORMATION

LS-36™ INSULATED METAL ROOF & WALL PANEL

JOB #: 3422733
 EXT COIL #: 51743141101
 EXT COIL SIZE: 22 GA X 41.563 "
 EXT COIL COLOR: CLEAR
 INT COIL #: 51742941301
 INT COIL SIZE: 26 GA X 39.625 "
 INT COIL COLOR: USDA
 BUNDLE NO: 5 OF --

SHIP TO: SEPTAGON CONSTRUCTION CO INC
 2000 W GATWAY DR
 GRMELL, MS 39212
 P.O. BOX 115 720-1007
 CUST P.O. #: 000000000
 LHM: JACKSON
 PREPARED: 7-19-10

| DESCRIPTION | QTY | SHEET LENGTH |
|-------------|-----|---------------|
| GRV36--2.0" | 6 | 27' 1 - 0" |
| -- | 8 | 24' 6 - 1/2" |
| -- | 6 | 15' 7 - 0" |
| -- | 7 | 7' 5 - 1/2" |
| -- | 3 | 3' 1 - 0" |
| -- | -- | -- ' -- - --" |
| -- | -- | -- ' -- - --" |
| -- | -- | -- ' -- - --" |

UNLOADING

Before materials arrive at the job site, the contractor should determine how the trucks are to be unloaded and where the material will be staged. The contractor must determine the proper equipment and number of personnel required to safely unload and move the material.

Upon receiving material, check shipment against packing list for shortages and/or damages. Metl-Span® will not be responsible for shortages or damages unless they are noted on the shipping list.

The maximum weight of any one bundle will not exceed 7,500 lbs. Do not attempt to lift stacked bundles. Lift only one bundle at a time. Each bundle should be lifted at its center point or at lift points evenly spaced along length of bundle. Bundles feature bearing pads with sufficient elevation to allow a forklift or insertion of nylon slings when using a crane for easy unloading from the truck.

PACKING LIST

201 APACHE DRIVE
 PO BOX 720100
 JACKSON, MS 39272

SOLD TO: 142700
 SEPTAGON CONSTRUCTION CO INC

JOB NAME:

B
I
L
L
T
O
SEPTAGON CONSTRUCTION CO INC
2000 W GATWAY DR
GRMELL, MS 39212-0000
678 988 1012

S
H
I
P
T
O
SEPTAGON CONSTRUCTION CO INC
2000 W GATWAY DR
GRMELL, MS 39212

| DATE OF ORDER | LOAD DATE | CUSTOMER P.O. | SHIP VIA | SALESPERSON | BOL NUMBER | ORDER NUMBER |
|---------------|-----------|---------------|---------------|--------------|------------|--------------|
| 11-JUN-10 | 29-JUL-10 | 100061300001 | R & R EXPRESS | R. Lloyd IPS | 13555081 | 3422733 |

| ITEM | DESCRIPTION | PKG | AREA | Ga | COLOR | Sheet Length | Original Order Quantity | Shipped Quantity | Remaining Quantity |
|------|--|-----|------|----|---------|--------------|-------------------------|------------------|--------------------|
| 1000 | EMB GRV36 2.0" EMES 26 S230 BMAS *10* | | *10* | 22 | T-SNWHT | 24'- 6-1/2" | 4 | 4 | 0 |
| 2000 | EMB GRV36 2.0" EMES 26 S230 BMAS *10* | | *10* | 22 | T-SNWHT | 15'- 7" | 6 | 6 | 0 |
| 3000 | EMB GRV36 2.0" EMES 26 S230 BMAS *10* | | *10* | 22 | T-SNWHT | 7'- 5-1/2" | 2 | 2 | 0 |
| 4000 | EMB GRV36 2.0" EMES 26 S230 BMAS *10* | | *10* | 22 | T-SNWHT | 3'-11" | 8 | 8 | 0 |
| 5000 | EMB GRV36 2.0" EMES 26 S230 BMAS *10* | | *10* | 22 | T-SNWHT | 3'- 1" | 2 | 2 | 0 |
| 6000 | PANEL LAYOUT AT COL. LN *10* EMB GRV36 2.0" EMES 26 S230 BMAS *2A* | | *2A* | 22 | T-SNWHT | 24'- 6-1/2" | 2 | 2 | 0 |
| 7000 | EMB GRV36 2.0" EMES 26 S230 BMAS *2A* | | *2A* | 22 | T-SNWHT | 3'-11-1/2" | 1 | 1 | 0 |
| 8000 | PANEL LAYOUT AT COL. LN *2A* EMB GRV36 2.0" EMES 26 S230 | | *3* | 22 | T-SNWHT | 24'- 6-1/2" | 2 | 2 | 0 |

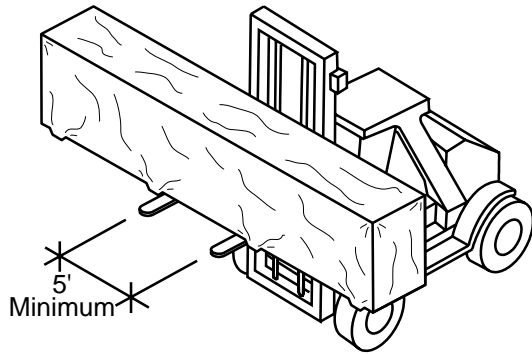

Unloading with One Fork Lift

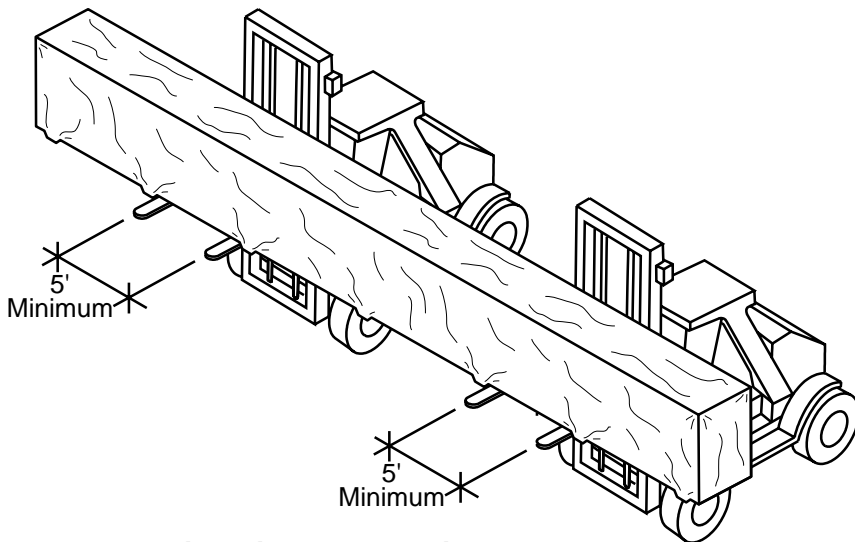

Unloading with Two Fork Lifts

UNLOADING (continued)

Unloading With A Forklift

Ensure that forks are spread apart as far as possible. Forks should be a minimum of 5' apart. Care should be taken to prevent fork damage to bundles on the opposite side of the truck. Avoid getting too far under the bundles and causing damage to the panel side laps with the mast of the forklift. Use care when moving panels. Drive slowly when traveling on rough terrain to prevent panel damage due to the bundles bouncing on the forks.

Shorter bundles can be moved with a single forklift. When two forklifts are required, this operation must be coordinated between the two forklift operators to ensure that each end of the bundle is raised and moved together. Guidelines for bundles requiring two forklifts:

1½", 2" & 2½" thick panels – 32' and longer

3", 4", 5" or 6" thick panels – 40' and longer

CAUTION

Improper unloading and handling of panel bundles may cause bodily injury or material damage. Metl-Span® is not responsible for bodily injuries or material damages during unloading and staging.

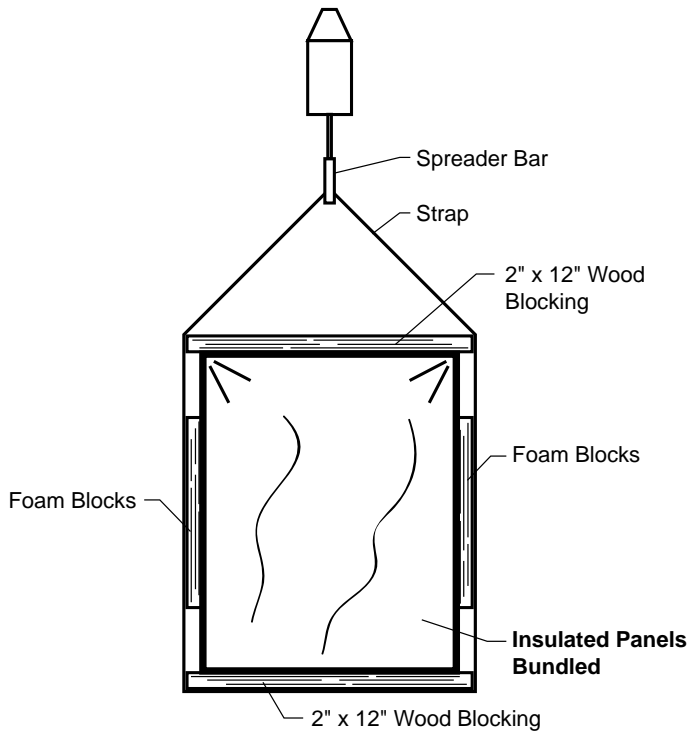

Unloading With A Crane

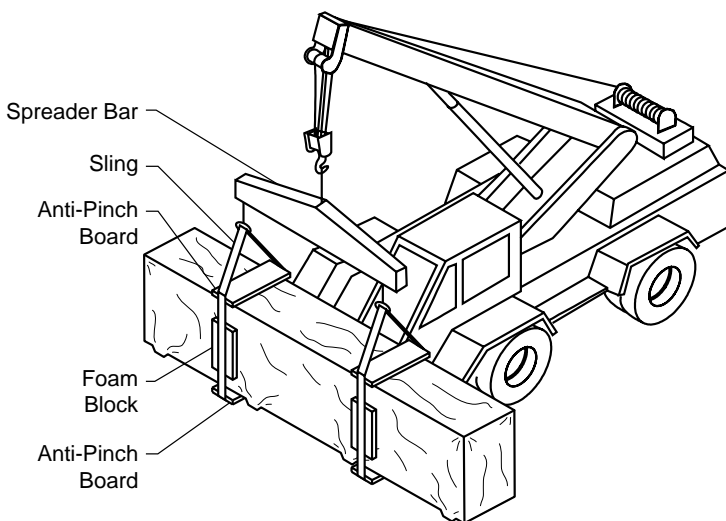

Bundles Under 4,000 lbs. and Under 44' in Length

UNLOADING (continued)

Unloading With A Crane

When lifting bundles with a crane, a spreader bar and slings should be used. Lifting slings must be minimum 6"-wide nylon straps. **NEVER USE WIRE OR ROPE OR CHAIN SLINGS. THEY WILL DAMAGE THE PANELS.** At each sling location, use boards at the top and bottom of the bundle to prevent the slings from crushing the edges of the panels. The boards should be 2"x12". Board length should equal the bundle width plus 4". At each side of the bundle, insert 2" thick foam blocks between the sling and the panel bundle. **LIFT ONLY ONE BUNDLE AT A TIME.**

The following is suggested rigging for various bundle lengths and weights. The final determination as to the best and safest rigging to use, based on equipment and job site conditions, is up to the contractor and crane operator.

Bundles under 4000 lbs. and under 44' in length

A single spreader bar with two slings may be used. Position slings at quarter points from each end of the bundle.

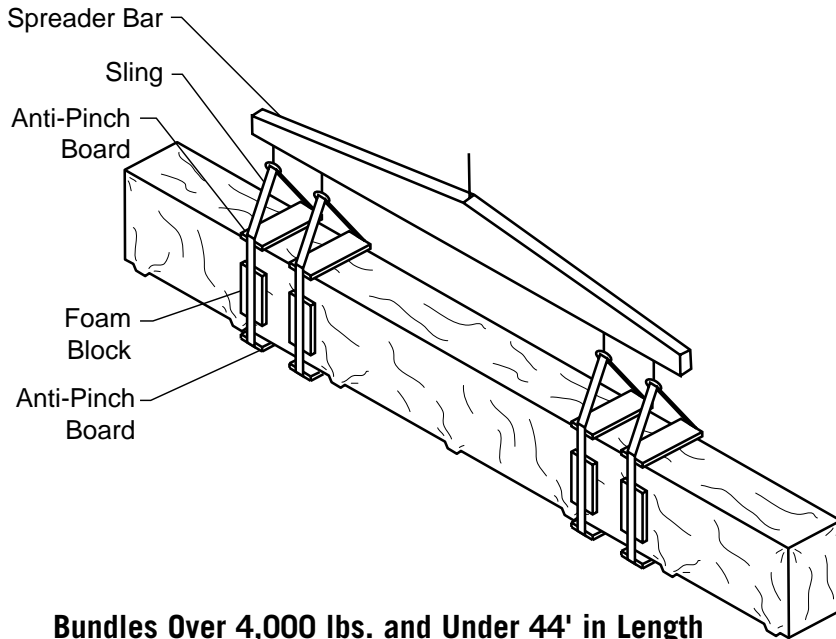

Bundles Over 4,000 lbs. and Under 44' in Length

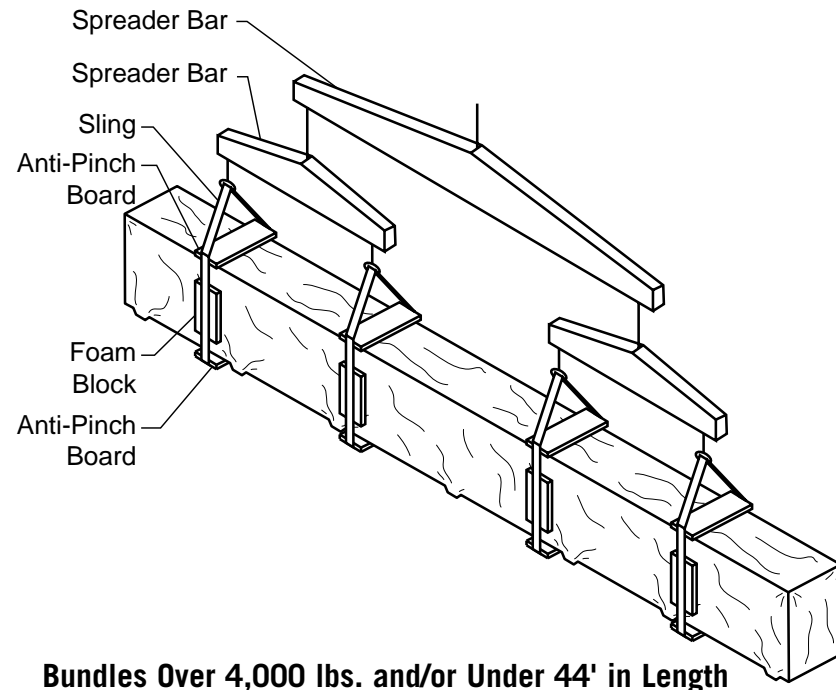

Bundles Over 4,000 lbs. and/or Under 44' in Length

UNLOADING (continued)

Bundles over 4000 lbs. and under 44' in length

A single spreader bar with four slings should be used. Position two sets of slings at each end of the spreader bar at quarter points from each end of the bundle.

Bundles over 4000 lbs. and/or over 44' in length

Ganged spreader bars with four slings should be used. The slings should be placed at even spaces along the length of the bundle.

CAUTION

Too few or too many lift points can cause damage to the panels. Improper unloading and handling of panel bundles may cause bodily injury or material damage. Metl-Span® is not responsible for bodily injuries or material damages during unloading and staging.

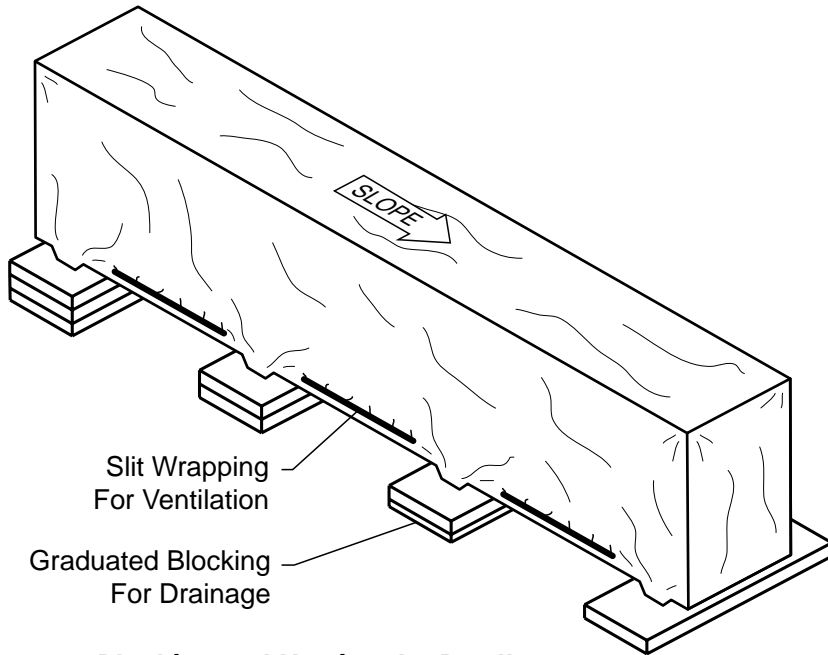

Blocking and Venting the Bundles

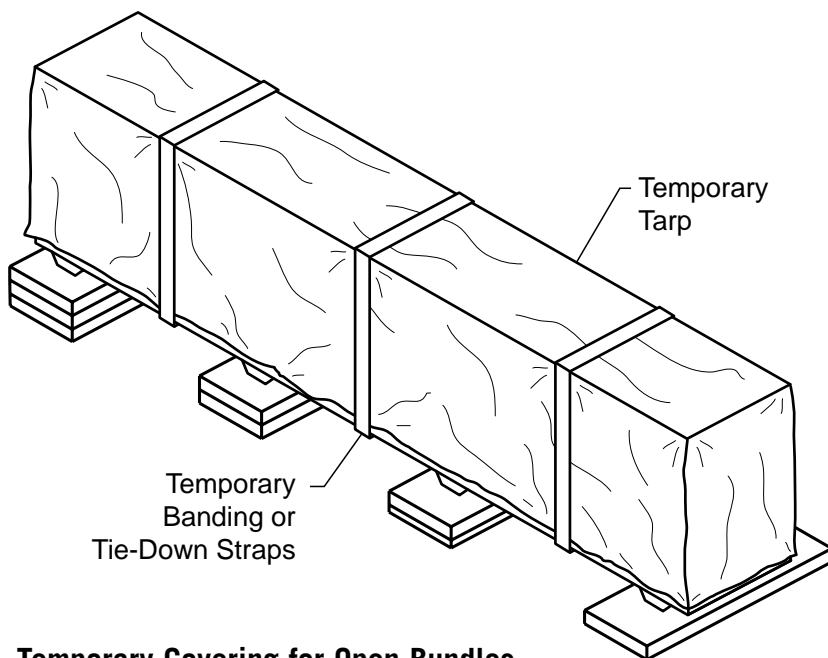

Temporary Covering for Open Bundles

STORAGE

The panels are shipped in stretch-wrapped bundles consisting of a single stack of panels in the flat position. The bundles must be protected against impact damage, water exposure and chemical contamination.

Store bundles off the ground sufficiently high enough to allow for air circulation beneath the bundle and to prevent water, mud or snow from entering. Slightly elevate one end of the bundle. Slit the stretch wrap at intervals along each side at the bottom of the bundles to allow for ventilation and evaporation of any moisture within the bundles.

Bundles that are opened but still have panels that have not been installed should be protected with a tarp or other waterproof cover to prevent exposure to water or contamination from construction residue. Opened bundles should be secured with banding or some other method to prevent damage by sudden high winds. Be sure not to over tighten and damage the panels. **MOVING BUNDLES AFTER THEY ARE OPENED MAY RESULT IN PANEL DAMAGE.**

CAUTION

Improper and/or prolonged storage of panels may cause damage to the panel finish. Metl-Span® is not responsible for panel damage caused by improper or prolonged storage of panels.

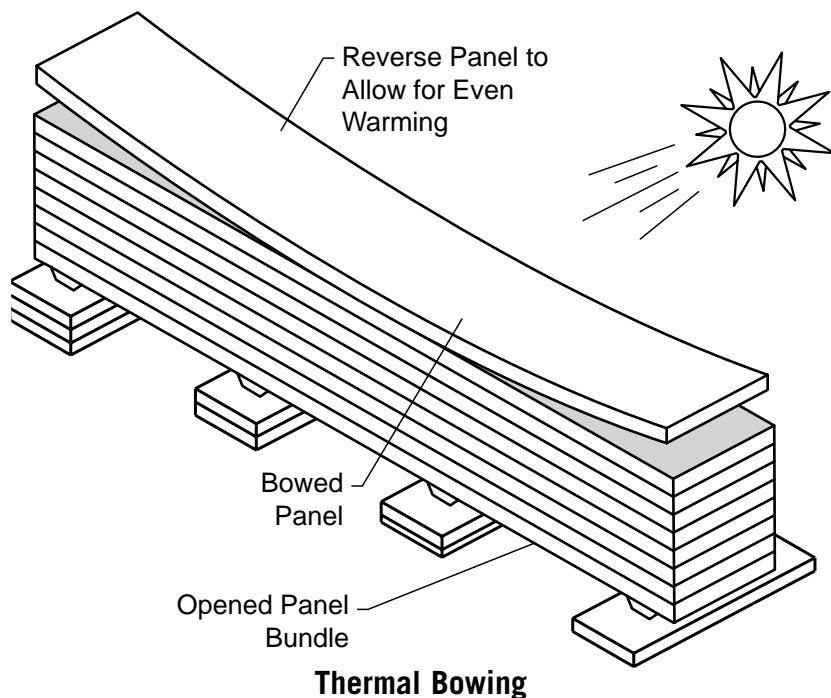
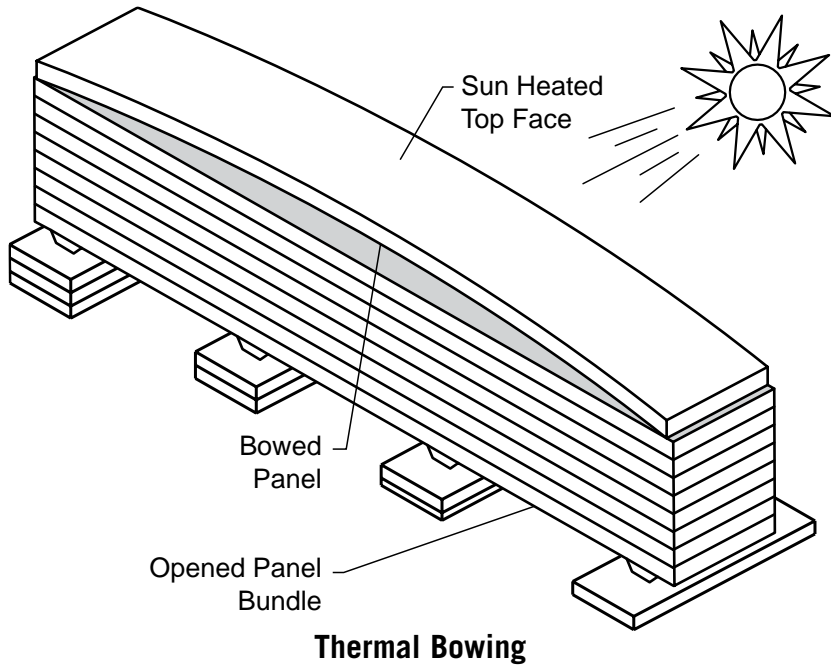

**STORAGE
(continued)**

Thermal Bow

When the top panel in a bundle is exposed to the hot sun, it may bow up, causing difficulty in engaging it to the previous panel during installation.

If this occurs, turn the panel over to allow the backside to warm equally, which will relieve the bow and allow for proper panel sidelap engagement during installation.

CAUTION

Improper and/or prolonged storage of panels may cause damage to the panel finish. Metl-Span® is not responsible for panel damage caused by improper or prolonged storage of panels.

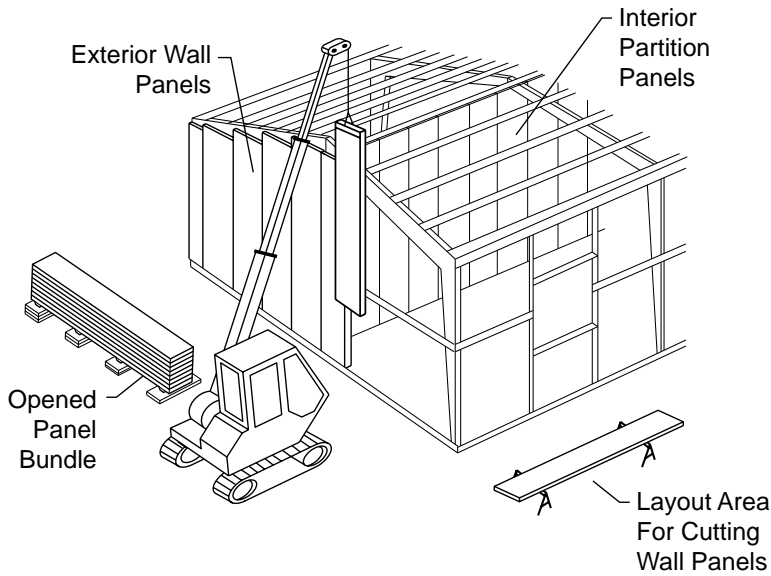

Exterior Wall Panels and Interior Partition Panels

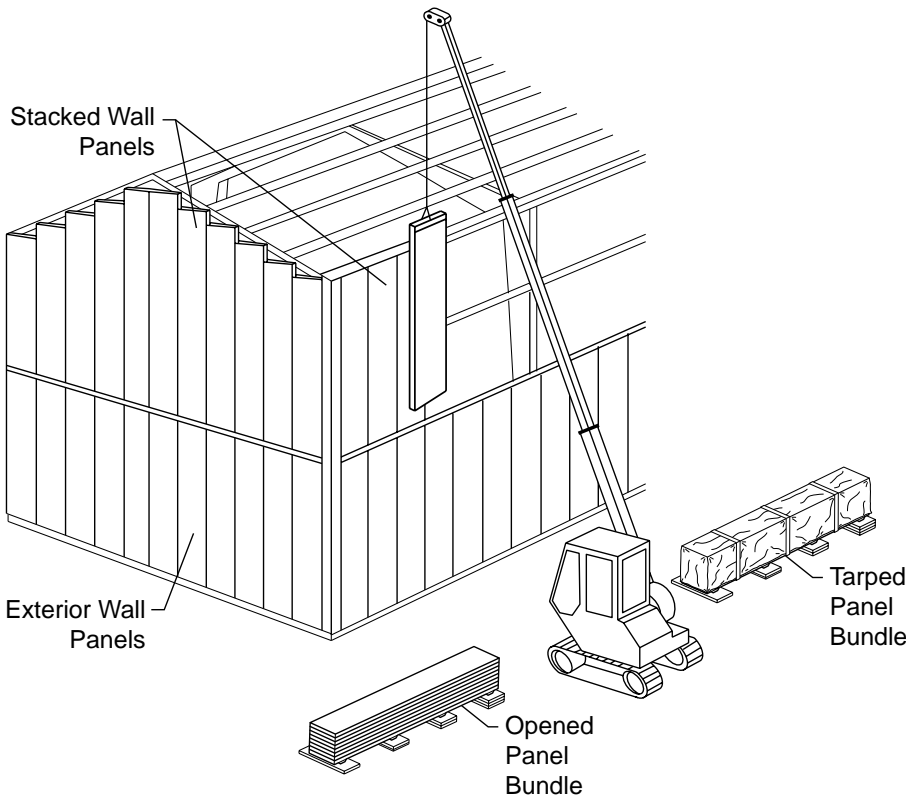

Stacked Wall Panels

PANEL STAGING (WALLS)

Each bundle of panels is shrink wrapped and marked with a bundle number at the factory. A bundle report and shipping list are included with each panel shipment. These documents provide the quantity and length of the panels within each bundle. They also provide a description of the panels such as color and gauge of the interior and exterior skins, as well as panel thickness.

These reports, in conjunction with the installation drawings, will allow the contractor to determine where each bundle of panels should be pre-positioned around the building to minimize additional bundle movement and maximize efficiencies during panel installation.

Bundles should be close to the area of the building that they will be installed on, but still allow clearance for lifting equipment and workmen during the installation process. Be sure to allow adequate space for layout and cutting of panels at corners and wall openings.

For tall walls that require stacked panels, special considerations should be made when staging panel bundles to allow room for the bottom run of panels to be completely installed before beginning installation of the next course of panels.

When present, interior partition walls may need to be installed first to allow for lifting equipment access to the interior of the building. Other options may include leaving an exterior wall partially open until the interior partition is sheathed.

GENERAL INFORMATION

LS-36™ INSULATED METAL ROOF & WALL PANEL

PACKING LIST

301 APACHE DRIVE
PO BOX 735100
JACKSON, MS 39272

SOLD TO: **107780** **SOFTAWAY CONSTRUCTION CO. LLC** JOB NAME:

DATE OF ORDER: 11-JUN-10 LOADS DATE: 29-JUL-10 CUSTOMER P.O. #: 100081300001 SHIP VIA: R & R EXPRESS SALES PERSON: R. Lloyd PG BOL NUMBER: 13655681 ORDER NUMBER: 3422723

| ITEM | DESCRIPTION | PKG | AREA | Ga | COLOR | Sheet Length | Original Order Quantity | Shipped Quantity | Remaining Quantity |
|-------|---|-----|--------|----|----------|--------------|-------------------------|------------------|--------------------|
| 1000 | EMS GRV36 2.0" EMES 26 S230 EMAS *10" | | *10* | 22 | T-SNAWHT | 24'-6-1/2" | 4 | 4 | 0 |
| 2000 | EMS GRV36 2.0" EMES 26 S230 EMAS *10" | | *10* | 22 | T-SNAWHT | 15'-3" | 6 | 6 | 0 |
| 3000 | EMS GRV36 2.0" EMES 26 S230 EMAS *10" | | *10* | 22 | T-SNAWHT | 7'-5-1/2" | 2 | 2 | 0 |
| 4000 | EMS GRV36 2.0" EMES 26 S230 EMAS *10" | | *10* | 22 | T-SNAWHT | 3'-11" | 8 | 8 | 0 |
| 5000 | EMS GRV36 2.0" EMES 26 S230 EMAS *10" | | *10* | 22 | T-SNAWHT | 3'-1" | 2 | 2 | 0 |
| 6000 | PANEL LAYOUT AT COL LN *10* EMS GRV36 2.0" EMES 26 S230 EMAS *2A" | | *2A* | 22 | T-SNAWHT | 24'-6-1/2" | 2 | 2 | 0 |
| 7000 | EMS GRV36 2.0" EMES 26 S230 EMAS *2A" | | *2A* | 22 | T-SNAWHT | 3'-11-1/2" | 1 | 1 | 0 |
| 8000 | PANEL LAYOUT AT COL LN *2A* EMS GRV36 2.0" EMES 26 S230 EMAS *3" | | *3* | 22 | T-SNAWHT | 24'-6-1/2" | 2 | 2 | 0 |
| 9000 | EMS GRV36 2.0" EMES 26 S230 EMAS *3" | | *3* | 22 | T-SNAWHT | 3'-11-1/2" | 1 | 1 | 0 |
| 10000 | PANEL LAYOUT AT COL LN *3* EMS GRV36 2.0" EMES 26 S230 EMAS *5A" | | *5A* | 22 | T-SNAWHT | 27'-1" | 8 | 8 | 0 |
| 11000 | EMS GRV36 2.0" EMES 26 S230 EMAS *5A" | | *5A* | 22 | T-SNAWHT | 10'-0" | 1 | 1 | 0 |
| 12000 | EMS GRV36 2.0" EMES 26 S230 EMAS *5A" | | *5A* | 22 | T-SNAWHT | 7'-5-1/2" | 28 | 28 | 0 |
| 13000 | EMS GRV36 2.0" EMES 26 S230 EMAS *5A" | | *5A* | 22 | T-SNAWHT | 4'-5-1/2" | 28 | 28 | 0 |
| 14000 | EMS GRV36 2.0" EMES 26 S230 EMAS *5A" | | *5A* | 22 | T-SNAWHT | 3'-1" | 20 | 20 | 0 |
| 15000 | PANEL LAYOUT AT COL LN *5A* EMS GRV36 2.0" EMES 26 S230 EMAS *12.5" | | *12.5* | 22 | T-SNAWHT | 24'-6-1/2" | 4 | 4 | 0 |
| 16000 | EMS GRV36 2.0" EMES 26 S230 EMAS *12.5" | | *12.5* | 22 | T-SNAWHT | 15'-3" | 4 | 4 | 0 |
| 17000 | EMS GRV36 2.0" EMES 26 S230 EMAS *12.5" | | *12.5* | 22 | T-SNAWHT | 7'-5-1/2" | 4 | 4 | 0 |
| 18000 | EMS GRV36 2.0" EMES 26 S230 EMAS *12.5" | | *12.5* | 22 | T-SNAWHT | 3'-11" | 8 | 8 | 0 |
| 19000 | EMS GRV36 2.0" EMES 26 S230 EMAS *12.5" | | *12.5* | 22 | T-SNAWHT | 3'-1" | 4 | 4 | 0 |
| | PANEL LAYOUT AT COL LN *12.5" | | | | | | | | |

page 1 of 3

PANEL STAGING (ROOF)

Each bundle of panels is shrink wrapped and marked with a bundle number at the factory. A packing list is included with each panel shipment.

The list provides the quantity and length of the panels. It also provides a description of the panels such as color and gauge of the interior and exterior skins, as well as panel thickness.

The bundle tags and packing list, in conjunction with the installation drawings, will allow the contractor to determine where each bundle of panels should be pre-positioned around or on the building to minimize additional bundle movement and maximize efficiencies during panel installation.

Bundles should be close to the area of the building that they will be installed on, but still allow clearance for lifting equipment and workmen during the installation process.

If bundles are to be set onto the roof, care must be taken not to overload the primary or secondary structurals. Bundles should be laced over the rafters. If the secondary structurals are purlins, they should be temporarily braced to prevent them from rolling. On steep slopes, provision must be made to prevent panels from sliding off of roof.

Make sure panels are oriented for proper installation direction. Always consult the engineer of record to determine safe load capacities of the structural framework.

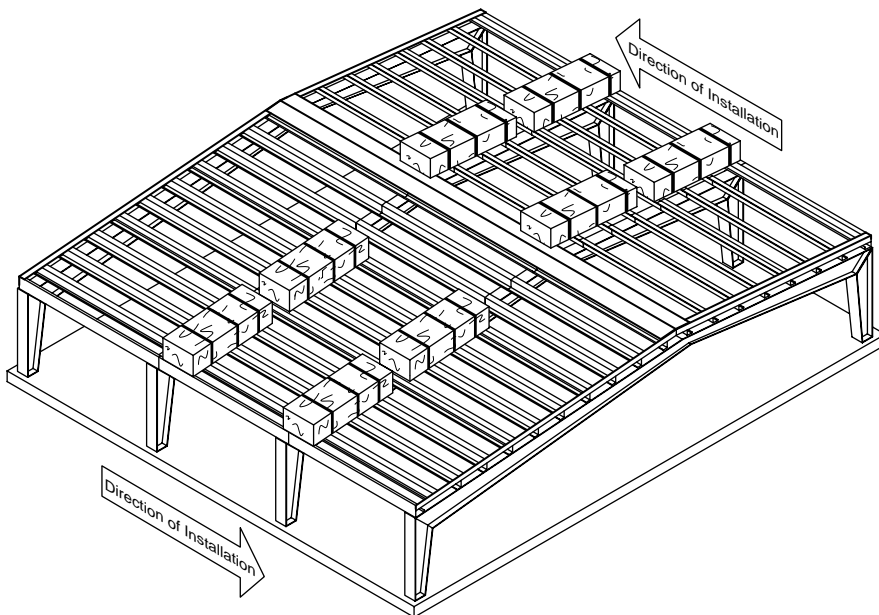

Staged Roof Panels

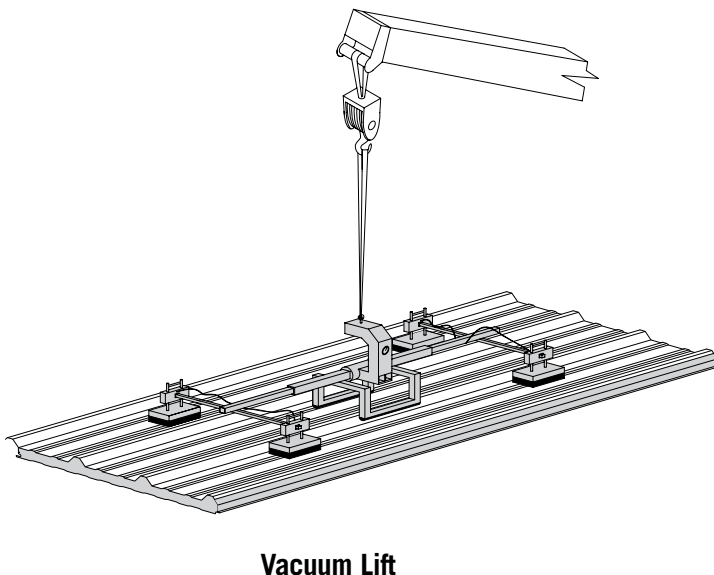
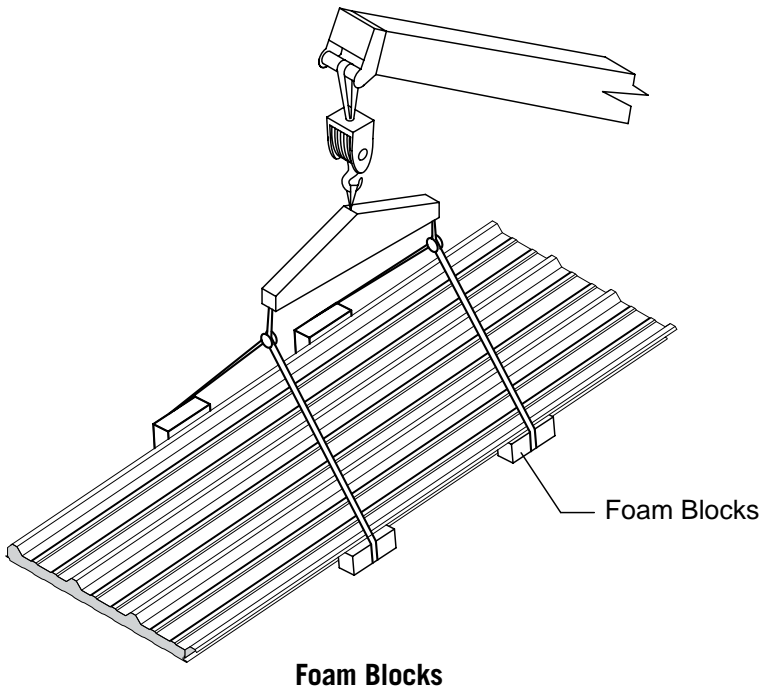
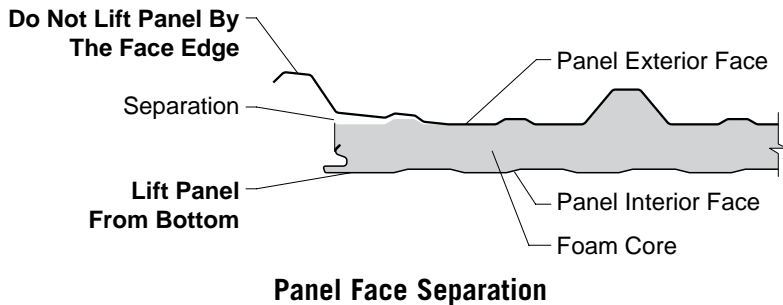

HANDLING PANELS DURING INSTALLATION

It is important to protect the panels during the installation process. Because of their weight, the panels have considerable inertia, which makes them susceptible to impact damage while moving them.

Always protect exposed panel surfaces from damage caused by temporary supports, lifting slings or clamps.

Do not slide panels across rough or abrasive surfaces. Do not set panels on sharp or irregular surfaces as this may dent the bottom face of the panel.

Lift panels from the bottom face only. **Do not lift panels by the edge of the top face; this will cause the metal face to separate from the foam core.**

It is the contractor's responsibility to ensure that the lifting equipment is sufficient for the job and that the methods employed are safe.

Panels may be lifted with nylon slings or with vacuum equipment. When using slings, spacer blocks must be installed along edges to prevent damage during lifting. Note that foam spacer blocks must be placed under female leg and be wide enough to where strap will not crush panel. The slings or vacuum equipment must be properly spaced to prevent panel buckling.

CAUTION

While lifting equipment may safely lift a panel under static conditions, wind forces or inertia forces caused by jerky boom operation or transit across rough terrain, may exceed the equipment's capacity, causing injury to workers and/or material damage.

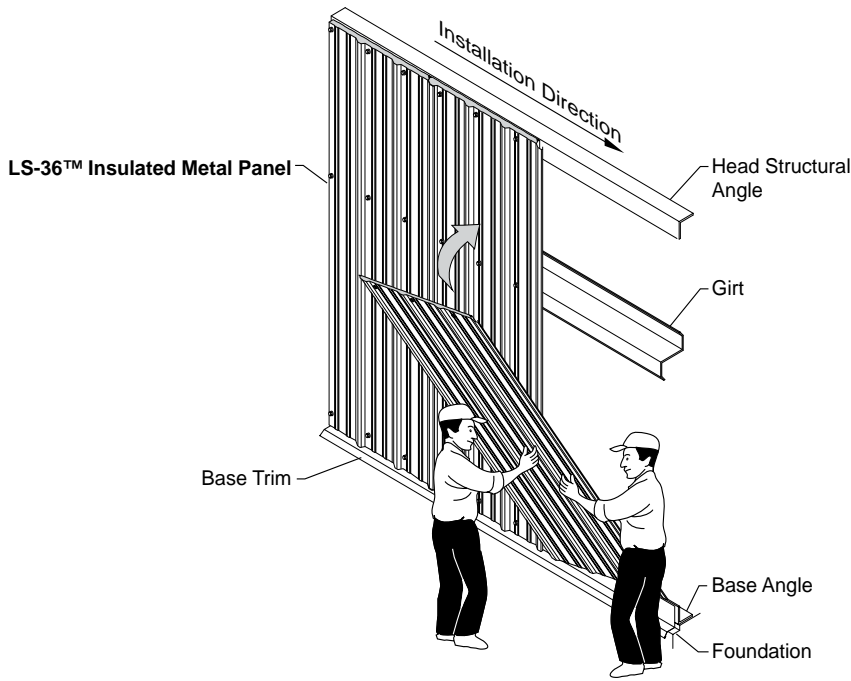

Manual Panel Setting

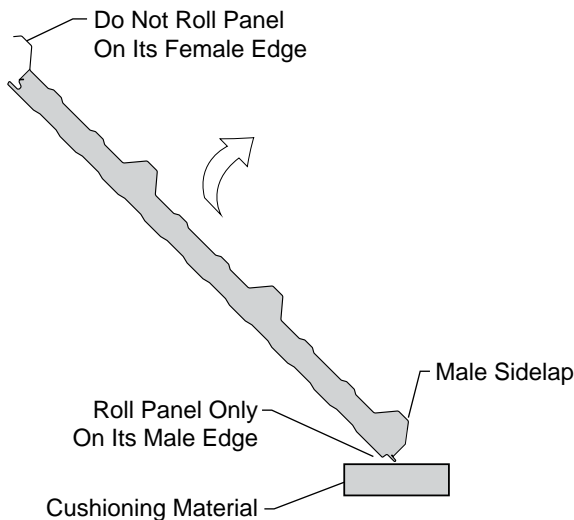

Panel Rotating

HANDLING PANELS DURING INSTALLATION (continued)

Manual Panel Installation

Improper handling of the panels can be hazardous to the workers and can cause damage to the panels and adjacent materials. It is the contractor's responsibility to provide an adequate work force to safely carry and raise panels into place.

When panels are to be turned over or tilted up on edge, place a cushioning material under the panel edge to prevent crushing or damage to the panel finish. Roll onto male leg of panel only.

Before raising a panel into place, make sure the interior face is turned upward and the male sidelap is on the side of the panel coinciding with the installation direction. Move the panel to the building and set the bottom end of the panel at the base.

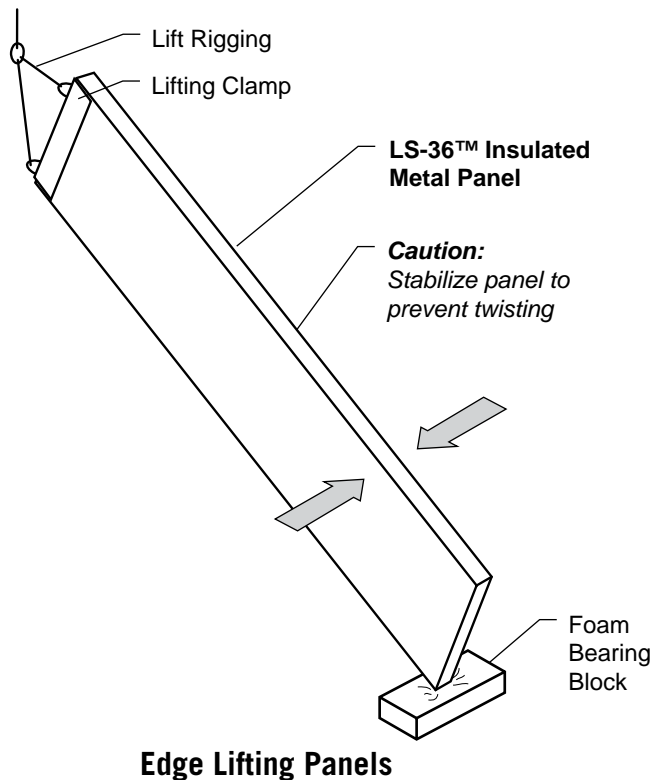
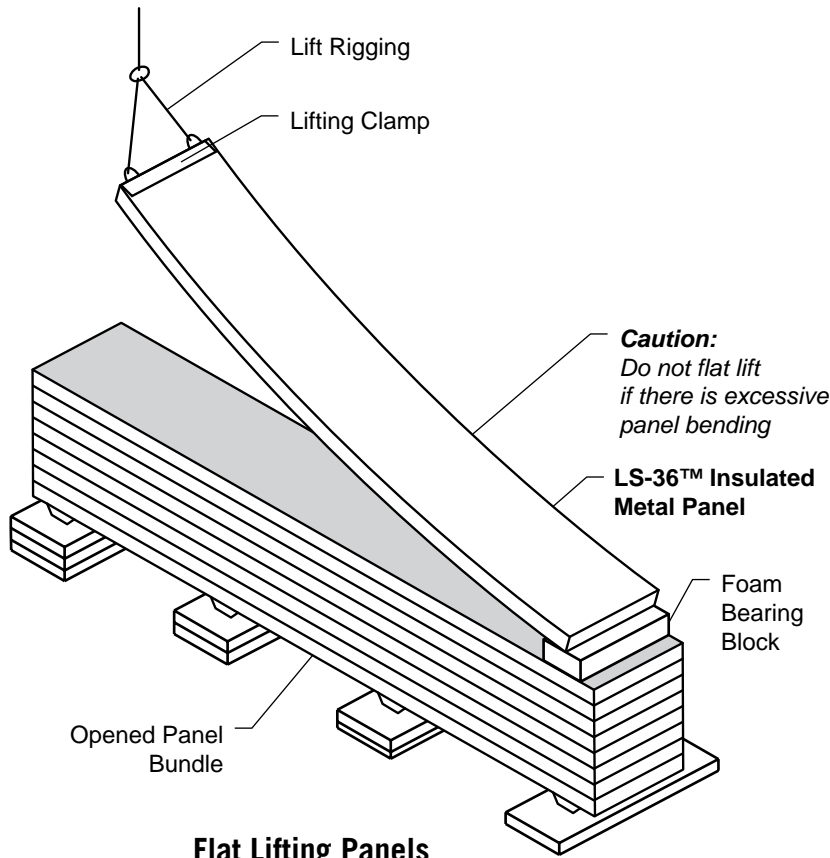

HANDLING PANELS DURING INSTALLATION (continued)

It is important to protect the panels during the installation process. Because of their weight, the panels have considerable inertia, which makes them susceptible to impact damage while moving them.

Setting Panels With A Crane

It is the contractor's responsibility to ensure that the lifting equipment is sufficient for the job and that safe methods are employed. This includes ensuring that the clamp referred to below is of suitable design and condition to safely lift the panels without a failure of the lifting connection or damage to the panel.

When flat lifting panels with a crane, a clamp or hook is attached to the top end of the panel. The panel is then lifted to the vertical position and moved into place at the wall. The clamp or hook is removed and the panel secured to the structure. To prevent damage to other panels in the bundle, place a bearing pad (rigid foam works well) between the bottom end of the panel being lifted and the next panel in the bundle.

Before attempting to flat lift panels, make sure the panels can be lifted without causing excessive bending or buckling. Longer panels may require edge lifting.

HANDLING PANELS DURING INSTALLATION (continued)

Setting Panels With A Crane

Edge lifting involves clamping or hooking the panels as before, but requires that the panel be rolled up on its edge before being lifted into the vertical position. This technique will require a bearing pad to protect the panel edge as it is rolled onto the male edge. It will also require that a sufficient number of workers stabilize the panel as it is being lifted into the vertical position to prevent it from twisting. The panel is then raised vertically and set into place as before.

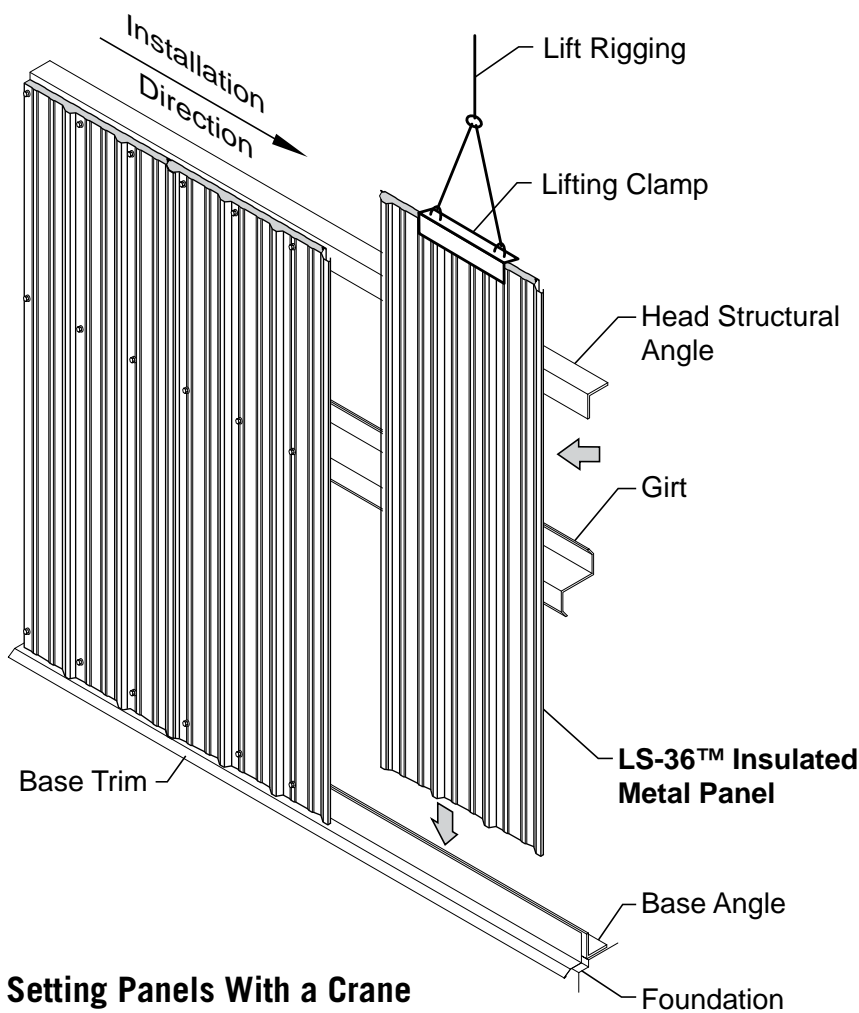

Setting Panels With a Crane

CAUTION

While lifting equipment and lifting clamps may safely lift a panel under static conditions, wind forces and inertia forces caused by jerky boom operation or transit across rough terrain may exceed the equipment's and/or clamp's capacity, causing injury to workers and/or material damage.

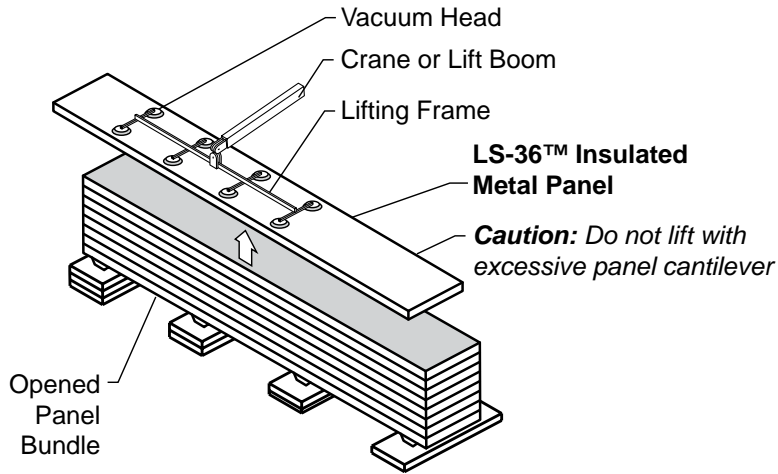

Lifting Panels With Vacuum Lift

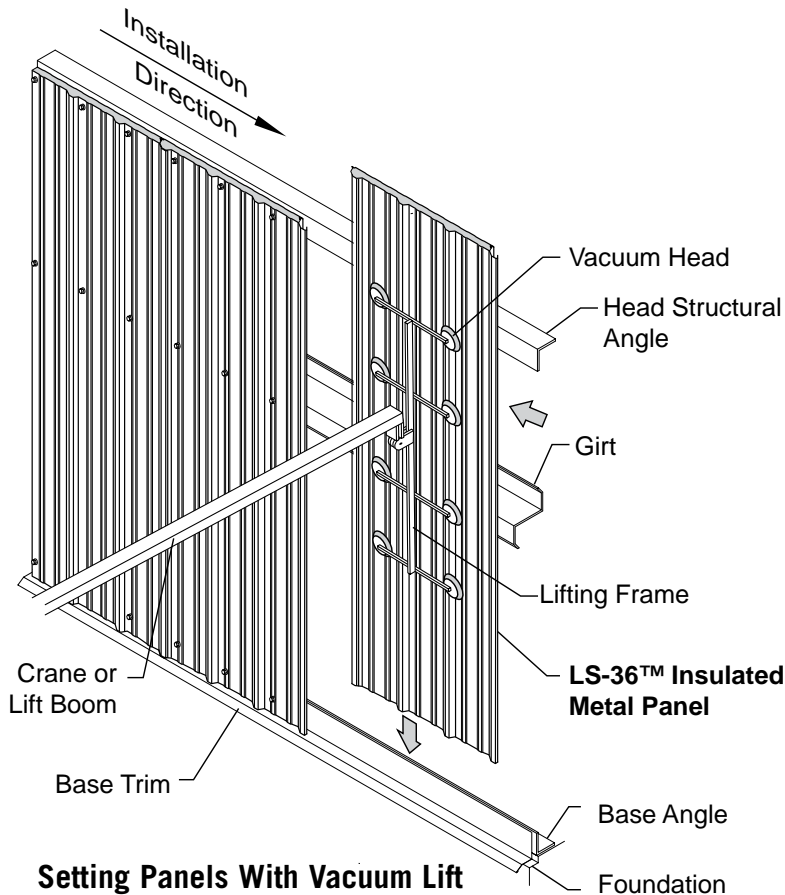

Setting Panels With Vacuum Lift

HANDLING PANELS DURING INSTALLATION (continued)

Setting Panels With A Vacuum Lift

Improper handling of the panels can be hazardous to the workers and can cause damage to the panels and adjacent materials. It is the contractor's responsibility to ensure a safe and secure method of lifting and setting the panels.

When using vacuum lift equipment, there should be no holes or clamps to damage the panels. There is also no equipment on the inside surface of the panel to foul on the structural framing during panel installation, allowing panels to be secured to the structure while the vacuum lift is holding them in place.

With a properly sized vacuum unit, the multiple vacuum heads provide uniformly spaced pick-up points to minimize potential bending or buckling of panels as they are lifted from the bundle and set into place.

The contractor must verify that the lifting equipment is of sufficient capacity for the panel weight and length and is of sufficient mobility and reach for site conditions. The contractor must also verify that the vacuum heads are of suitable design and condition to safely lift the profiled and embossed surfaces of the panels. Special vacuum heads will be required for the minor ribs in the LS-36™ Insulated Metal Panel.

CAUTION
While the vacuum heads may safely lift a panel under static conditions, wind forces and inertia forces caused by jerky boom operation or transit across rough terrain, may exceed the equipment's capacity, causing injury to workers and/or material damage.

LS-36™ Insulated Metal Panel WALL PANEL ORIENTATION

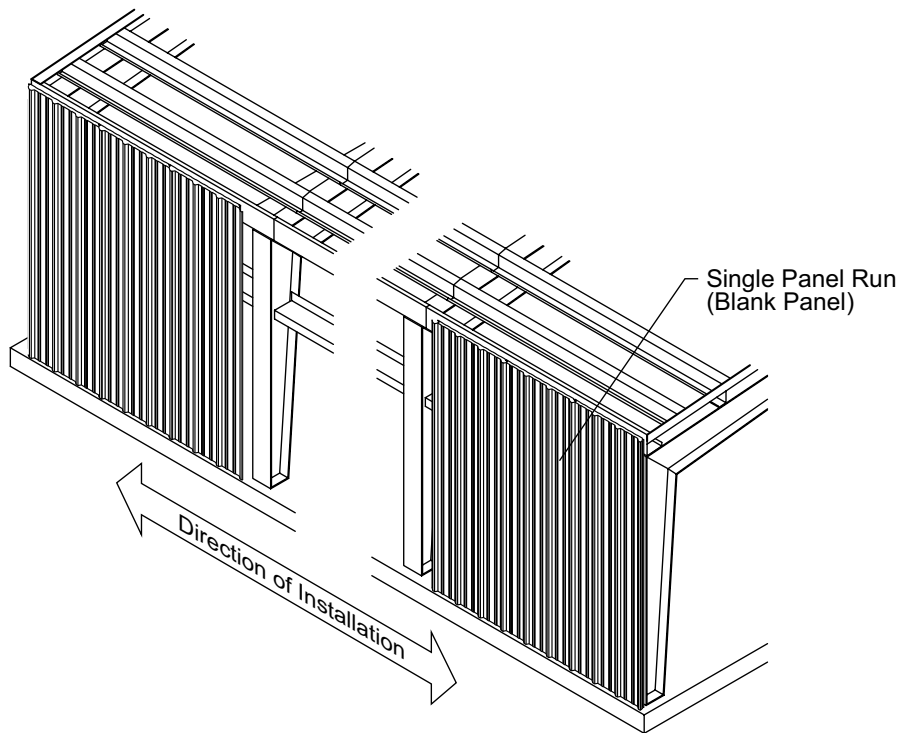

Single Run Wall Panels

Panels May Be Erected From Either Direction

Blank Panel One Panel From Base To Eave



Blank Panel Is
Square Cut Both Ends

LS-36™ Insulated Metal Panel WALL PANEL ORIENTATION

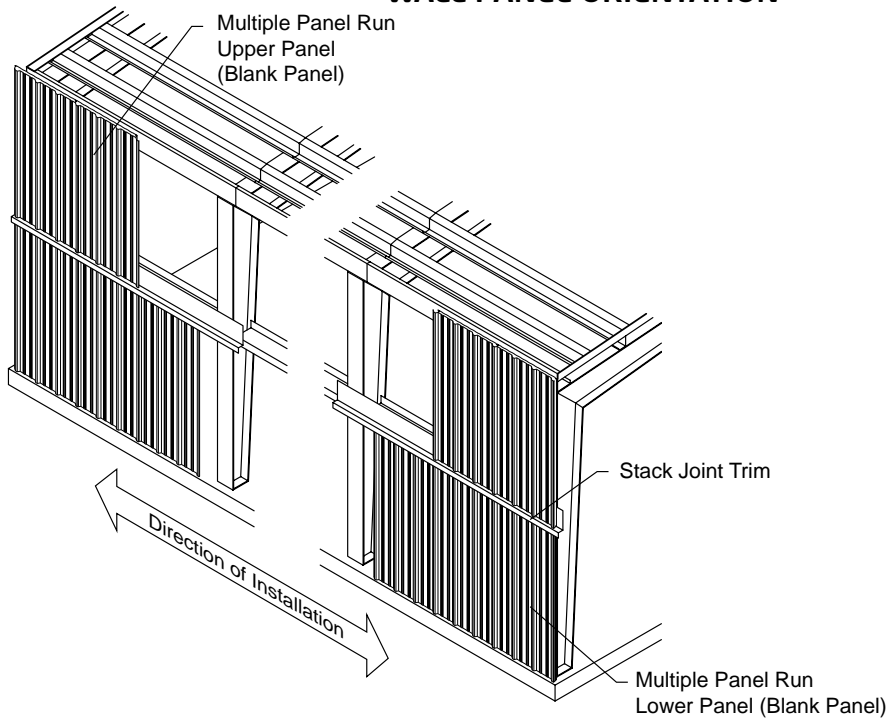

Stack Joint Wall Panels With Trim

Panels May Be Erected From Either Direction

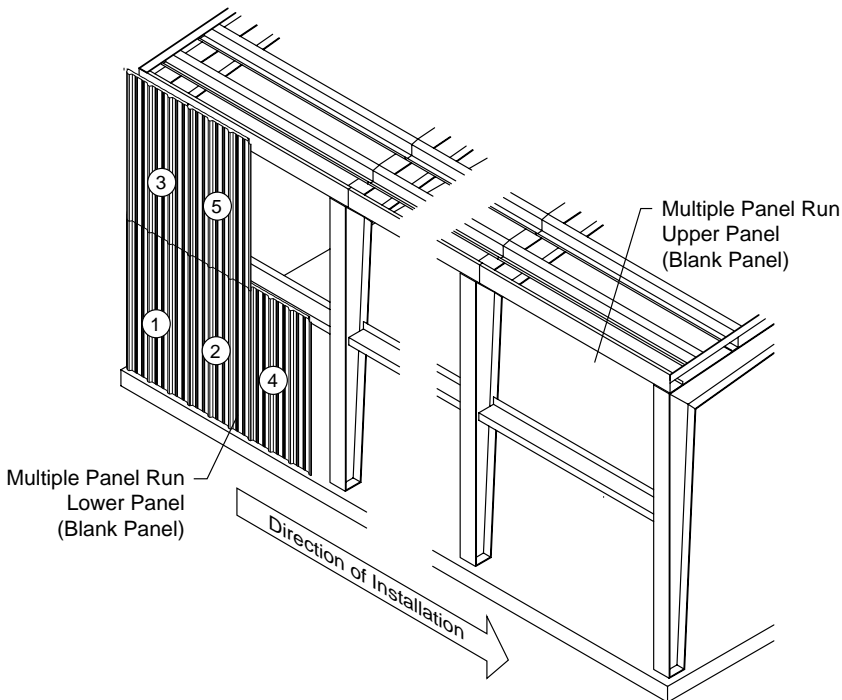

Stack Joint Wall Panels Without Trim

Panels Must Be Erected From Left To Right

Blank Panel
One Panel From Base To
Stack Joint Trim And From
Stack Joint Trim To Eave

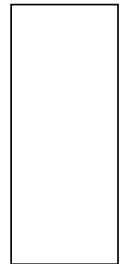

Blank Panel Is
Square Cut Both Ends

Lap Panel
Multiple Panels From
Stack Joint To Stack Joint
Or To Eave

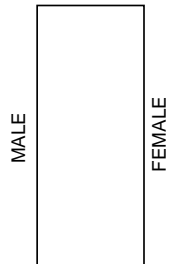

3" Cutback

Blank Panel
One Panel From Base To
Stack Joint

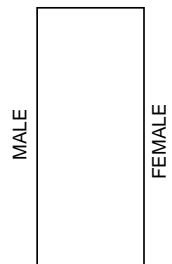

Blank Panel Is
Square Cut Both Ends

WALL PANEL - FASTENER PATTERNS

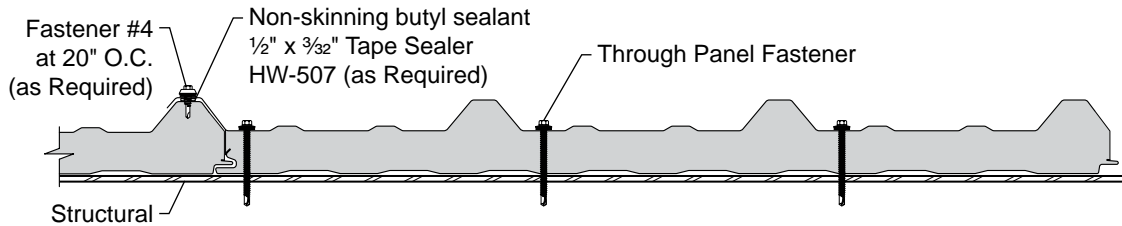

Fastener Pattern at Base, Intermediate and Head Structurals

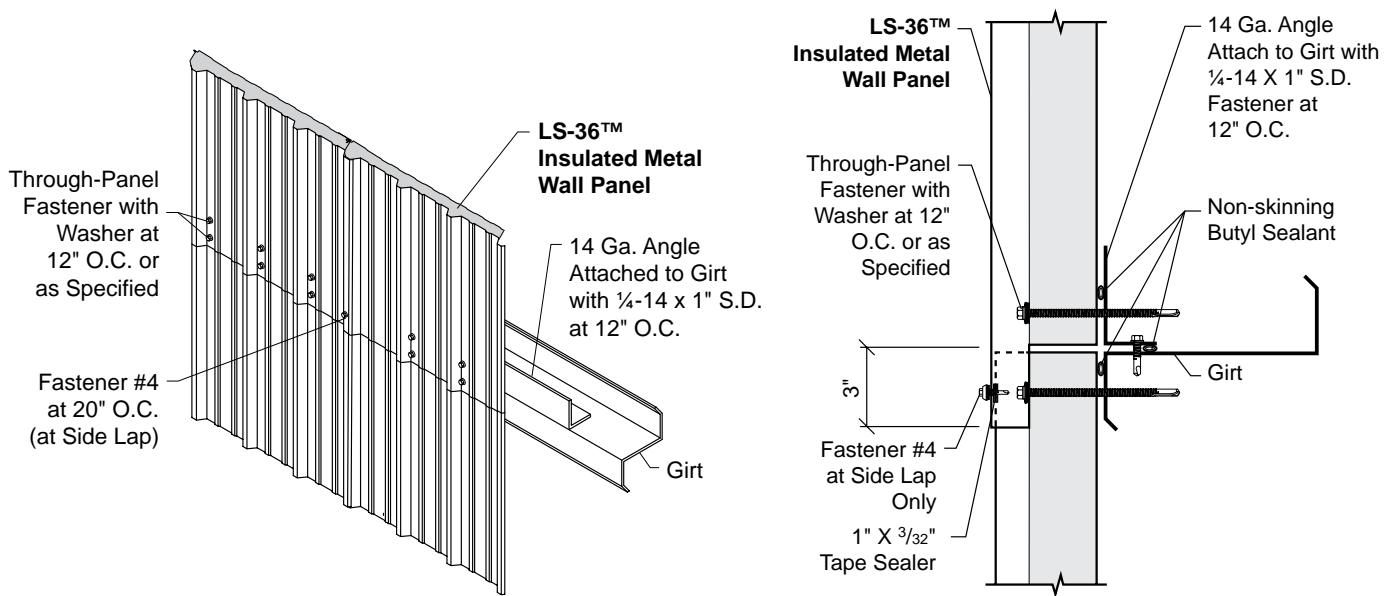

Fastener Patterns at Wall End Lap

NOTES:

1. The above are typical fastener spacings. However, they may not be appropriate for all applications. Consult a professional engineer for use on any specific application.
2. Minimum 3/8" Bead of Non-Skinning Butyl Sealant required at panel side laps when exterior vapor seal is required.
3. Side lap fasteners are required. Typical spacing is 20" O.C. However, this spacing may not be appropriate for all applications. Consult a professional engineer for use on any specific application.

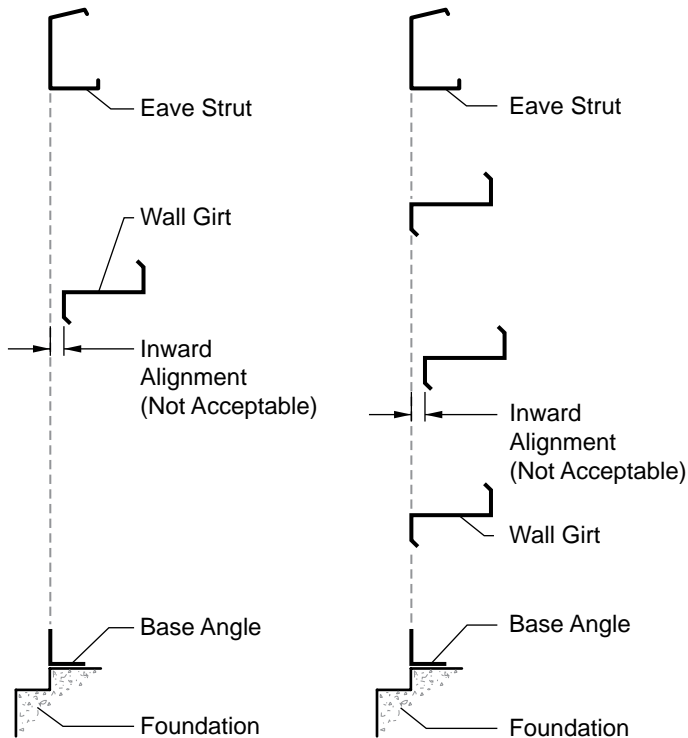

Unacceptable Alignment

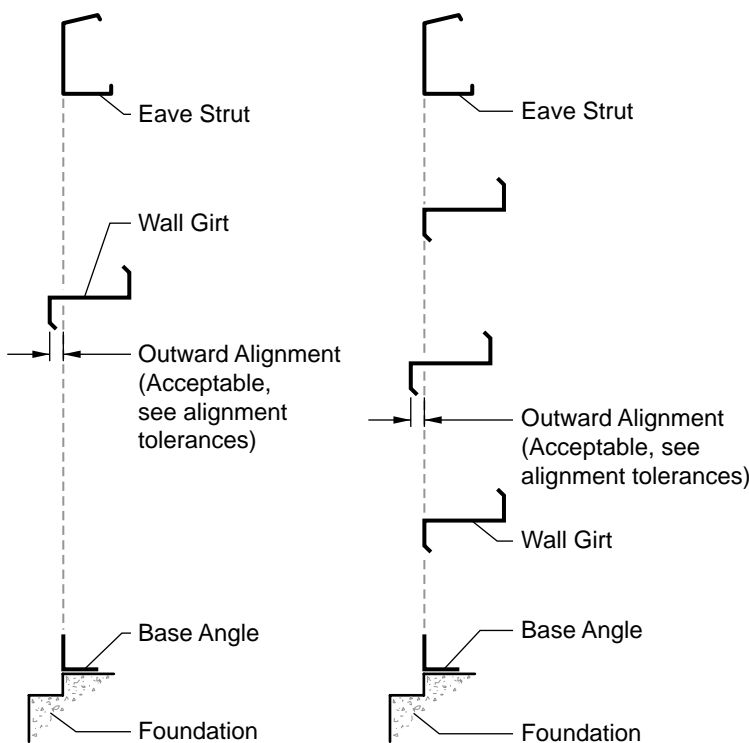

Acceptable Alignment

PREPARATORY REQUIREMENTS

Before beginning installation of wall panels, verify that all structural framing and bracing has been installed and that all connection bolts have been installed and tightened.

Check each wall to ensure that the steel framing is plumb and that it is “in plane” from top to bottom. Check substructure at each column location and at mid-span of each bay. An out-of-plane substructure will force the panels to bend when the panel clip fasteners are installed causing oil canning and difficulty engaging the next panel. Tolerances for substructure alignment are as follows:

- General tolerance is $L/300$, though the substructure must not allow installed panels to bow inward of the steel line.
- 10' girt spacing – $\frac{1}{4}$ " out-of-plane tolerance (**Outward Only**)
- Less than 10' girt spacing – $\frac{1}{8}$ " out-of-plane tolerance (**Outward Only**)

CAUTION

Diaphragm capabilities, seismic bracing and girt stability are not provided by Metl-Span® LS-36™ Insulated Metal Wall Panels. Therefore, other bracing may be required to conform to A.I.S.C. or A.I.S.I specifications.

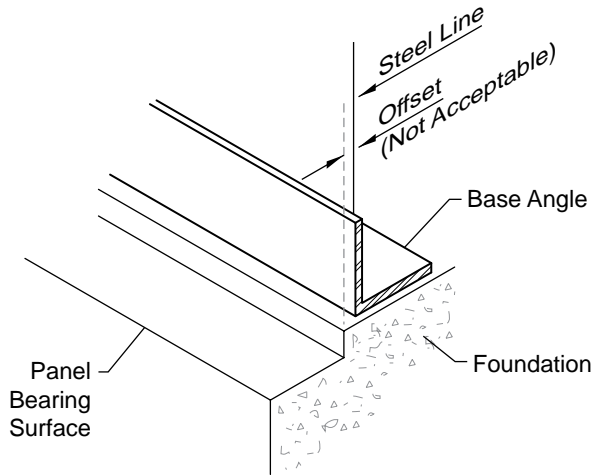

Unacceptable Alignment at Foundation

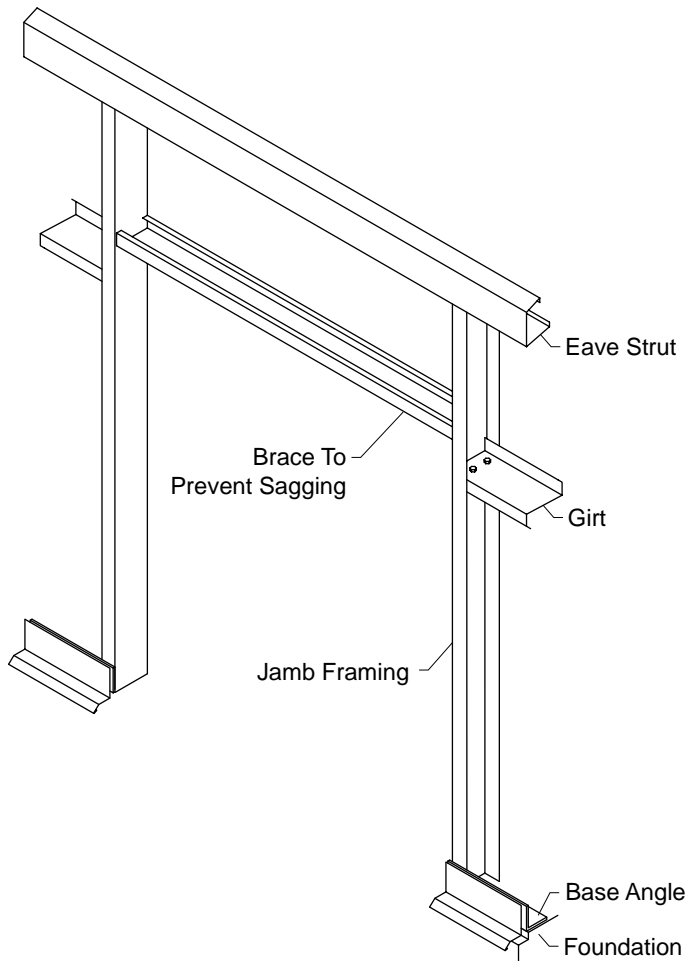

PREPARATORY REQUIREMENTS (continued)

When installing the base angle, do not allow it to be inset from the concrete edge. Where the concrete sheeting is notched incorrectly, it is better to allow the base angle to overlap the concrete edge than to have the concrete finished floor extend outward of the base angle. Allowing this condition will cause the panels to bow inward at these locations, which could result in oil canning.

When panels are not supported by the foundation, such as at large door or window openings, the girts above these openings must be temporarily braced to prevent sagging while panels are being attached to the structure.

**PREPARATORY REQUIREMENTS
(continued)**

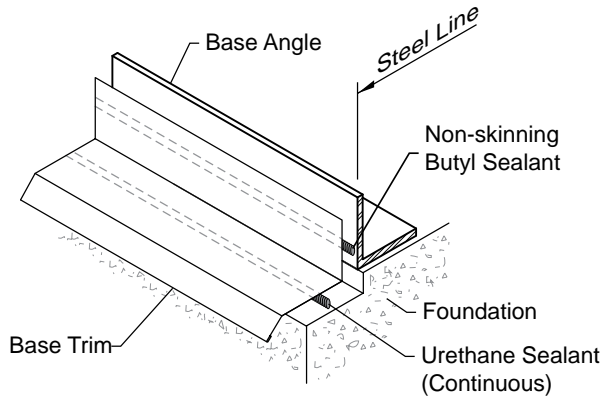

Base Assembly With Sheeting Notch

Seal base flashing to sheeting notch and attach to the foundation at the specified spacing.

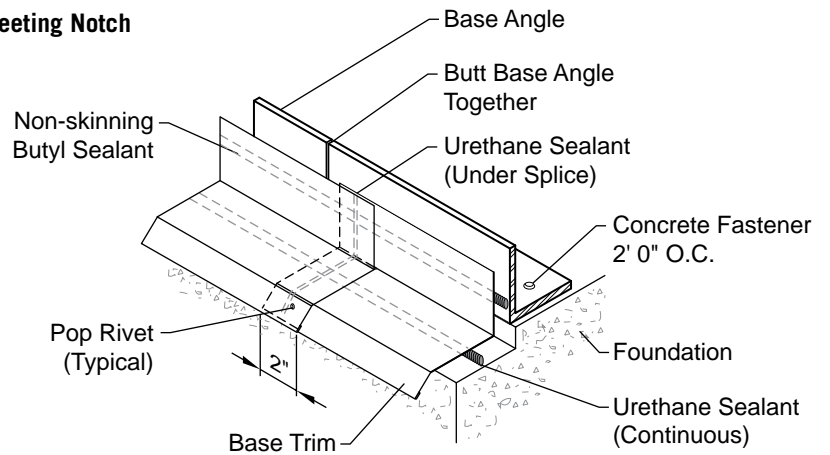

Base Assembly Trim Splice

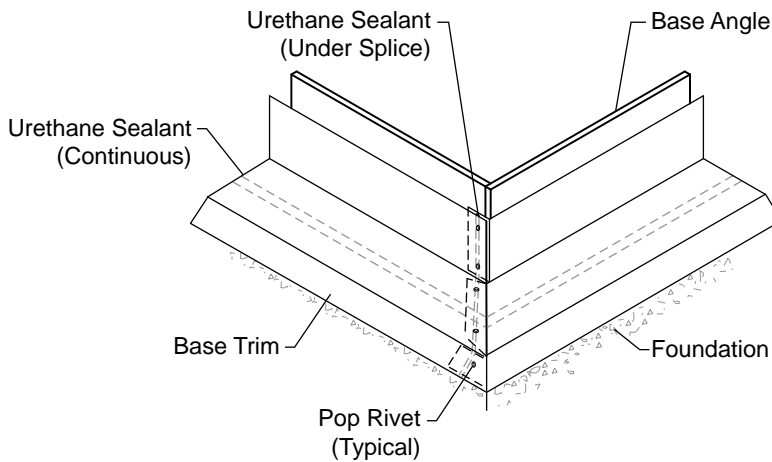

Base Corner Miter Assembly

Seal base flashing joints with urethane sealant. At corners, miter the base flashing, seal with urethane sealant and rivet together.

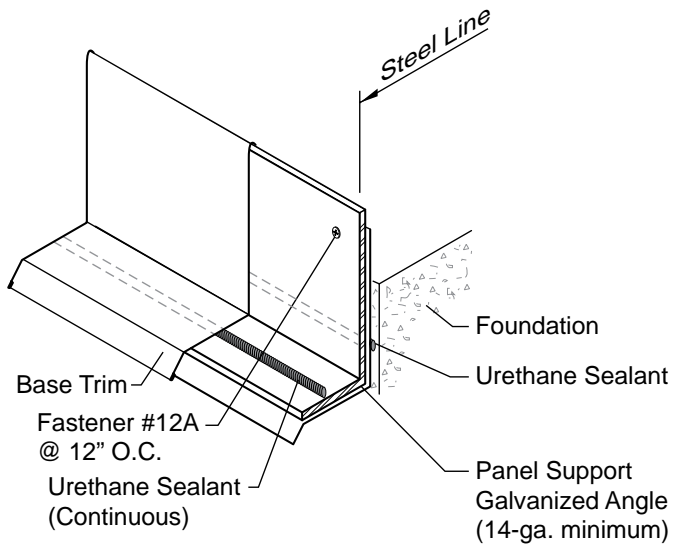
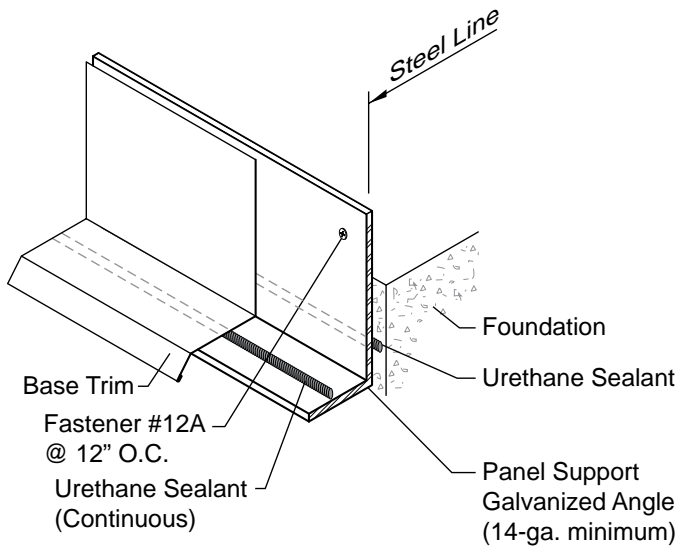

Base Assembly Without Sheeting Notch

**PREPARATORY REQUIREMENTS
(continued)**

Seal the support angle to the concrete with a continuous run of urethane sealant.

Install a continuous run of urethane sealant between the horizontal leg of the support angle and the base trim.

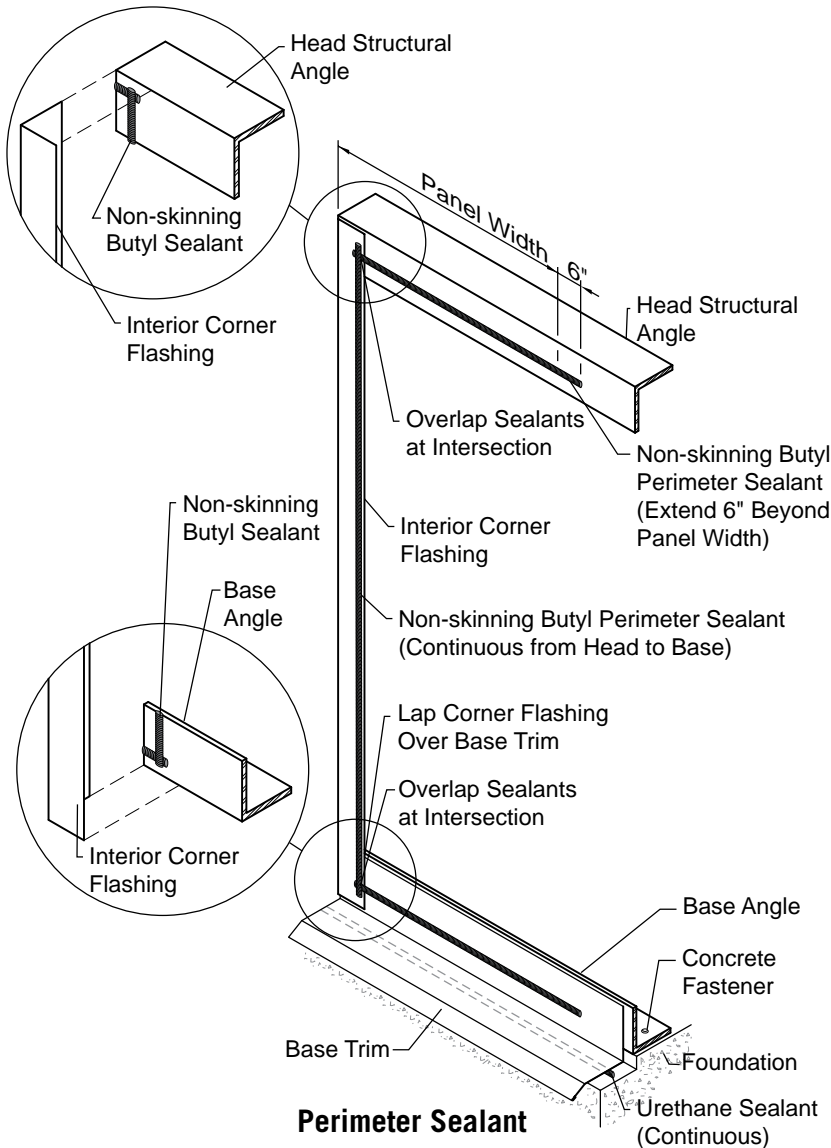

Perimeter Sealant

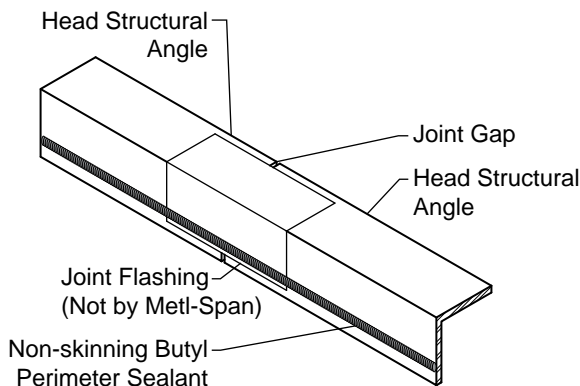

Sealing Structural Joints

PREPARATORY REQUIREMENTS (continued)

Before wall panels are installed, ensure that all applicable interior trim that may be required at corners or door and window openings, is installed as shown on the project drawings.

Install non-skinning butyl sealant where corner trim overlaps base trim or head structural.

Any areas that require a sealant bead for a vapor seal must be continuous. If the seal is made to the structure and not to trim, make sure there are no gaps in the structural framing. Cover any gaps with a piece of joint flashing.

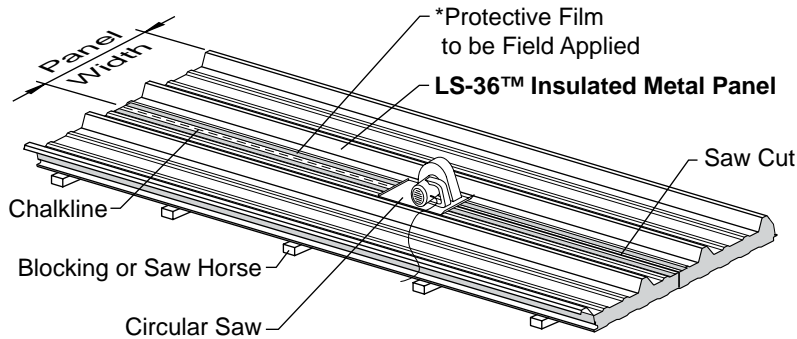

Cutting Panels

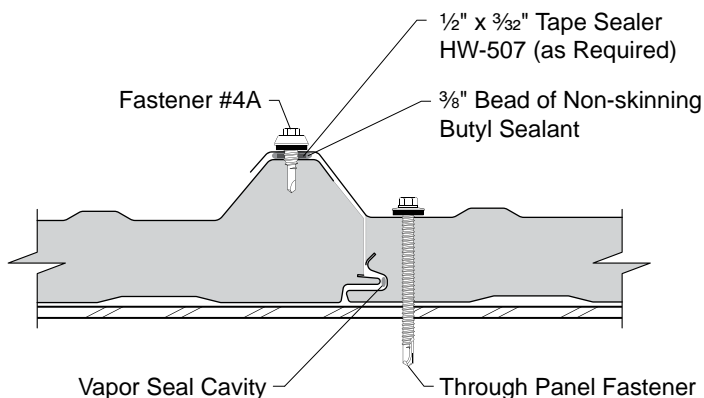

Assembled Side Joint

*Protective Film is not by Metl-Span

PREPARATORY REQUIREMENTS (continued)

Panels can be cut with a circular saw using a metal cutting blade. Do not use an abrasive blade. An abrasive blade will melt the Galvalume® or Galvanized coating causing rust problems. It may be necessary to cut thicker panels on both sides. Properly support the panel during cutting. Protect against scuffing the panel finish from the shoe of the saw or from sliding the panel on the supports. **Blade must cut cool and not melt coating or finish.**

Inspect each panel for damage before installing. Replacement of installed damaged panels is difficult and costly. Remove all metal filings immediately after cutting panel to prevent surface rust.

When panel joints are fully engaged, the coverage may vary $-\frac{1}{16}$ " to $+\frac{1}{8}$ " due to panel tolerances.

Panel module should be checked at the eave ridge and each endlap. Checking and adjusting the module often will help keep the roof straight. Never adjust the module of any panel more than $\frac{1}{16}$ " as this could prevent adjacent panels from sealing to each other, which may allow condensation to form in the panel joint.

NOTE

When vapor seal is required at exterior side of panel, apply $\frac{3}{8}$ " bead of Non-skinning Butyl Sealant to panel side lap.

WALL LAYOUT

It is recommended that the wall panels be installed so panels at each corner are the same dimension. This will provide a symmetrical wall and result in a more aesthetically pleasing appearance.

Measure the actual wall to account for any field tolerances. Divide the length of the wall by the panel width. Then divide the remainder by 2. If this dimension is less than half of the panel width, add one panel width to the remainder and then divide by 2. For example, if a wall is 100'-6" long, convert to inches (1206) and divide by the panel width, 36" for example (1206/36), which equals 33 full width panels with 6" left. Divide 6" by 2, which equals 3". Since 3" is less than $\frac{1}{2}$ of the panel width (36"), add 36" to 6" and divide by 2, which equals 21". In this example, the corner panels would be cut to 21" wide, which results in the use of 32 full width panels. If beveled corner is to be used, add the panel thickness for the final cut width.

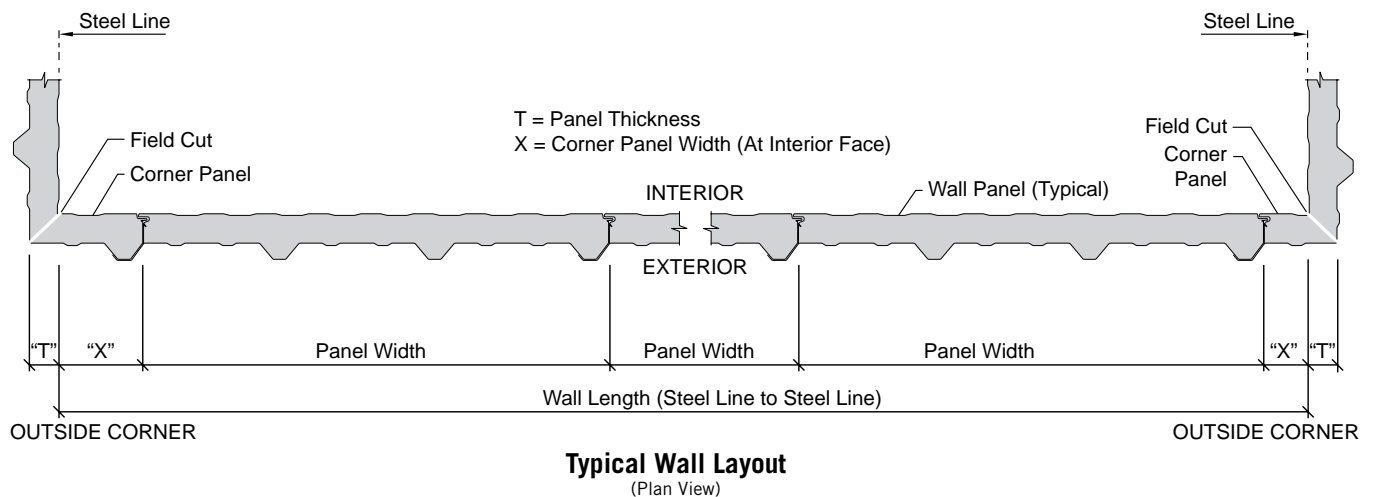

Note: Follow Metl-Span® shop drawings if there is a difference.

CAUTION

TO ALLOW FOR FIELD INSTALLATION TOLERANCES, DO NOT CUT THE ENDING CORNER PANEL UNTIL THE REST OF THE WALL PANELS HAVE BEEN INSTALLED. AT THAT TIME, MAKE A FINAL MEASUREMENT TO ENSURE THAT THE ENDING PANEL IS CUT TO THE RIGHT WIDTH.

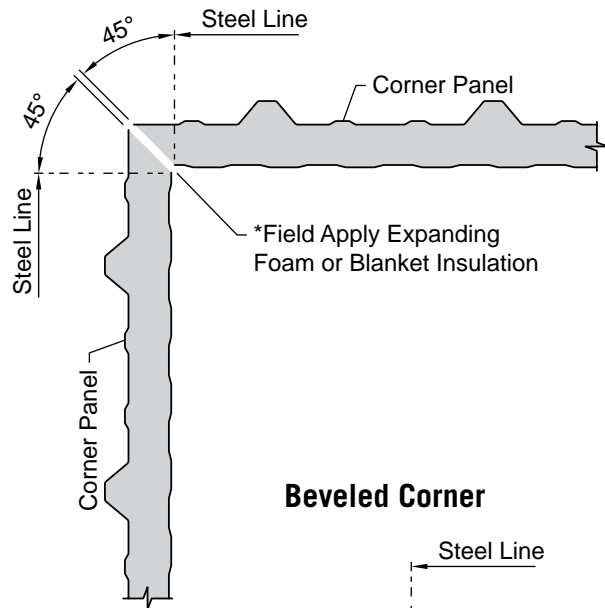

Beveled Corner

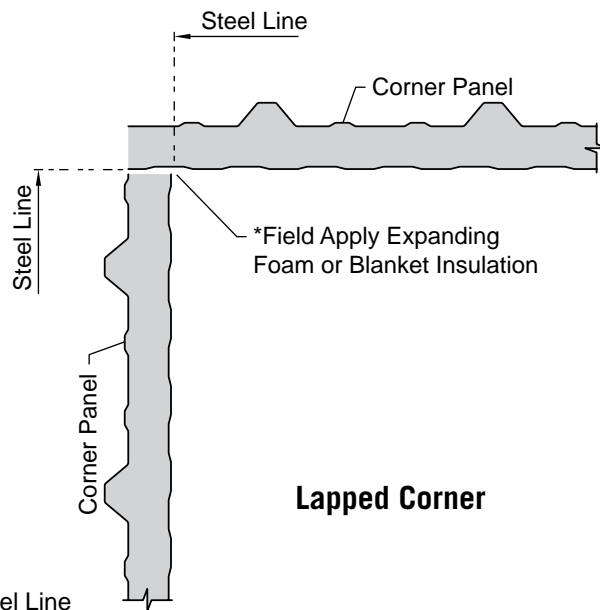

Lapped Corner

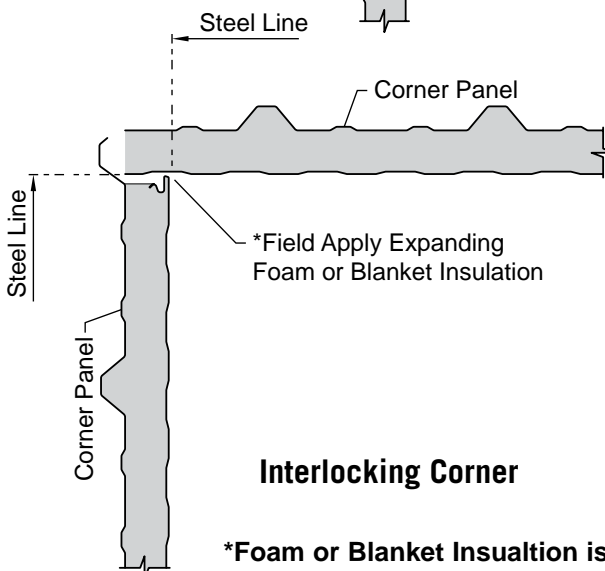

Interlocking Corner

*Foam or Blanket Insulation is not by Metl-Span

**WALL LAYOUT
(continued)**

There are several ways in which the panels at the corners can be cut:

Beveled Corners

The edges of the corner panels are cut on a 45-degree angle and are butted together at the corner.

Lapped Corners

The edges of the corner panels are square cut with the panel on one wall extending past the end of the other panel, forming the lap joint.

Interlocking Corners

One panel at the corner is full width and stops at the steel line. The other panel is cut to extend past the full width panel to complete lap joint.

NOTE

Install expanding foam or blanket insulation in all voids.

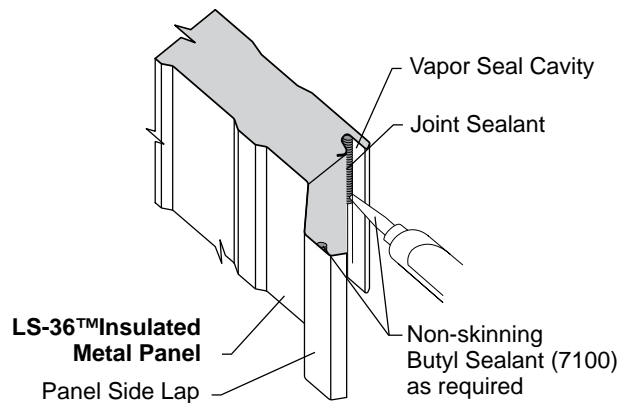

Field Applied Joint Sealant

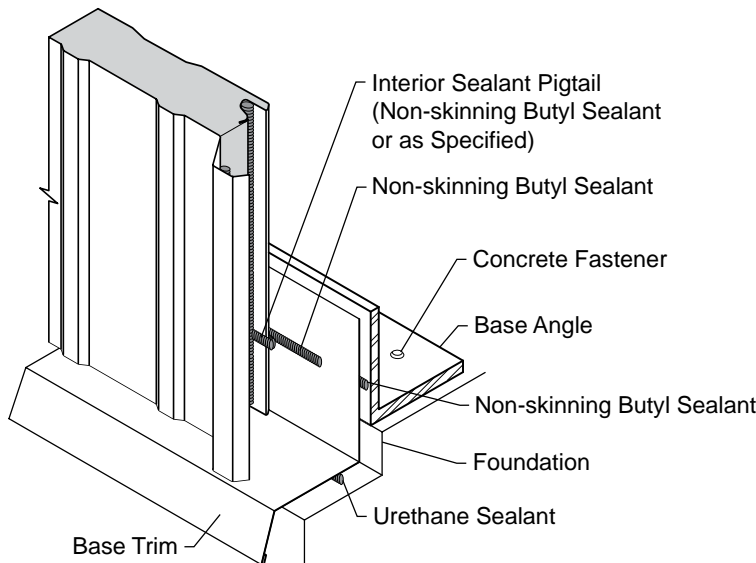

Sealant Pigtail at Base

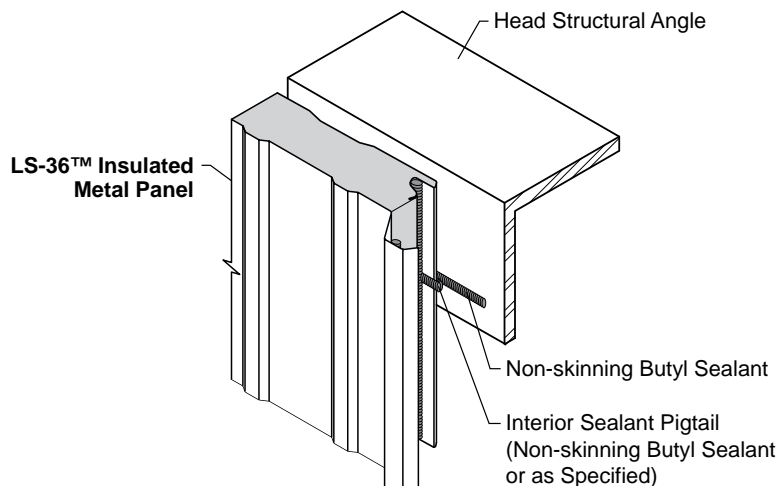

Sealant Pigtail at Head Joint

PANEL SEALANT REQUIREMENTS

Depending upon project requirements and how the panels were ordered, field-applied sealant may be required in the vapor seal cavity of the panel. If the panels were ordered with factory mastic, then field-applied side joint sealant will not be required. **However, factory-applied mastic must be inspected to ensure it is undamaged and continuous. Repair with field-applied sealant as necessary.** If the panels were ordered without factory mastic, a non-skinning butyl sealant must be field applied if required. Consult the project drawings to determine if the vapor seal cavity or the panel side lap is to receive the sealant. On some projects, different walls may have different requirements.

When required, the field-applied sealant must be applied continuously into the vapor seal cavity. The bead size should be approximately 1/4" to 3/8". However, adjust the bead size to provide full contact with the tongue of the next panel without extruding sealant onto the interior panel face.

It is critical to ensure continuity of the sealant line at intersections between panel side joints and exterior and interior perimeter flashing assemblies. As each panel is installed, apply sealant pigtails around the panel's interior tongue to provide a continuous seal between the interior side joint groove and the perimeter sealant.

At the exterior face of the panel, determine where the exterior flashing sealants will be located. Apply a sealant pigtail around the panel's interior tongue to provide a continuous seal between the exterior side joint groove and the exterior flashing.

CAUTION

Failure to provide a continuous seal at the panel side joint and all perimeter trim conditions may lead to condensation inside the building and/or inside the panel joints.

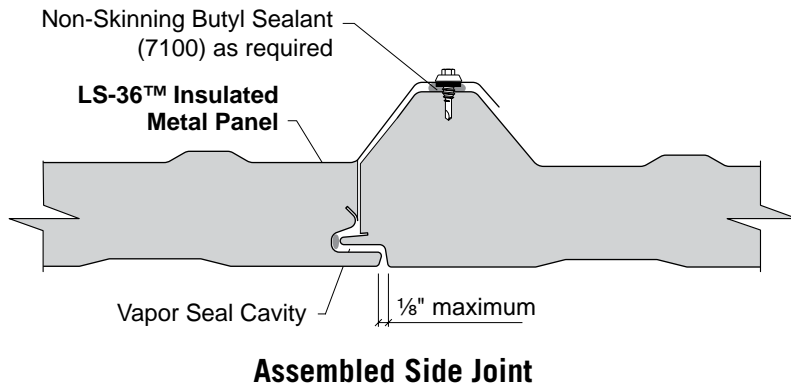

Assembled Side Joint

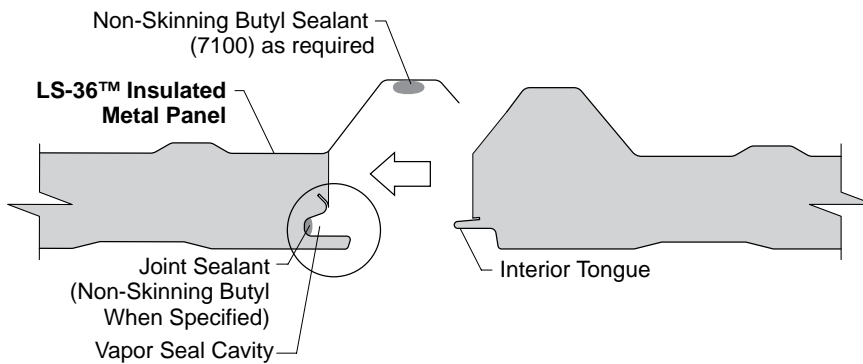

Joint Sealant Application

PANEL JOINT ENGAGEMENT

Proper panel engagement is critical to the performance and appearance of the wall panels. When the panels are fully engaged to one another, the actual panel width may vary by up to 1/8" due to manufacturing and field tolerances.

Consult the project drawings for the proper type and number of fasteners to be used at each framing member.

If panels were not ordered with factory applied mastic, ensure that field applied mastic is installed as required before installing the next panel.

CAUTION

Do not overtighten fasteners to a point that damages or deforms the panel.

NOTE

Vapor sealant locations must be determined by the appropriate engineer for proper application of panel system.

WALL INSTALLATION

LS-36™ INSULATED METAL ROOF & WALL PANEL

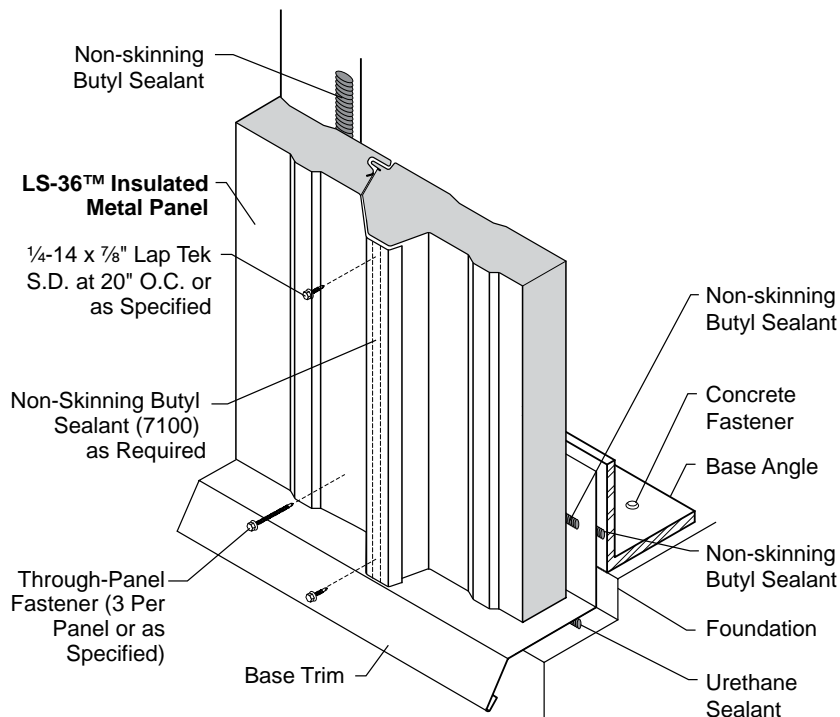

Panel Attachment at Base

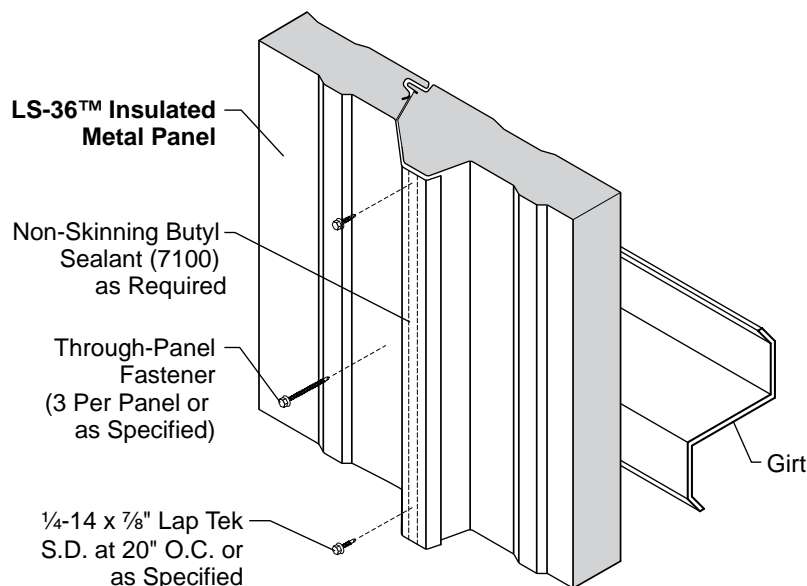

Panel Attachment at Intermediate Support

BASE

At the base, make sure the base trim has been installed and fully sealed to the concrete. Also, confirm that the perimeter sealant (non-skinning butyl sealant) has been installed along the vertical leg of the base trim at least 6" beyond the panel width to provide a seal between the panel and base trim.

Once the panel is in place on the base and has been plumbed, attach the panel to the base structural member. As specified in the construction drawings, install the proper number of self-drilling or self-tapping fasteners through the face of the panel and into the base member.

INTERMEDIATE SUPPORTS

The wall panel will be attached to the intermediate structural supports with through-panel fasteners. As specified in the construction drawings, install the proper number of self-drilling or self-tapping fasteners through the face of the panel and into the intermediate member.

CAUTION

Do not overtighten fasteners to a point that damages or deforms the panel.

EAVE/RAKE

The wall panel will be attached to the structural supports at the eave and rake with through-panel fasteners. As specified in the construction drawings, install the proper number of self-drilling or self-tapping fasteners through the face of the panel and into the structural supports at the eave and rake.

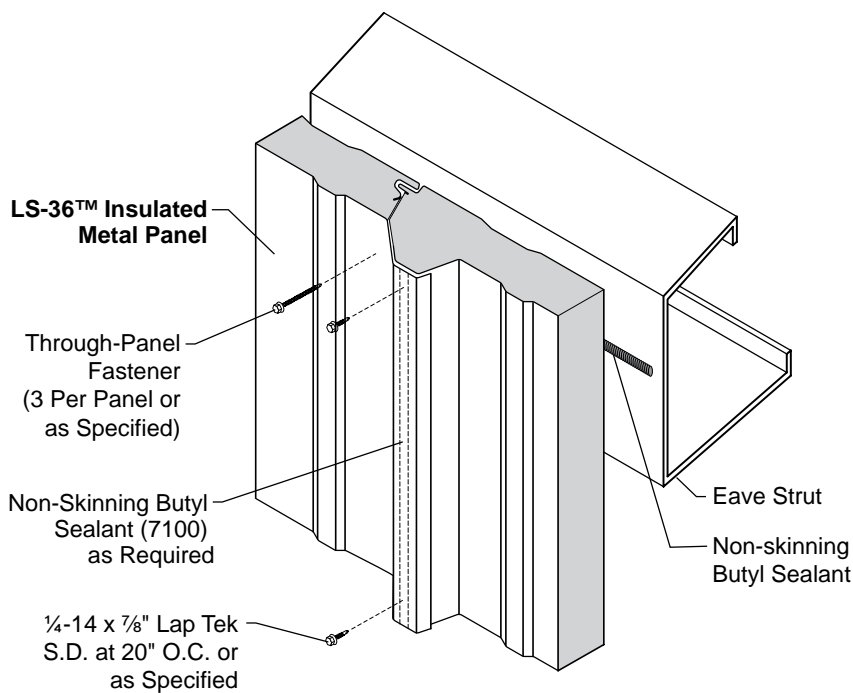

Panel Attachment at Eave/Rake

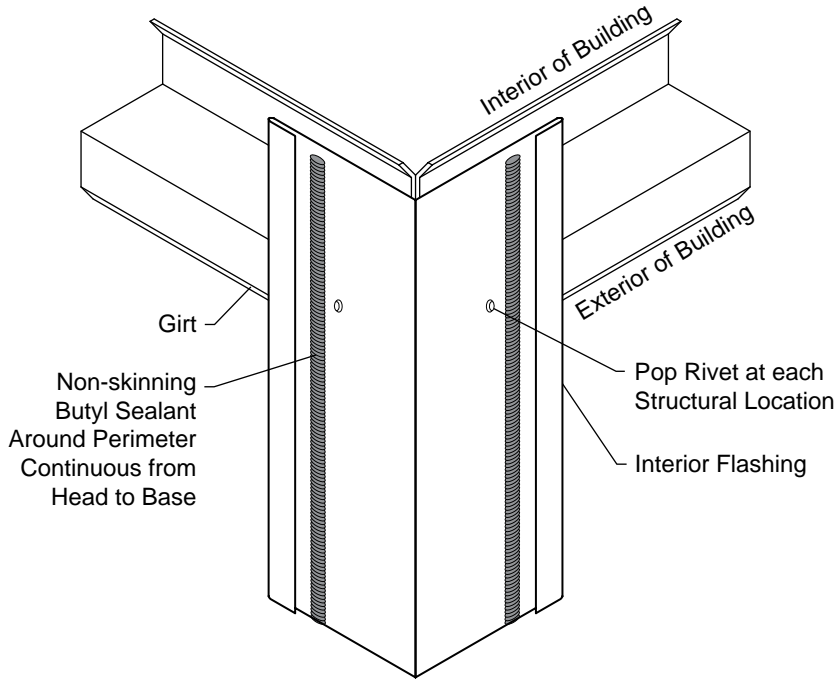

**Corner Framing and Sealant
At Interior Corner Trim**

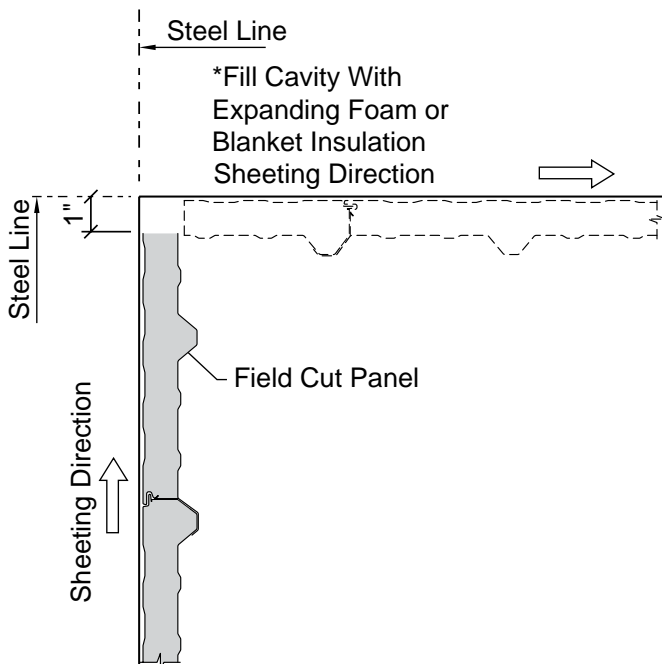

Sheeting Into Inside Corner

*Foam or Blanket Insulation is not by Metl-Span

CORNERS

The wall panels at both outside and inside corners will typically be field cut to provide a visually symmetrical wall as outlined on the "Wall Layout" **page 35**. Before installing a corner panel, make sure the interior corner flashing has been installed and the perimeter sealant has been applied to the trim. Attach the interior corner flashing with pop rivets at each structural location.

It is best to sheet away from an inside corner on both walls. When necessary to sheet into an inside corner, the panel must be cut 1" short of the steel line (if the other panel at the inside corner has not been installed) or 1" short of the opposite panel face. Fill any cavity at the inside corner with expanding foam or blanket insulation.

**CORNERS
(continued)**

The cut edge of the panel can be face fastened at the base, intermediate and eave/rake structural supports with either self-drilling or self-tapping fasteners. Apply 1" x 1/8" tape sealer to the back side of the outside corner at each hem. The corner trim may be installed with lap teks or pop rivets at 8" on center.

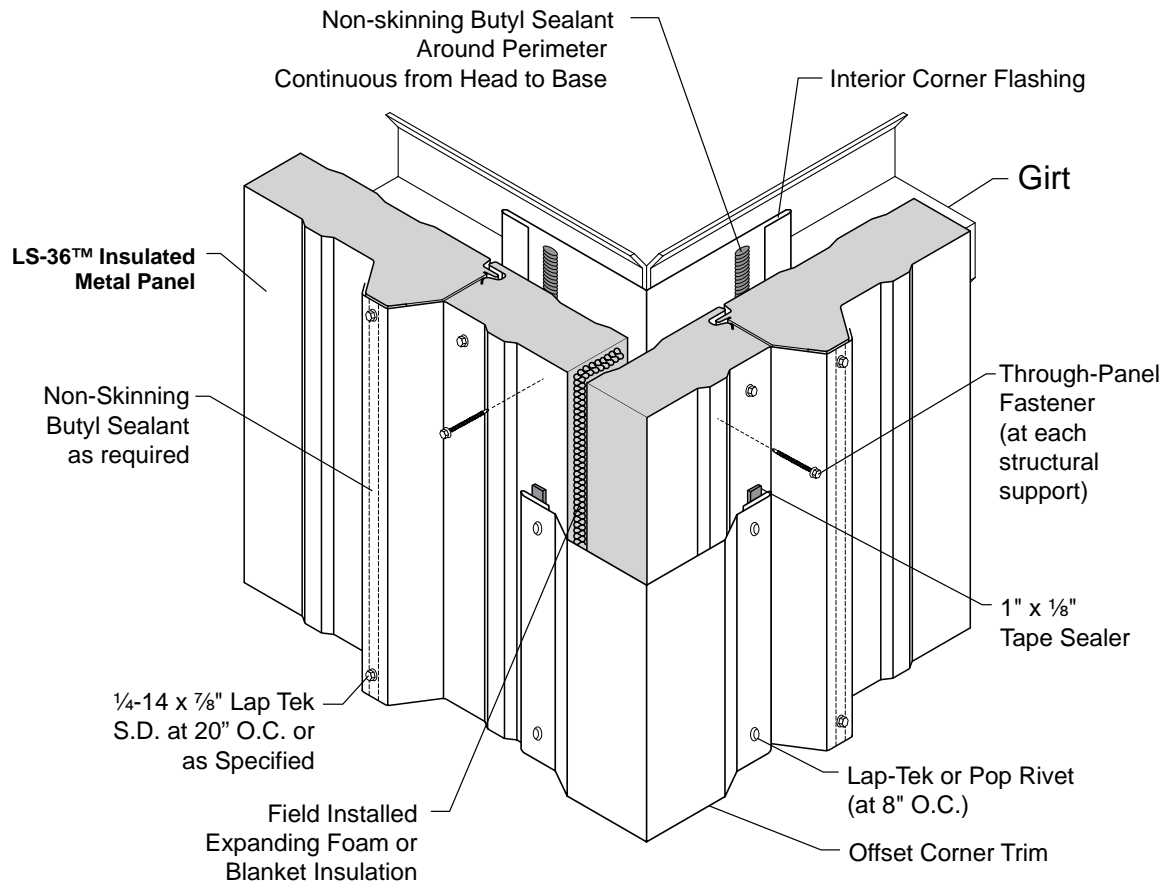

**Corner Panel Attachment
(Offset Corner Trim)**

NOTE

Install expanding foam or blanket insulation in all voids.

WALL INSTALLATION

LS-36™ INSULATED METAL ROOF & WALL PANEL

FRAMED OPENINGS

All openings, including walk doors, will require a structural framed opening. Before attaching wall panels at framed openings, make sure that the perimeter sealants have been installed.

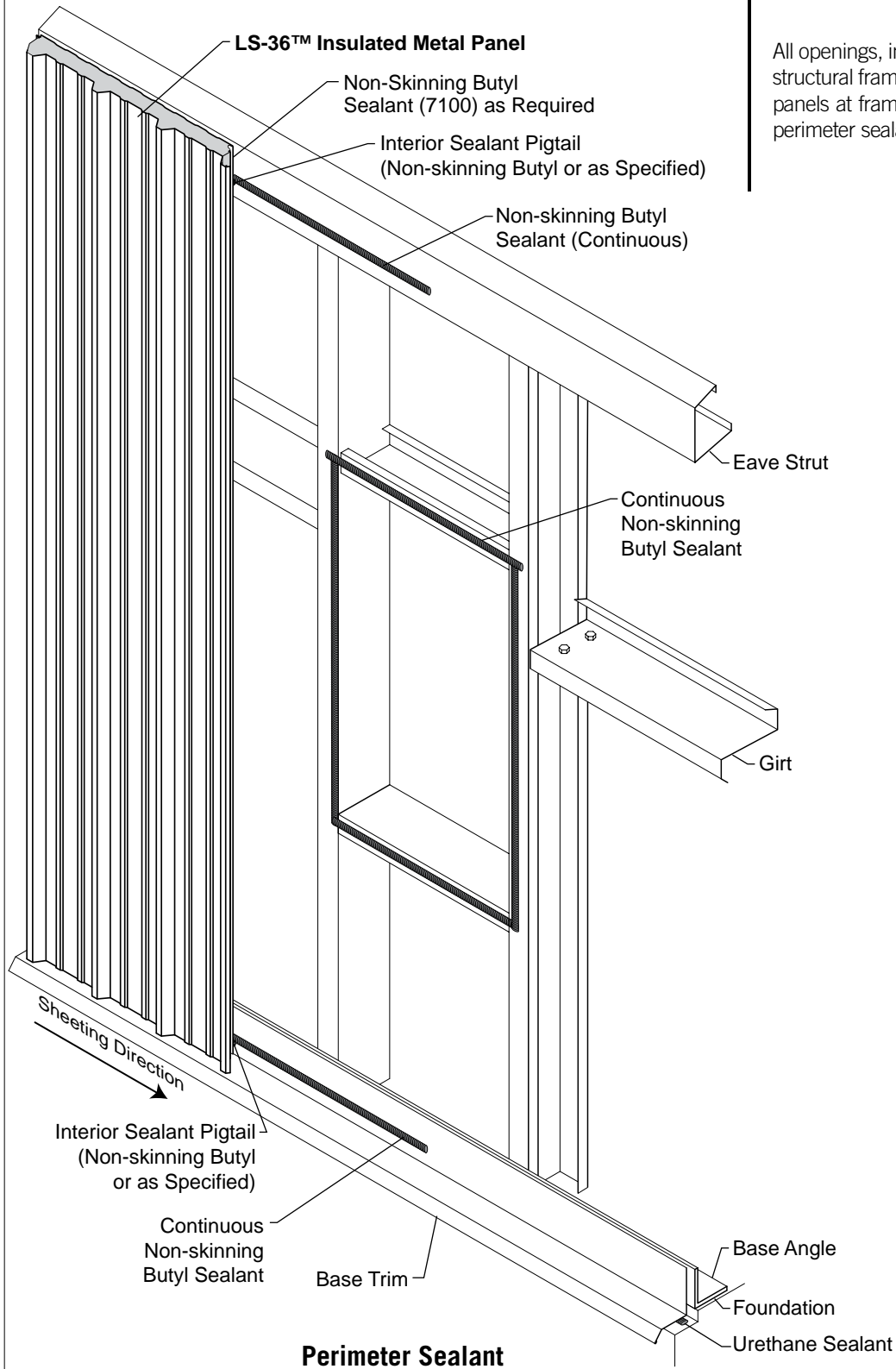

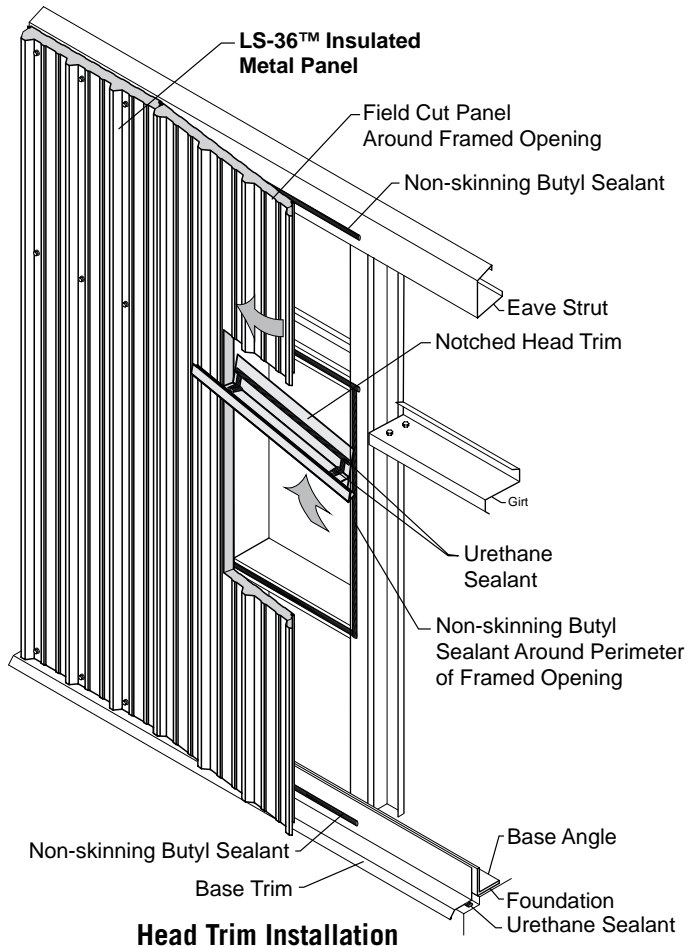
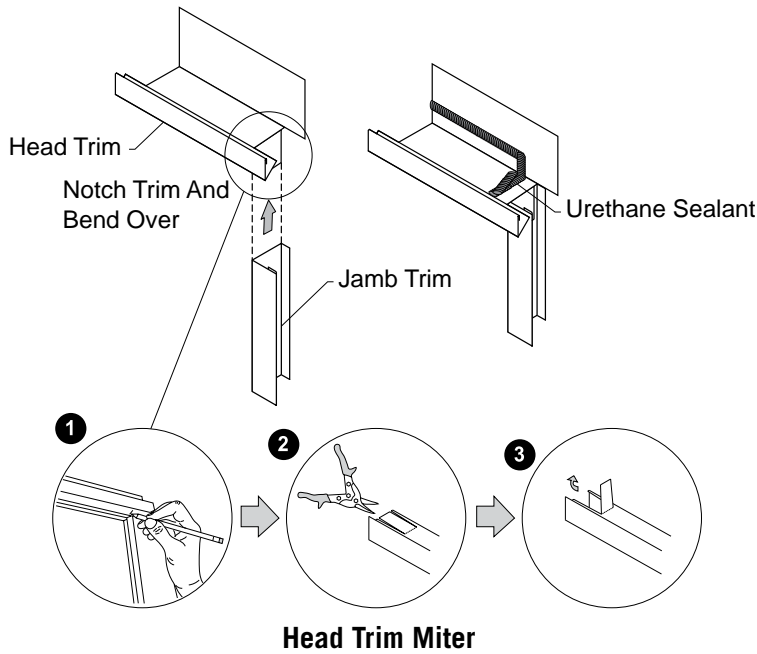

FRAMED OPENINGS (continued)

Cut the head trim to length to fit the framed opening width plus the width of the jamb trim on each side of the opening. Notch and bend tabs at each end of the head trim to allow the panels at each end of the framed opening to slide into it.

Cut the first panel to fit the framed opening and slide into place. Apply urethane sealant to the front side of the vertical leg and ends of the head trim. Use a large bead of urethane at the ends of the head trim to prevent water from getting behind the panel and to direct it into the gutter of the head trim. Slightly pull panel out, rotate and slide head trim into place.

Push wall panel with head trim back into place and secure opposite end of head trim with pancake head fastener.

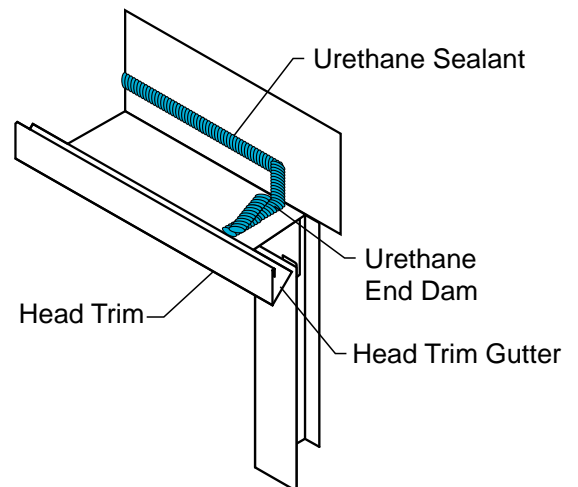

WALL INSTALLATION

LS-36™ INSULATED METAL ROOF & WALL PANEL

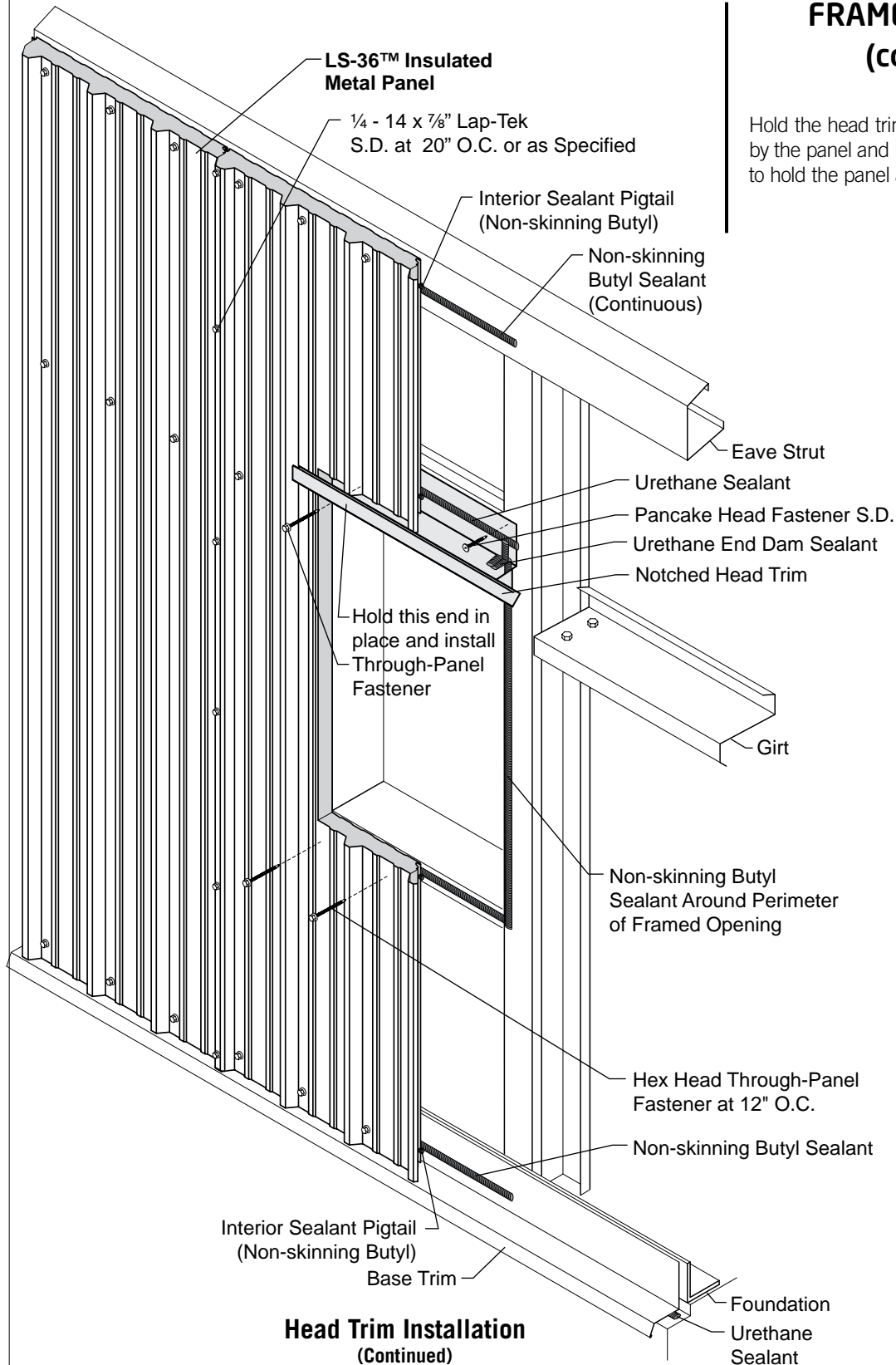

FRAMED OPENINGS (continued)

Hold the head trim in place at the end covered by the panel and install through-panel fasteners to hold the panel and head trim in place.

Head Trim Installation (Continued)

WALL INSTALLATION

LS-36™ INSULATED METAL ROOF & WALL PANEL

FRAMED OPENINGS (continued)

Install all remaining panels around the wall opening. Fasten panels at base, sill, head and eave/rake. Do not fasten panels at the jambs of the opening.

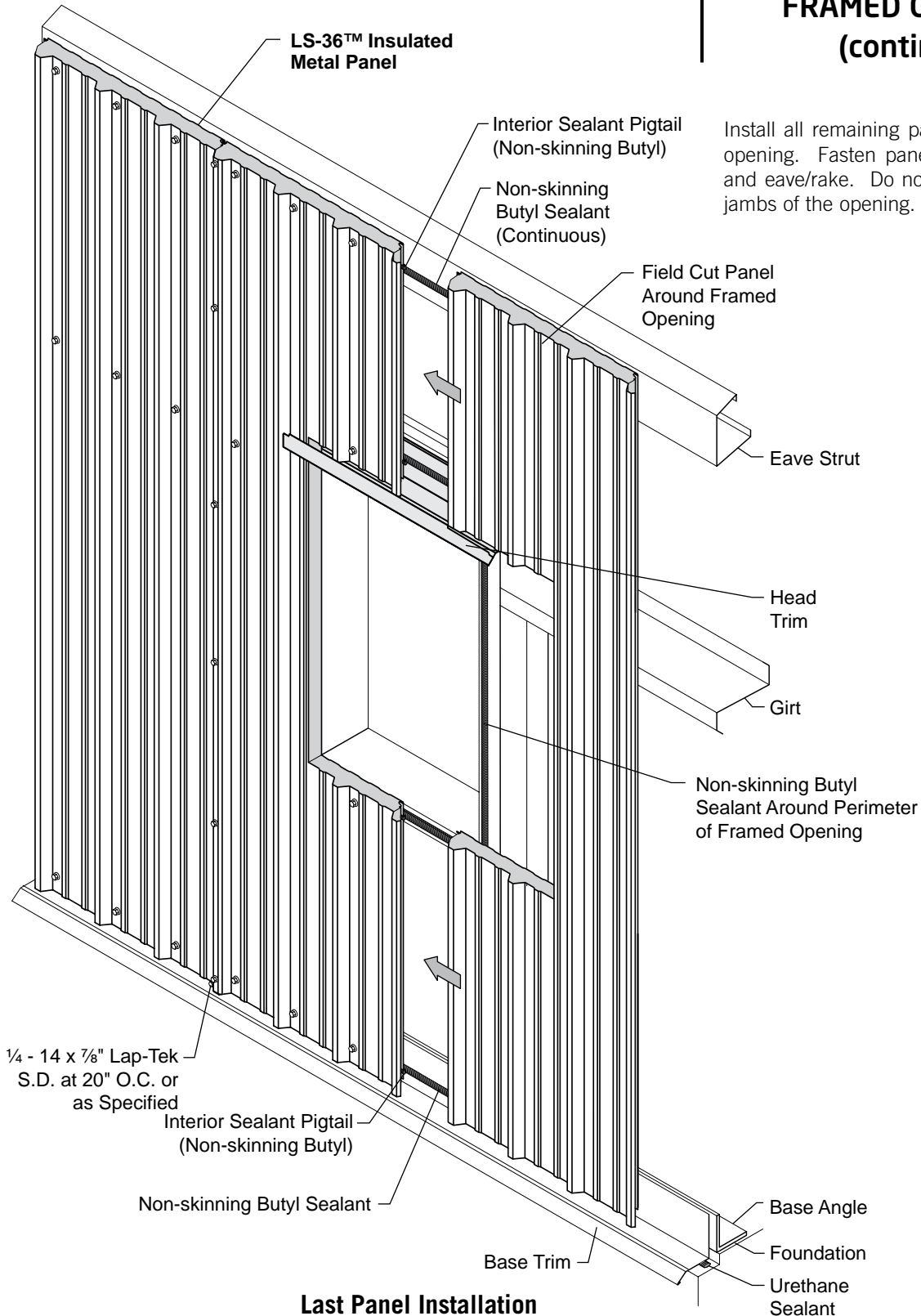

Last Panel Installation

**FRAMED OPENINGS
(continued)**

Cut sill trim length to width of opening plus 6". Bend 3 1/16" long tabs up on each end of the horizontal leg of the sill trim that are 1/8" narrower than the wall panel thickness. This should allow the horizontal leg of the sill trim to fit into the window opening. Check fit of sill trim in wall opening to ensure a tight fit-up. Mark the bottom of the sill trim on the wall to determine location of outside closures.

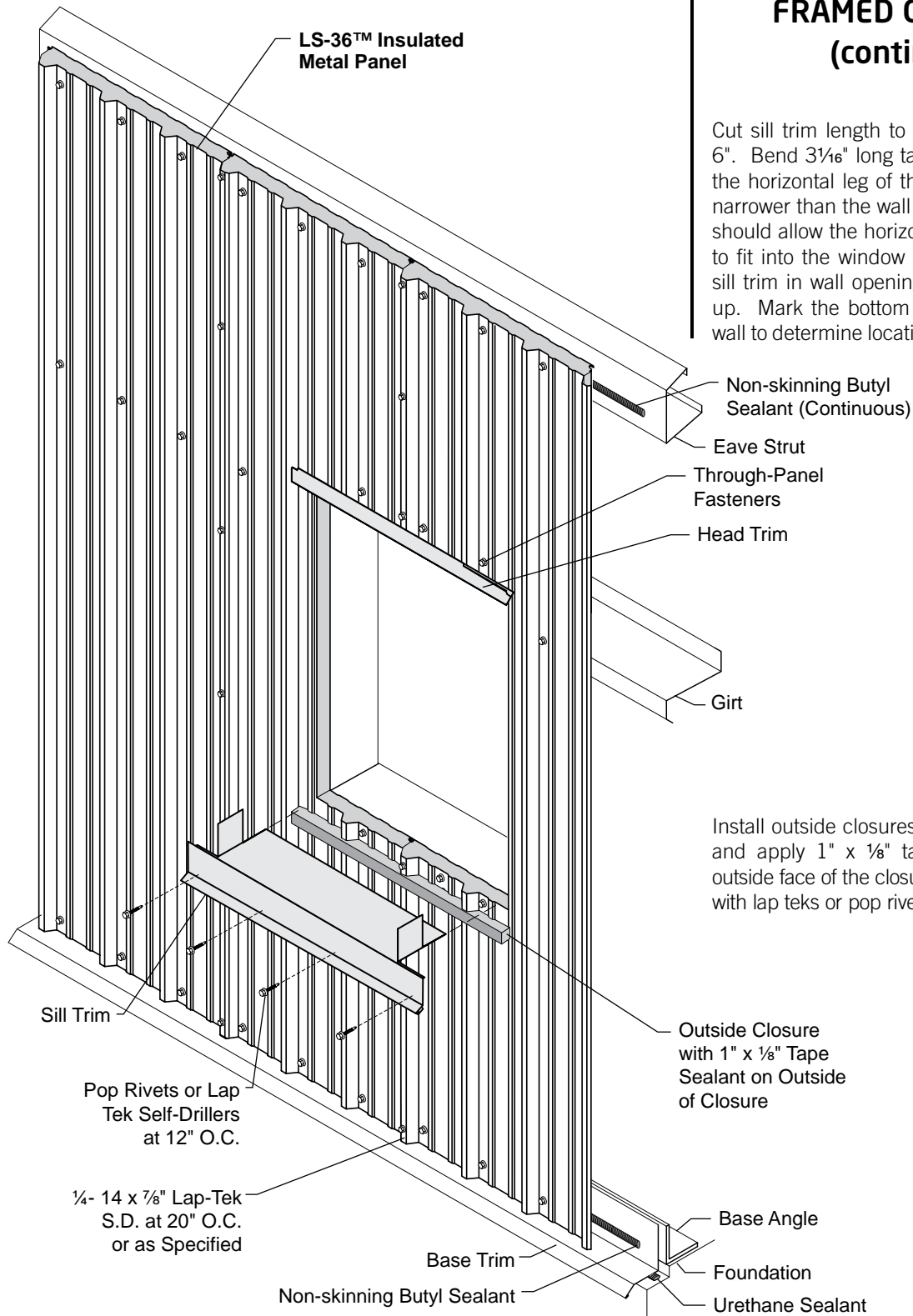

Install outside closures at sill of wall opening and apply 1" x 1/8" tape sealer across the outside face of the closures. Install the sill trim with lap teks or pop rivets at each panel rib.

Sill Trim Installation

**FRAMED OPENINGS
(continued)**

Cut jamb trim to fit between sill trim and head trim. The bottom of the jamb trim will be mitered to the sill trim.

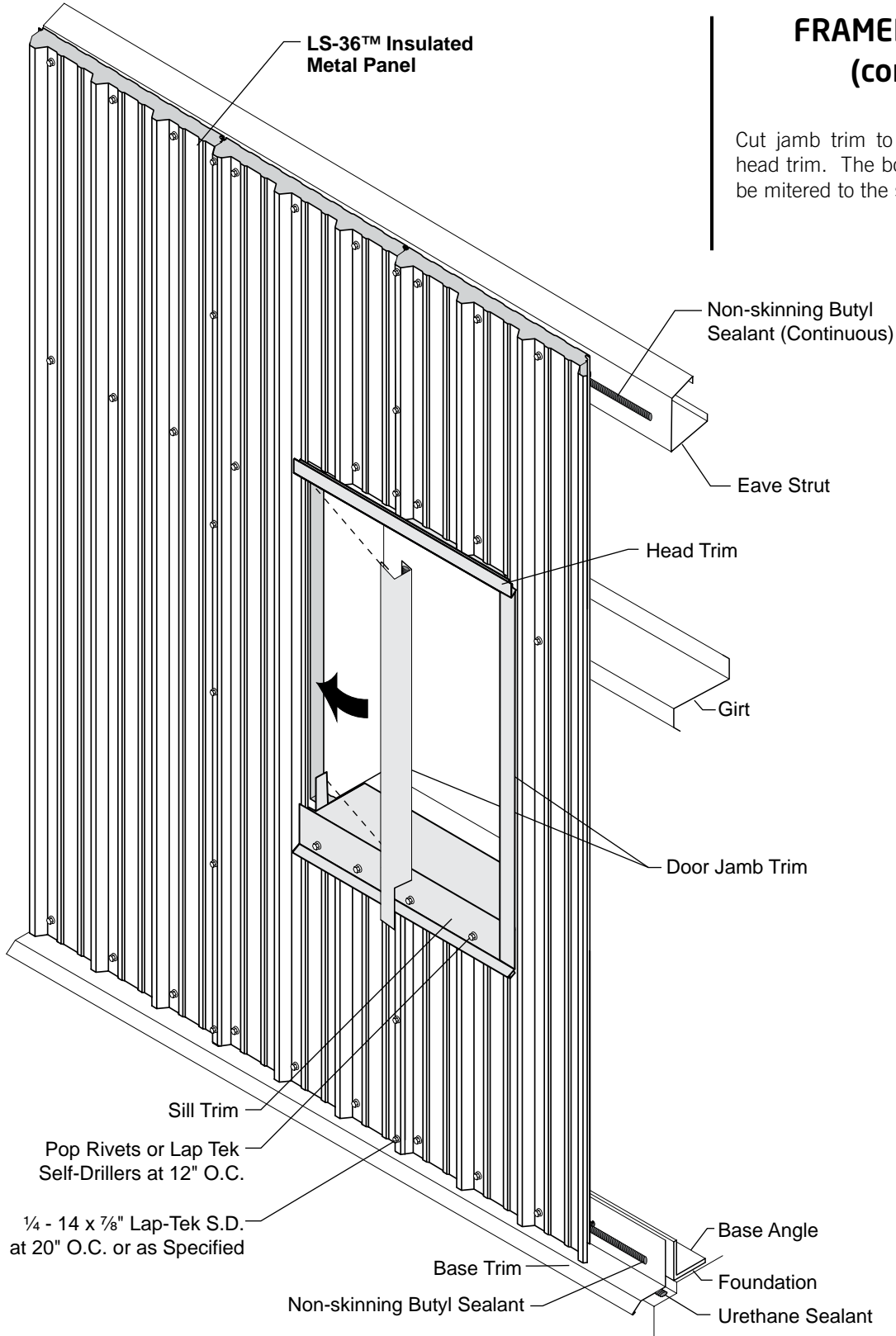

Jamb Trim Installation

WALL INSTALLATION

LS-36™ INSULATED METAL ROOF & WALL PANEL

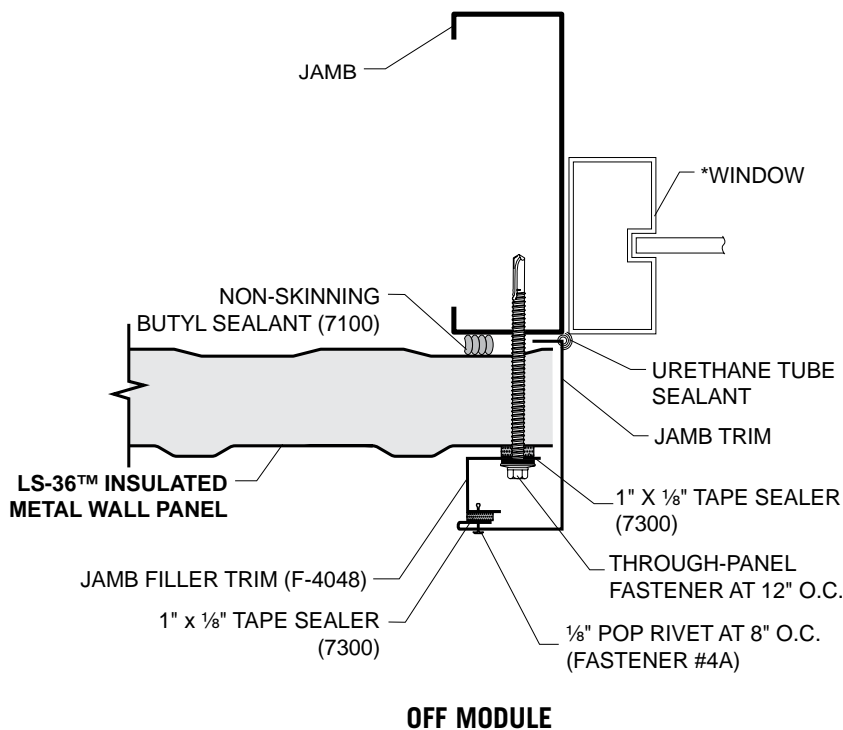
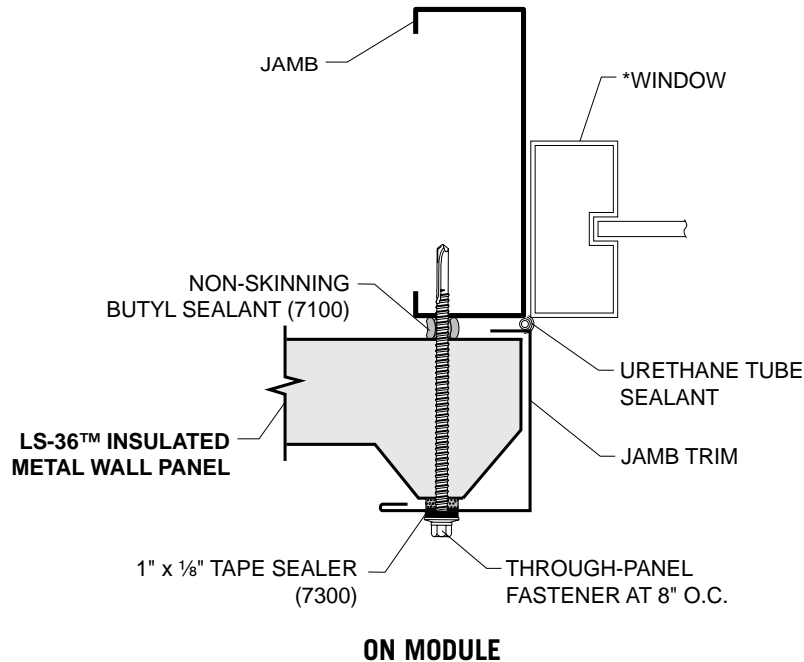

FRAMED OPENINGS (continued)

If a panel falls at edge of opening, the panel will be attached to the jamb of the window frame with through panel fasteners at 12" on center when the jamb trim is installed.

If the panel flat falls at the edge of the opening, attach Jamb Filler Trim and wall panel to the jamb of the window frame with through-panel fasteners at 12" on center. Install 1" x 1/8" tape sealer to the back of the Jamb Filler Trim before installation.

Install 1" x 1/8" Tape Sealer to front of Jamb Filler Trim and attach Jamb Trim with Pop Rivets or Lap Tek's at 8" on center.

*WINDOW NOT BY METL-SPAN

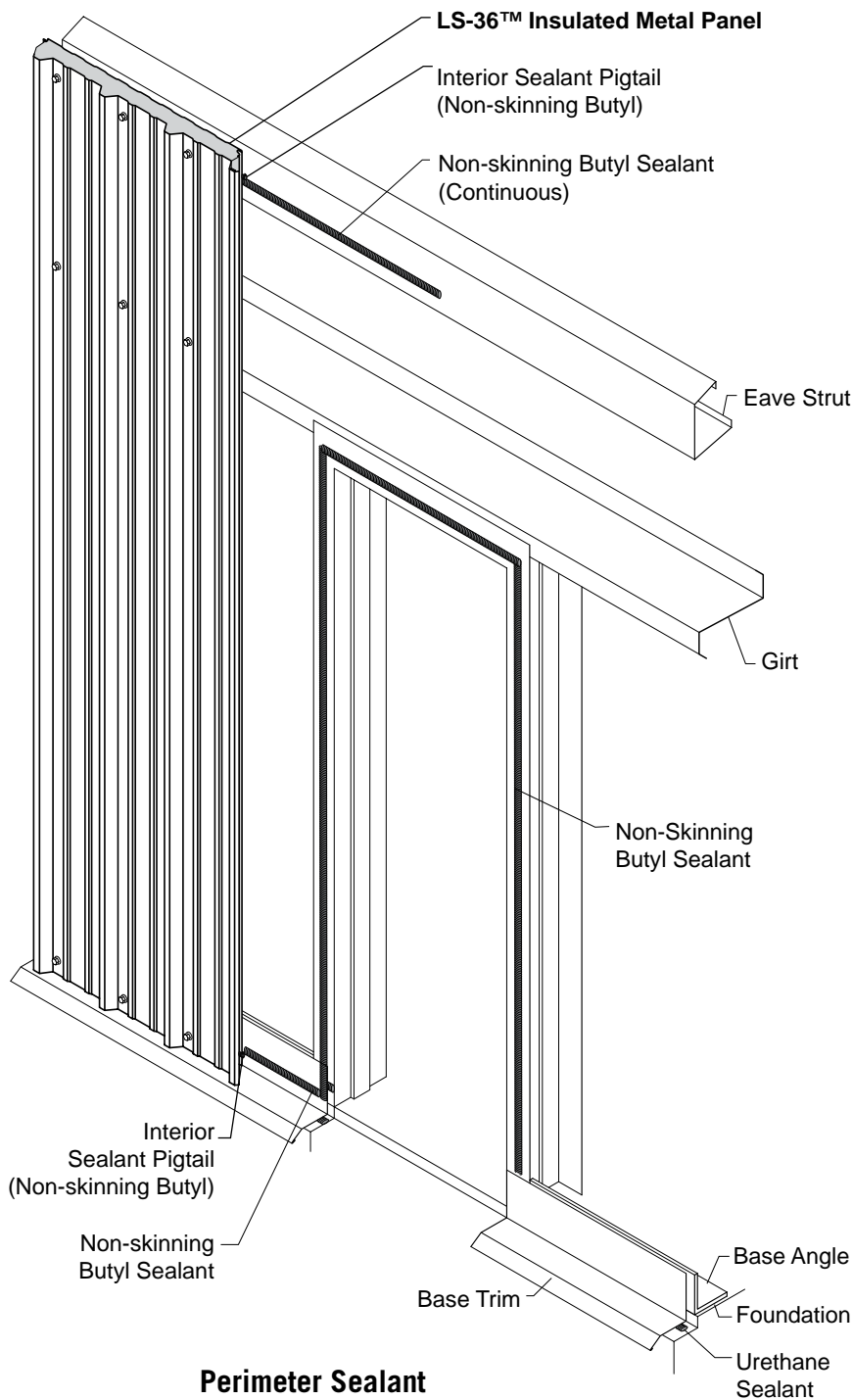

DOOR OPENINGS

At door openings, the jamb trim will be installed after the panels have been fastened to the substructure. The head trim will be installed as the first panel at the door opening is installed.

Apply a 3/8" bead of non-skinning butyl sealant to the exterior of the door frame at the head and jambs. Sealant bead should be approximately 1" from the edge of the door frame.

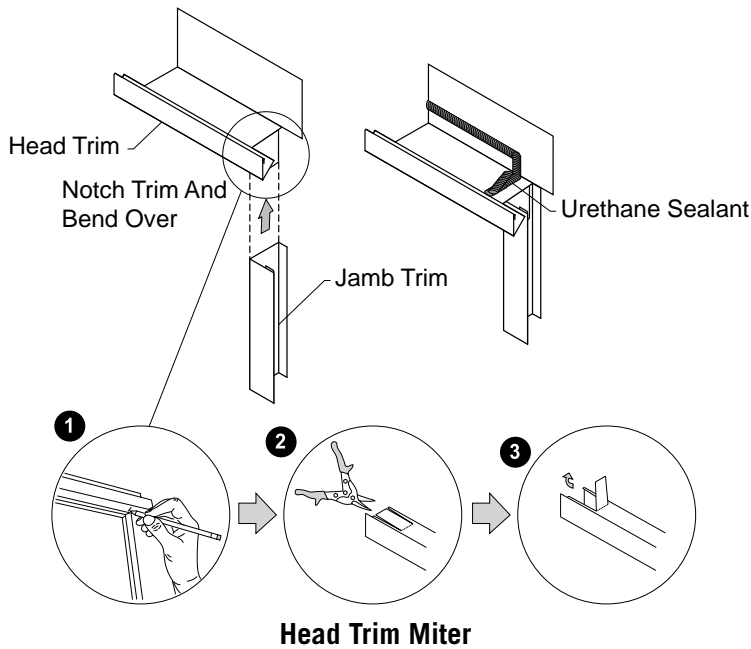

DOOR OPENINGS (continued)

Cut the head trim to length to fit the framed opening width plus the width of the jamb trim on each side of the opening. Notch and bend tabs at each end of the head trim to allow the panels at each end of the framed opening to slide into it.

Apply urethane sealant to the front side of the vertical leg and ends of the head trim. Use a large bead of urethane at the ends of the head trim to prevent water from getting behind the panel and to direct it into the gutter of the head trim.

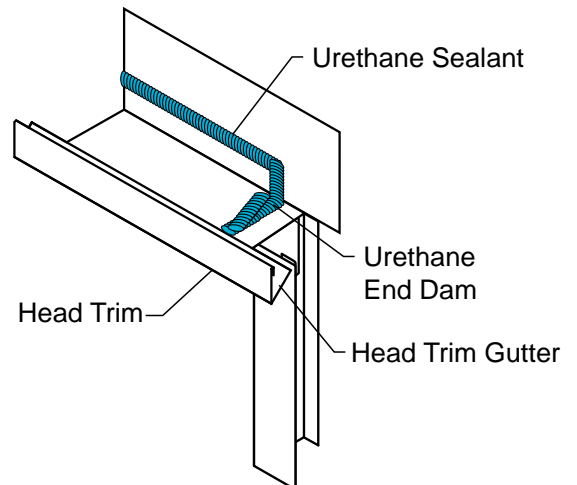
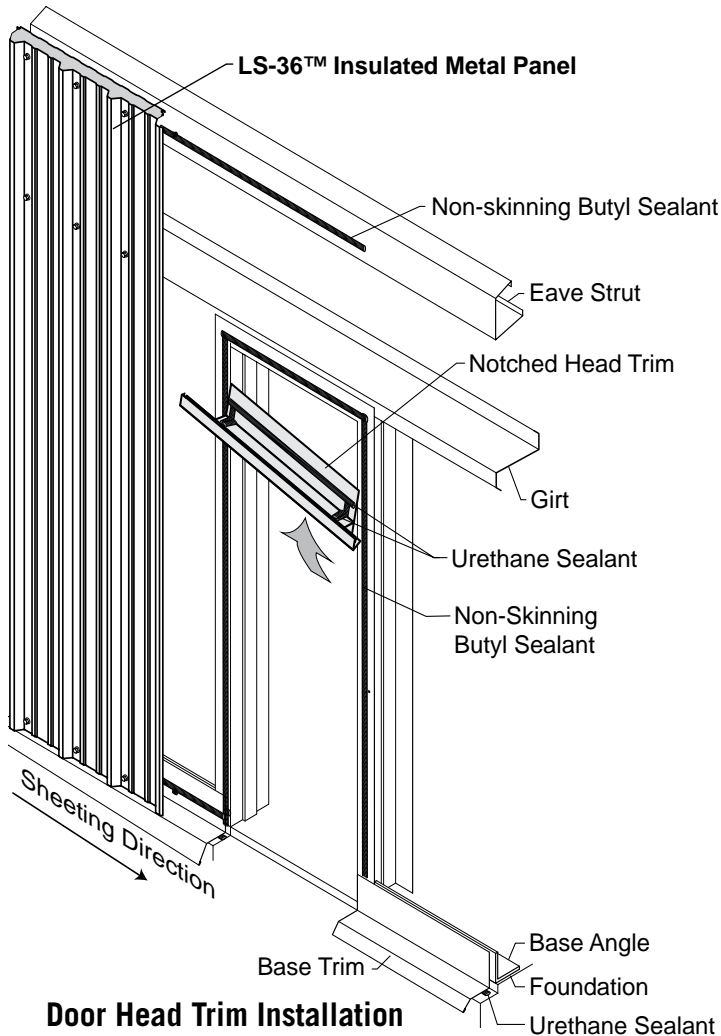

**DOOR OPENINGS
(continued)**

Cut the first panel to fit the door opening and slide into place. Slightly pull the wall panel out, away from the door frame and slide the head trim into place.

Push the wall panel and the head trim into place and secure the opposite end of the head trim with pancake head fasteners.

Fasten panel to substructure as normal.

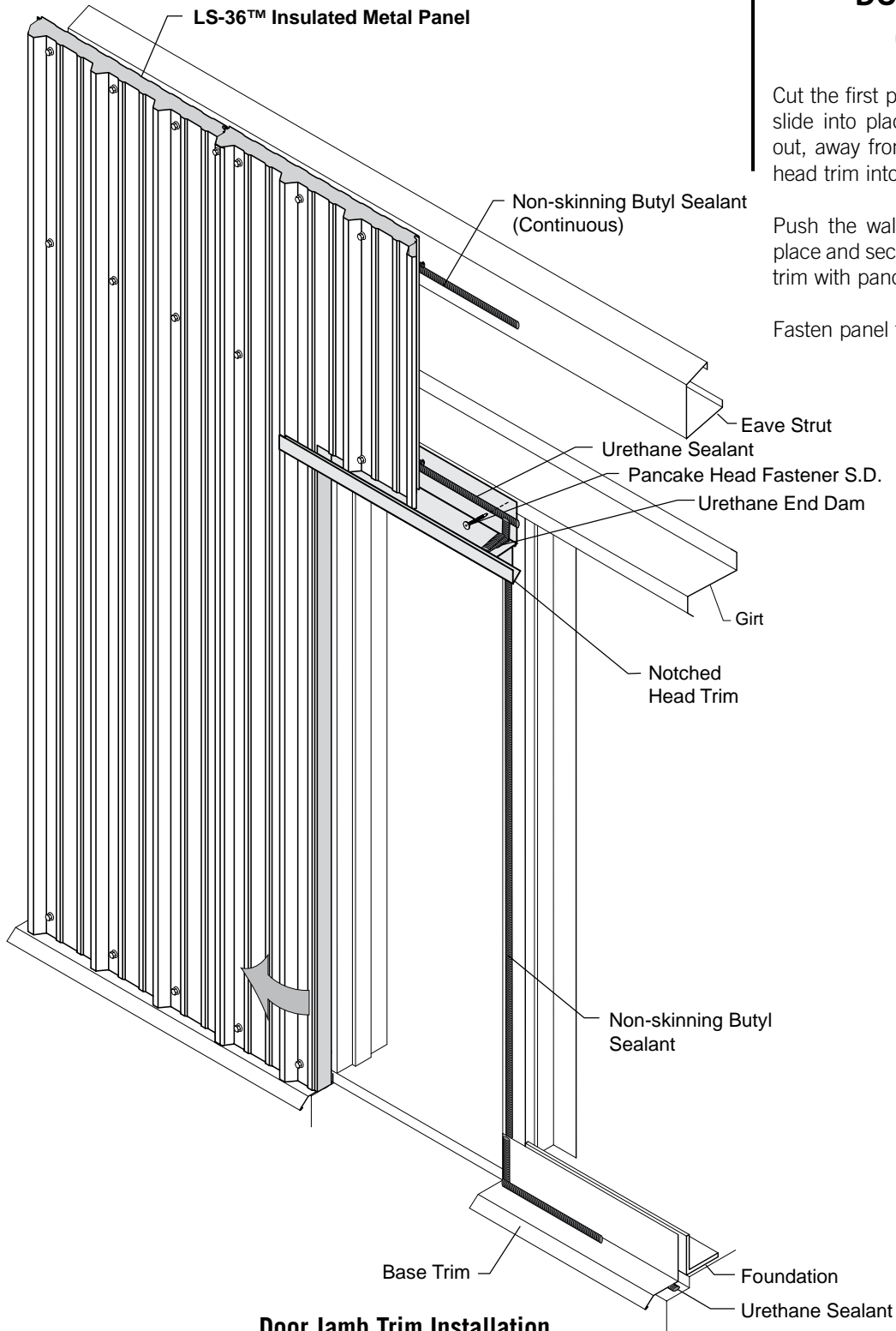

Door Jamb Trim Installation

**DOOR OPENINGS
(continued)**

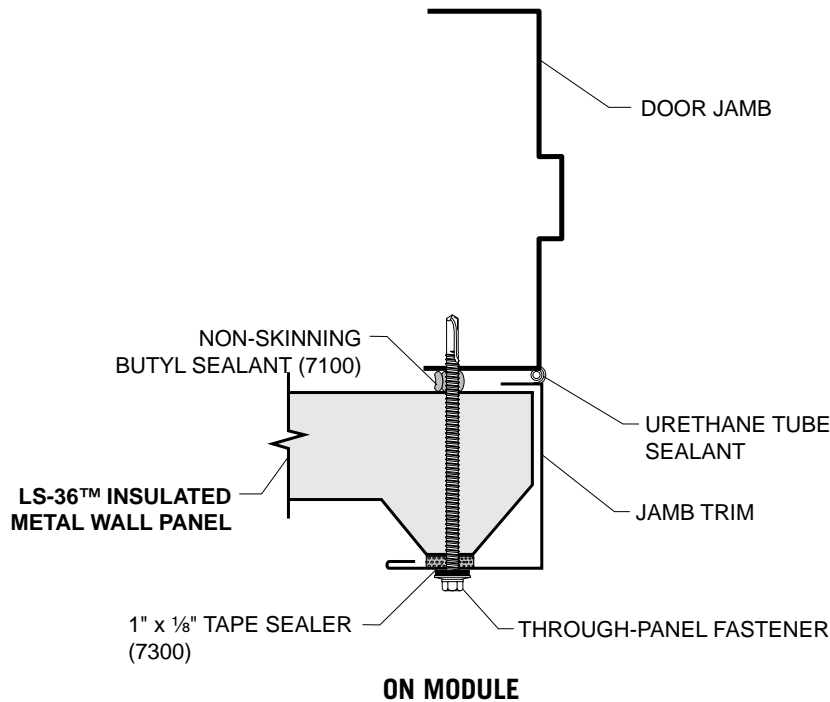

If panel rib falls at edge of door opening, the panel will be attached to the jamb of the door frame with through panel fasteners at 12" on center when the jamb trim is installed.

If the panel flat falls at the edge of the door opening, attach Jamb Filler Trim and wall panel to the jamb of the door frame with through panel fasteners at 12" on center. Install 1" x 1/8" tape sealer to the back of the Jamb Filler Trim before installation.

Install 1" x 1/8" Tape Sealer to front of Jamb Filler Trim and attach Jamb Trim with Pop Rivets or Lap Tek's at 8" on center.

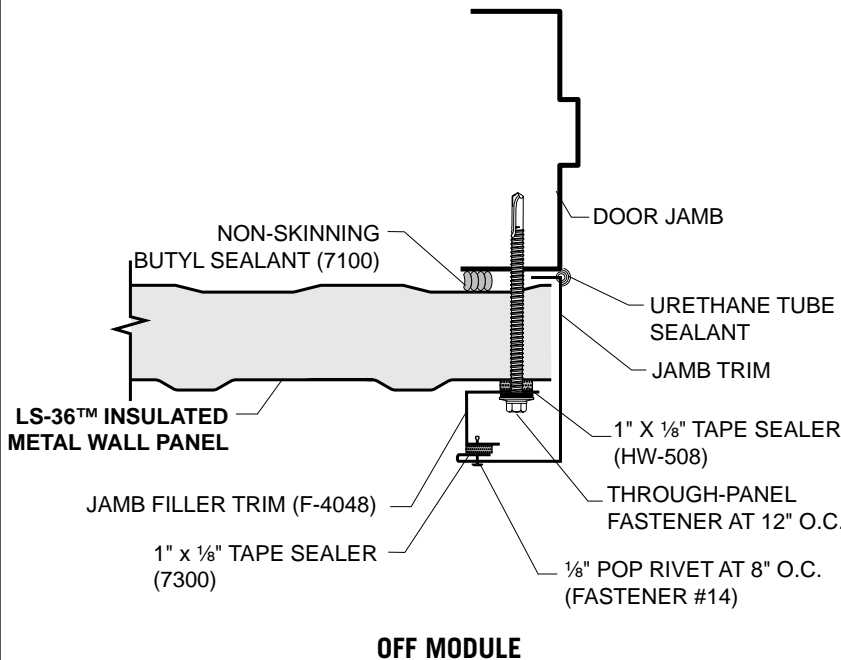

WALL INSTALLATION

LS-36™ INSULATED METAL ROOF & WALL PANEL

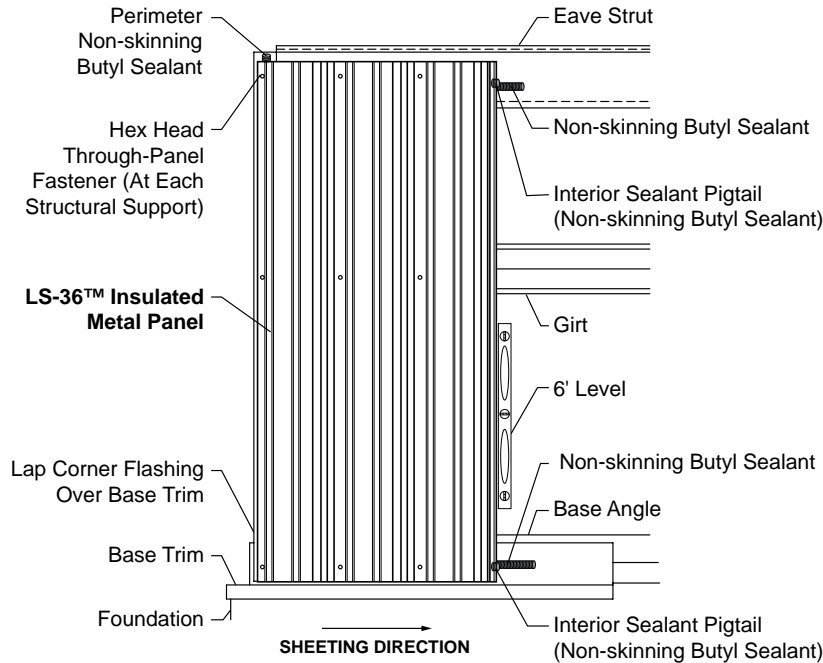

Setting First Panel

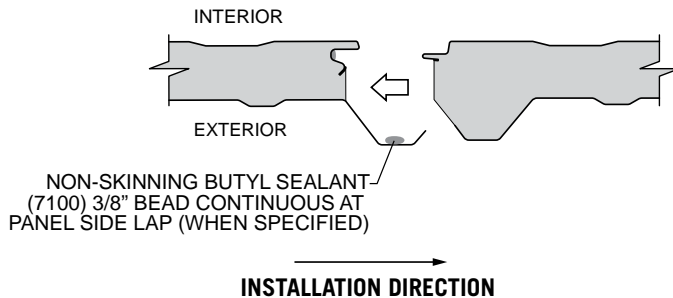

INSTALLATION DIRECTION

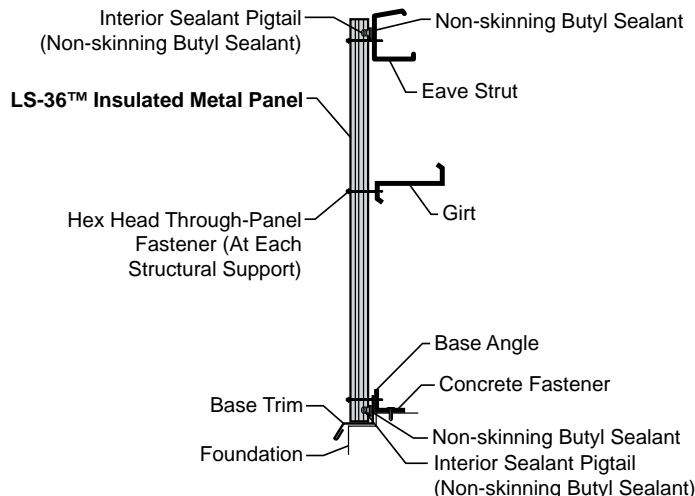

Setting First Panel (Through-Fastener Attachment)

FIRST PANEL

Before installing the first panel, make sure you have thoroughly reviewed the previous pages of this manual and are familiar with all requirements to ensure proper installation.

Set the first panel on the base trim and confirm that it is properly aligned with the steel line of the building and is plumb. **See page 29 for acceptable alignment.** Use a 6' level and set it against the uncut edge of the panel to check plumb.

The LS-36™ Insulated Metal Panels are best installed backwards from the way single skin R panels are installed. The leading panel rib of the exterior skin will lap to the outside of the panel rib of the next panel. Each successive panel will install with its' exterior panel rib fitting under the panel rib of the previous panel. This makes it easier to simultaneously engage the exterior skin side lap and the tongue and groove joinery of the interior skin.

Visually check to see that the panel touches all structural members at the base, intermediate girts and the eave/rake. Forcing the panel to conform to out-of-plane structurals will cause the panel to oil can. Attach the panel to the building structurals with thru-panel fasteners as previously outlined.

Face fasten the panel with hex head fasteners at the base, intermediate structurals and eave/rake.

INTERMEDIATE PANELS

If panels were not ordered with factory installed vapor cavity sealant, field apply sealant when shown on the construction drawings. **Apply pigtail sealant to previous panel as outlined on Panel Sealant Requirements page 37.** If required, also install Non-skinning Butyl Sealant to panel side lap.

Position the panel on the base assembly so that its edge will just clear the side lap of the previously installed panel and raise it into place. To prevent sealant displacement during panel engagement, a 1" gap must be maintained when installing intermediate panels.

Push the panel toward the previously installed panel to engage the tongue-and-groove side lap. Make sure the panel joint is fully engaged and uniform along the entire length of the panel. If difficulty in fully engaging the panel is encountered, there may be damage to the side lap of one of the panels. If the panel is disengaged for any reason, make sure that any dislodged mastic in the panel side lap or at the base and/or head is reapplied.

Once the panel is fully engaged to the previously installed panel, check for plumb and attach the panel to the building structurals with through-panel fasteners as previously outlined.

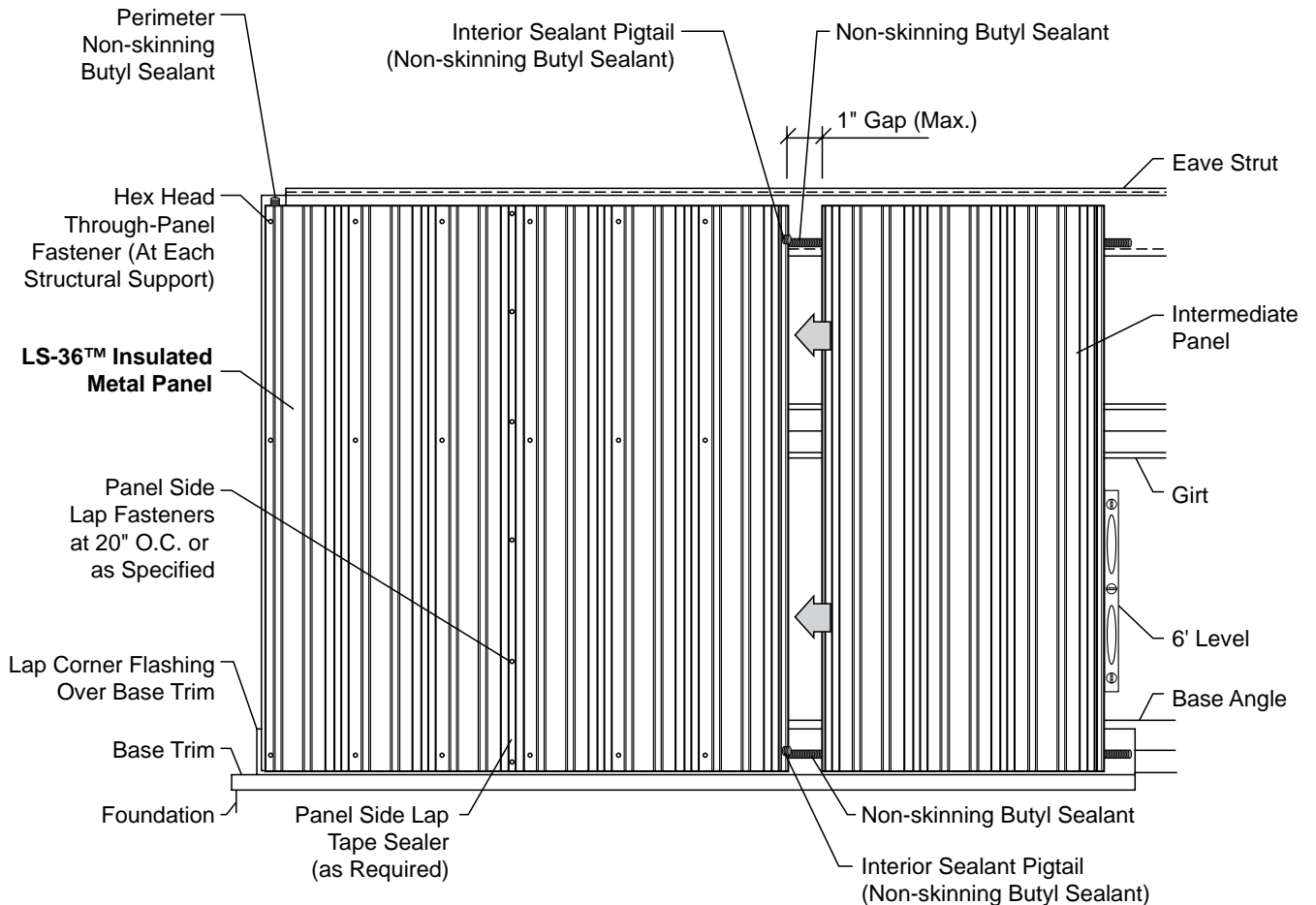

Setting Intermediate Panels

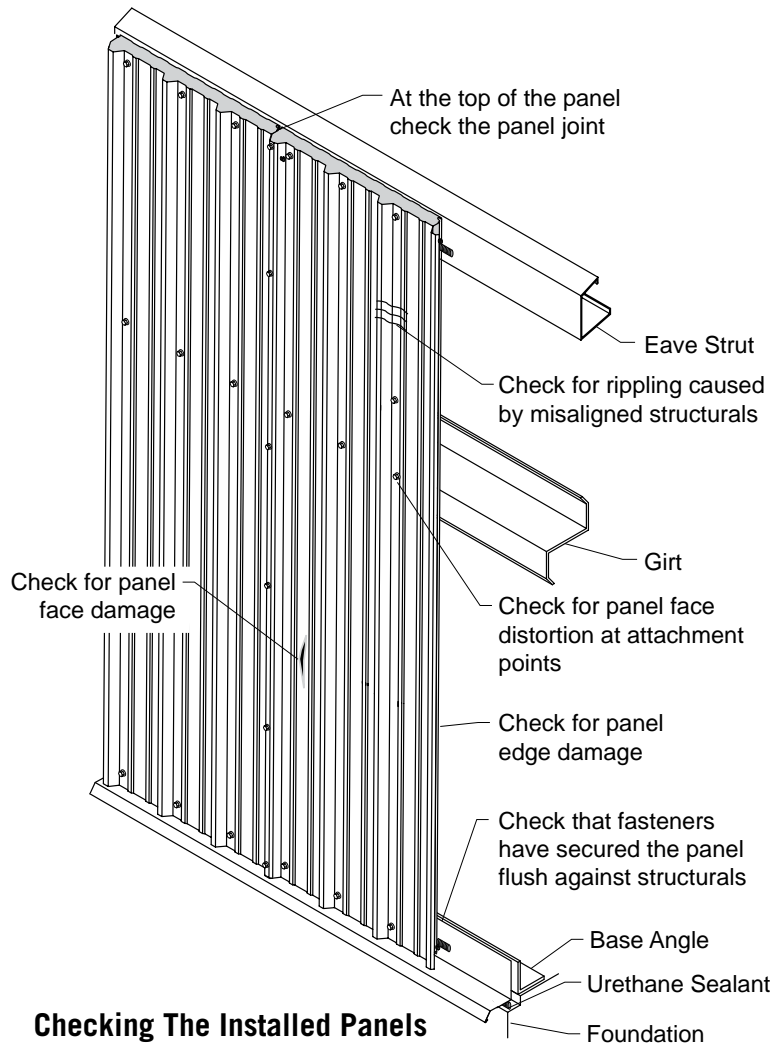

Checking The Installed Panels

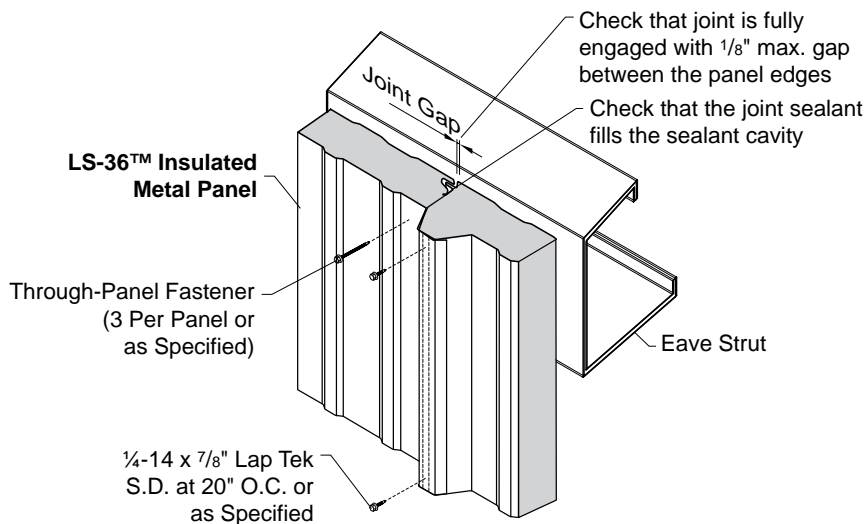

Checking The Panel Joint

QUALITY CONTROL

It is critical to check each panel before installation to ensure that it is not damaged. After each panel has been installed, check for the following:

Panels

- Check for ripples in the panels caused by misaligned structural framing members or overtightened fasteners.
- Check for dents and scratches.
- Check the full length of the exposed tongue-and-groove side lap for damage before trying to engage the next panel.

Panel Joint

- Check side laps for complete engagement.
- Check that the tongue is fully embedded in the sealant within the tongue-and-groove side lap.
- Check that the full length of the side lap joint has a uniform gap width up to $\frac{1}{8}$ ".

The above inspections are aided by having the installer attaching the top of the panels to the structure look down the length of the panels as they are installed.

FASTENER AND JOINT SEALANT APPLICATION

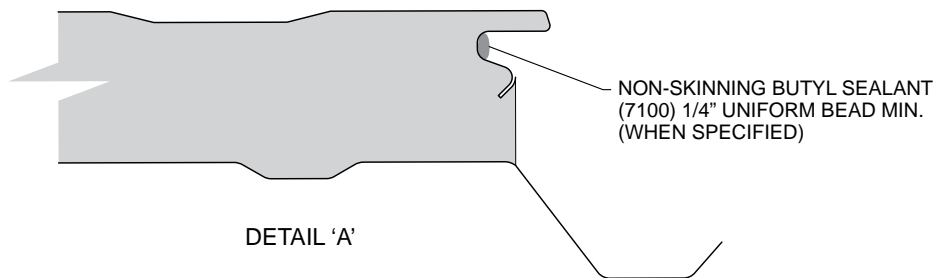
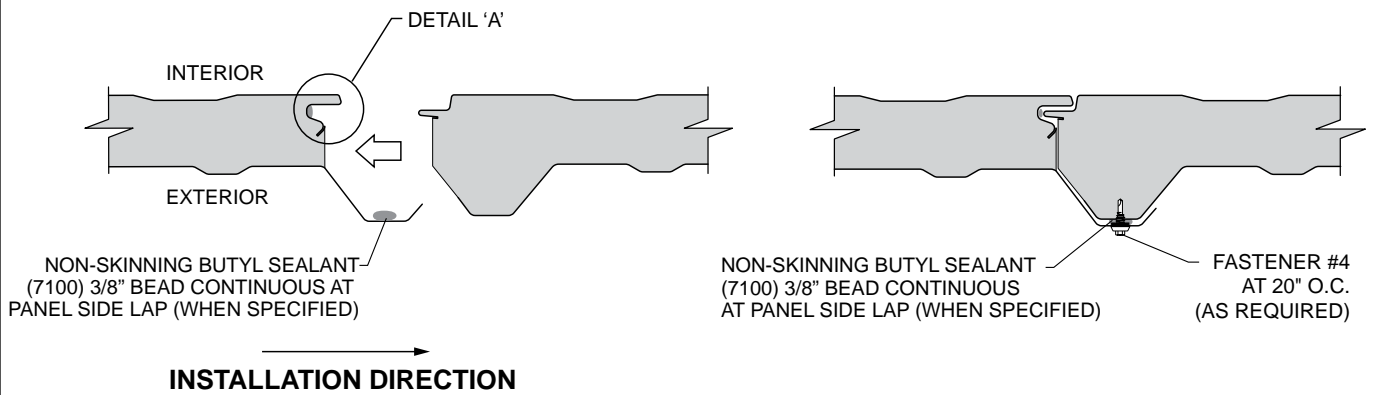
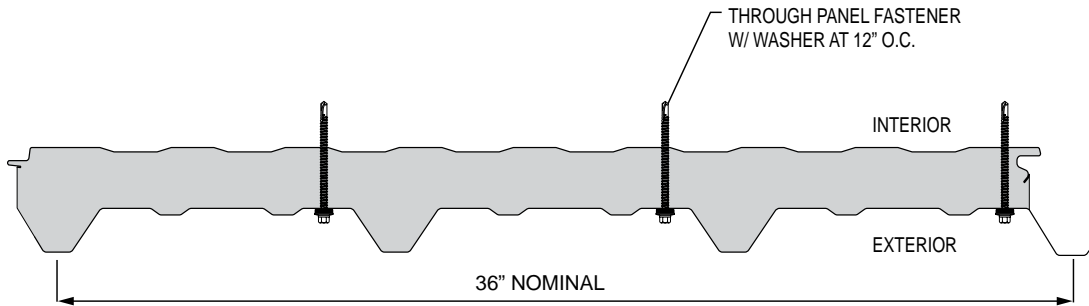

WALL BASE-With Recess

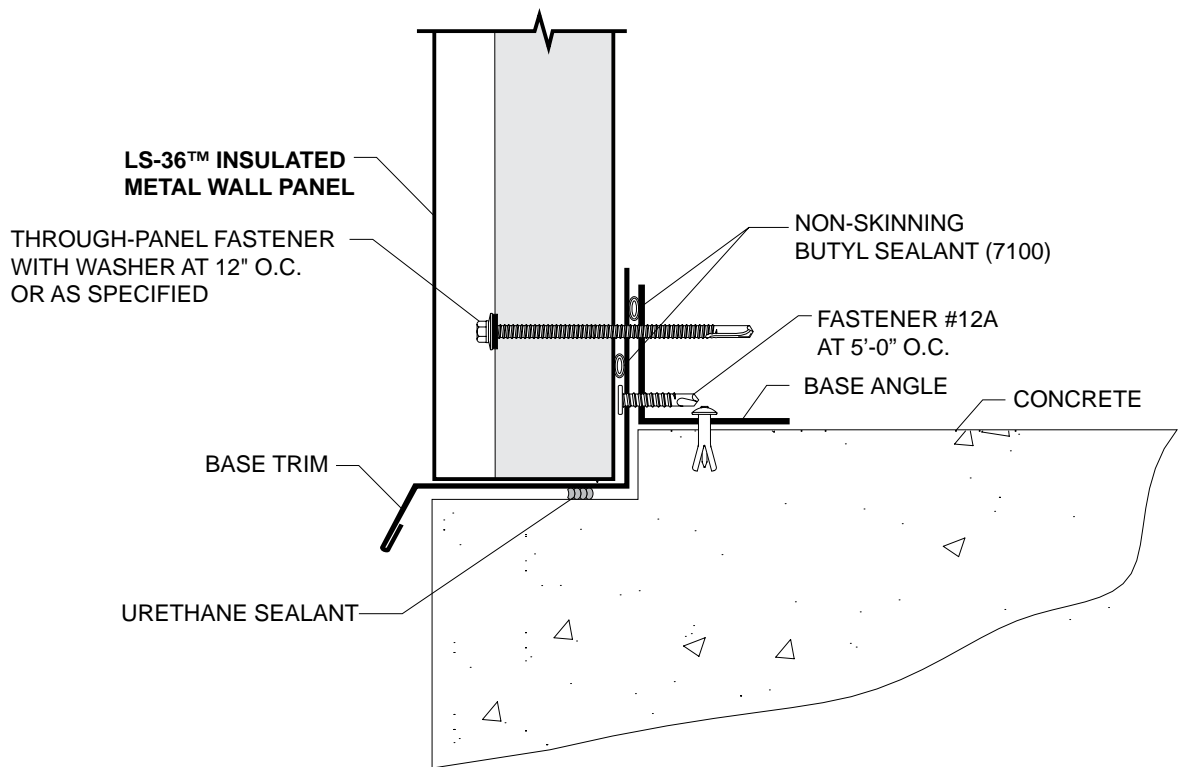

WALL BASE-Without Recess

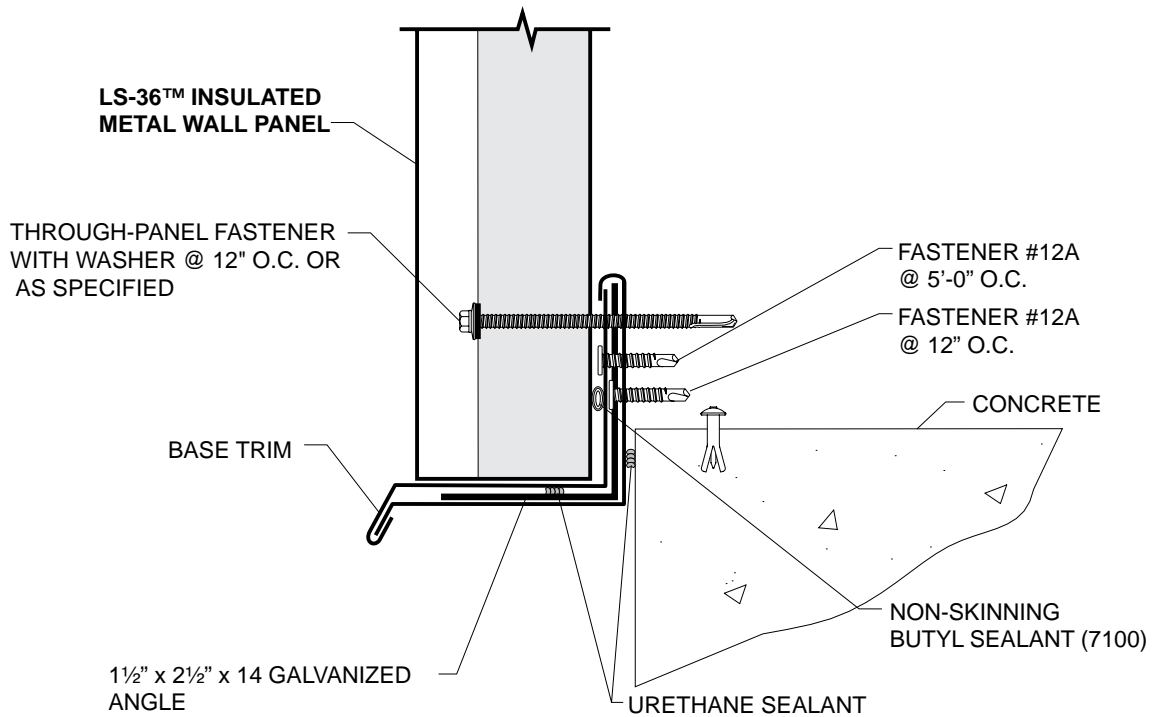

OUTSIDE CORNER

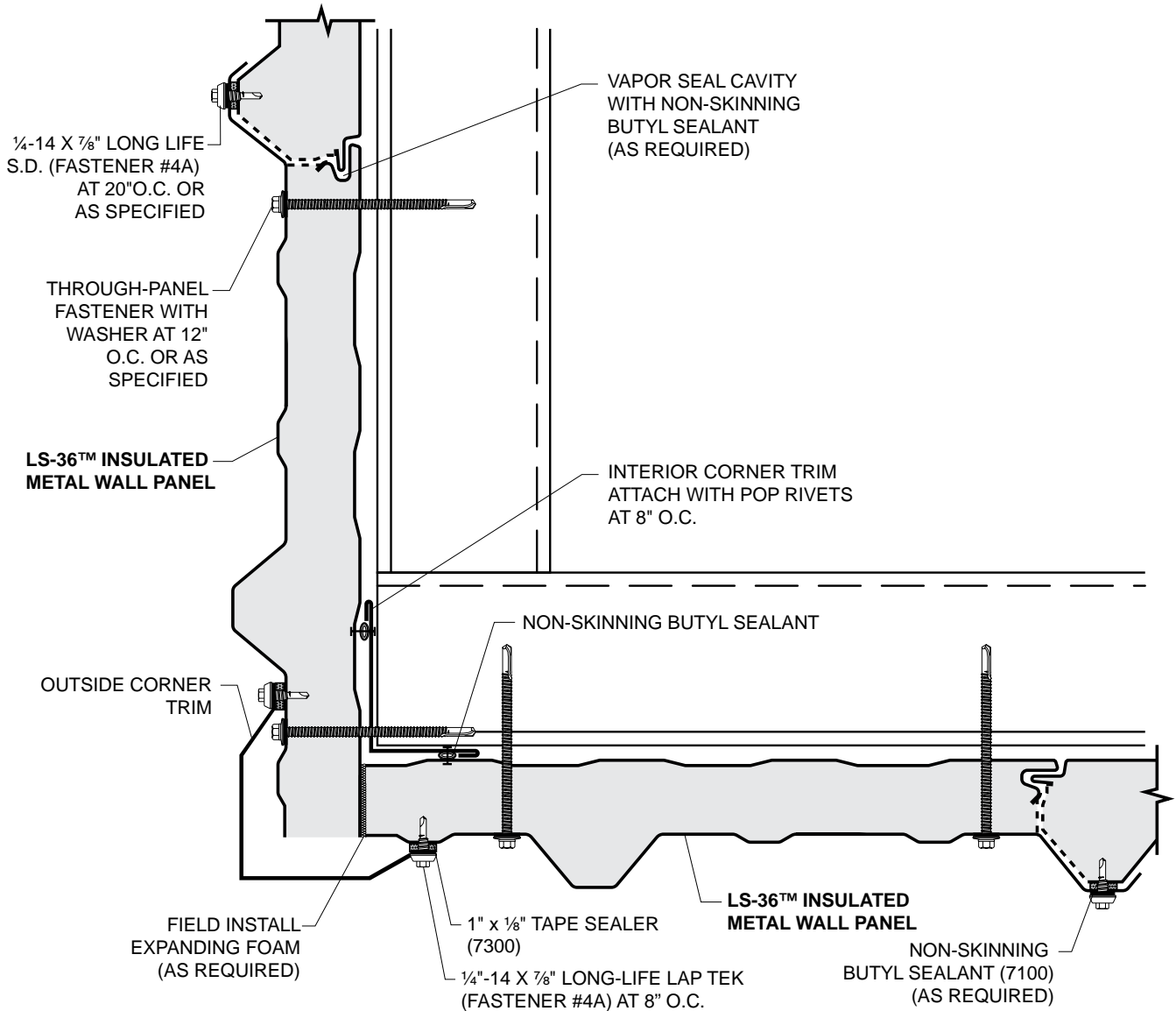

INSIDE CORNER

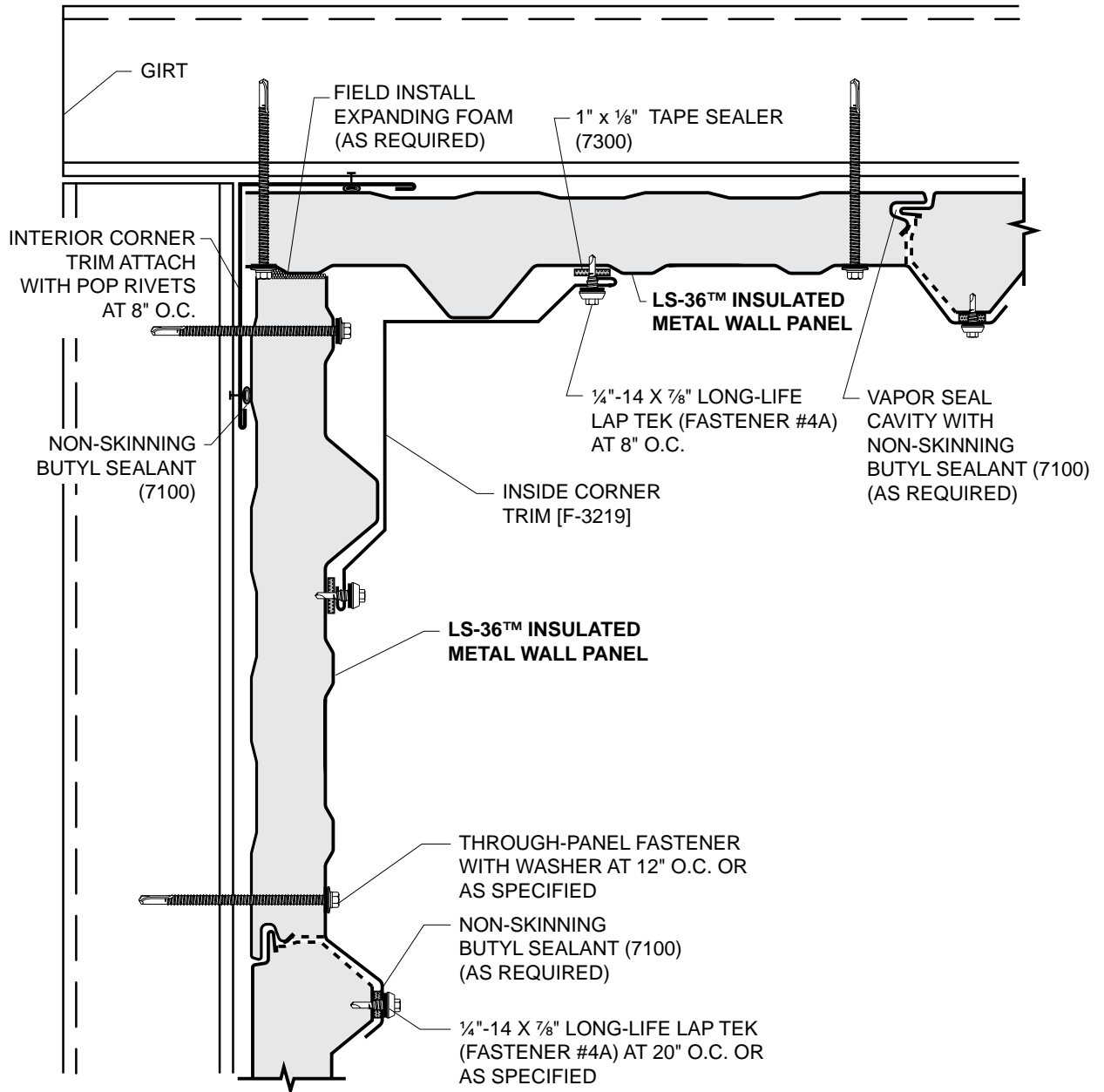

WINDOW HEAD

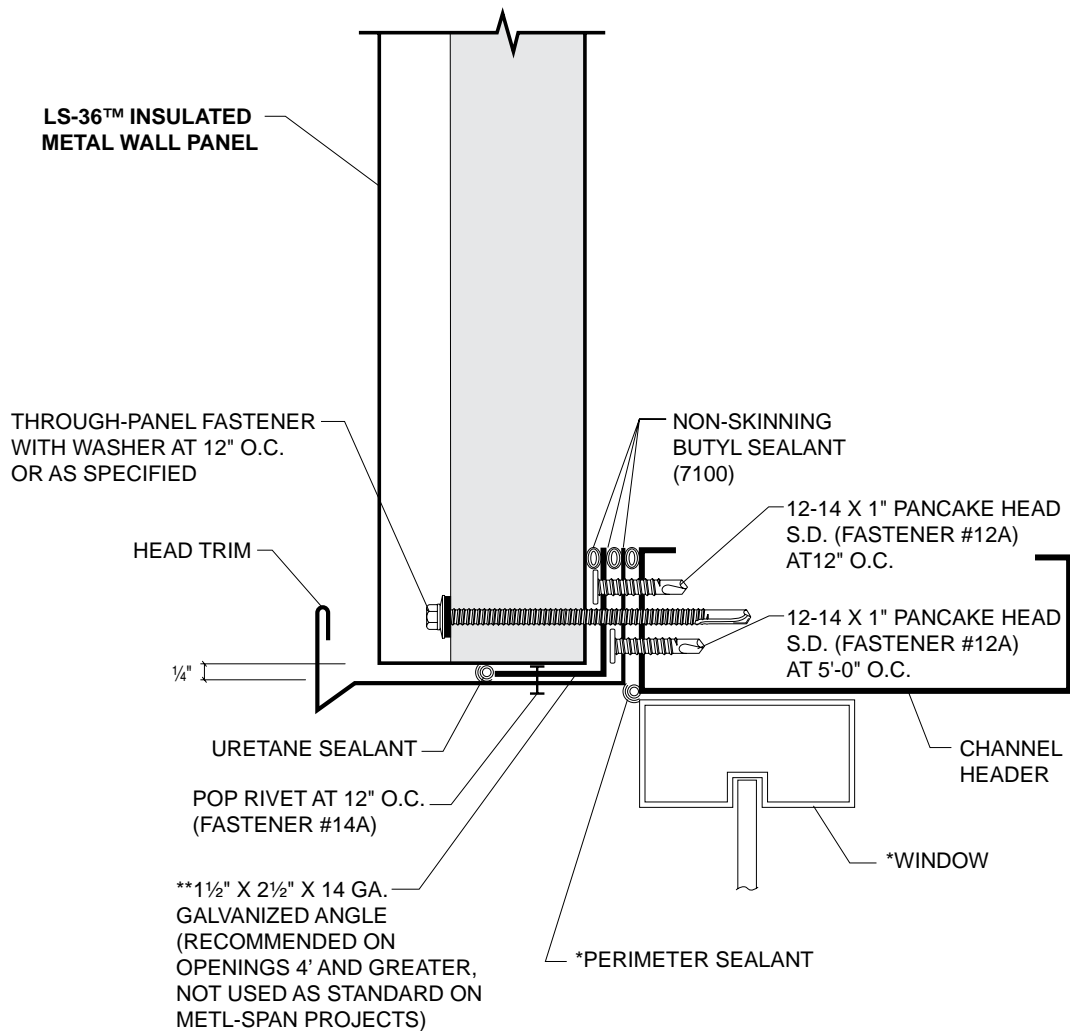

*NOT BY METL-SPAN

WINDOW SILL

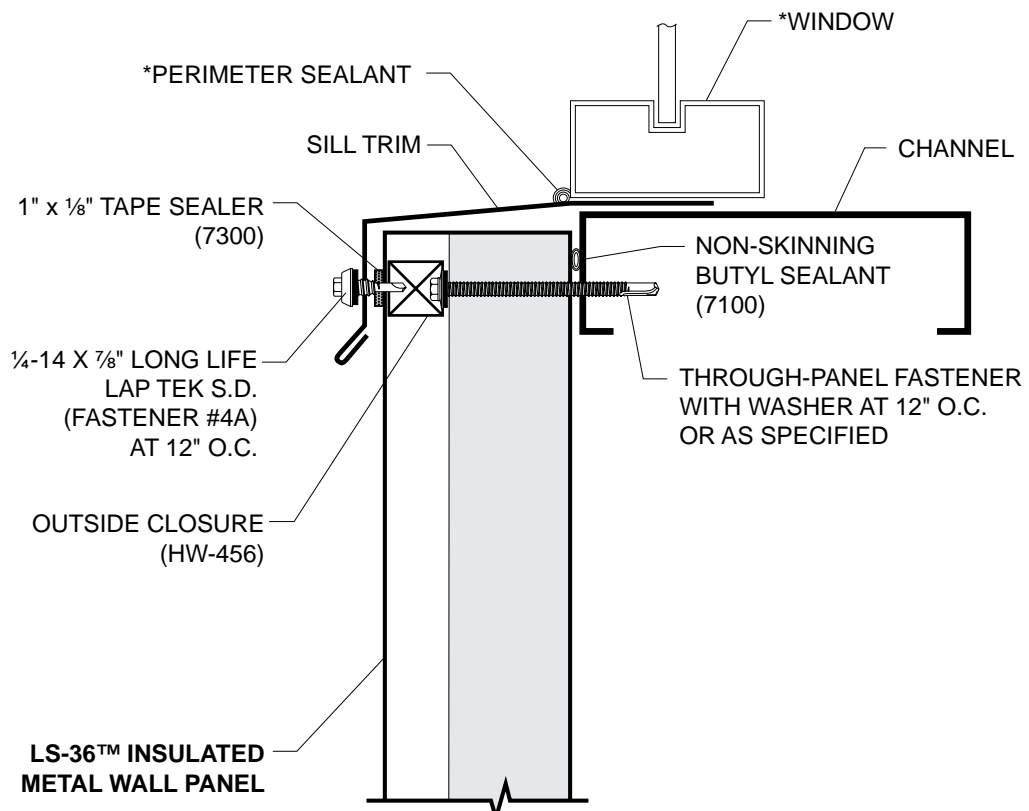

*NOT BY METL-SPAN

WINDOW JAMB

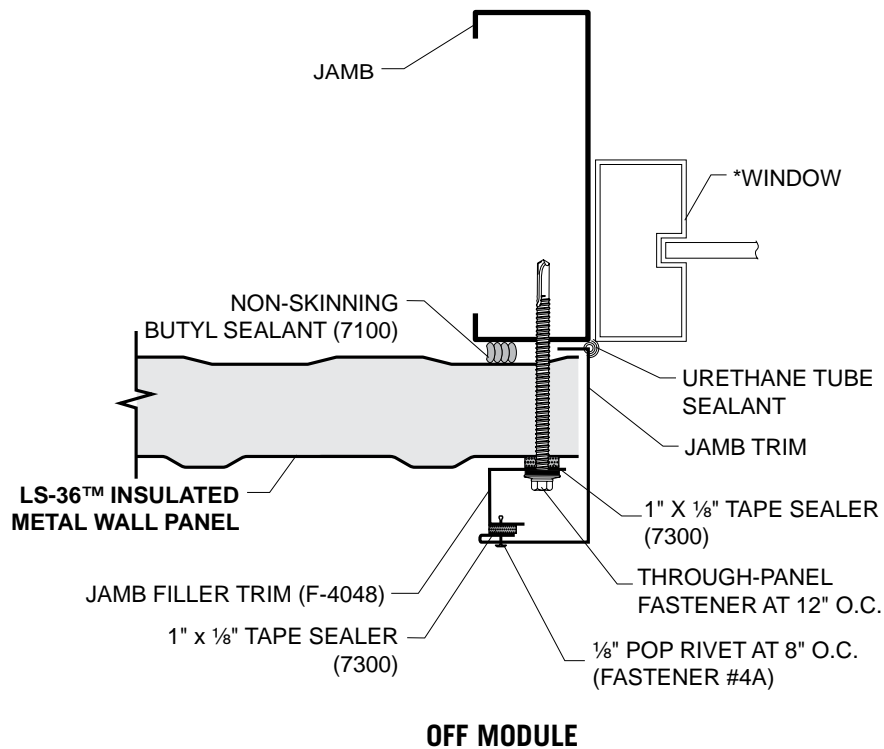
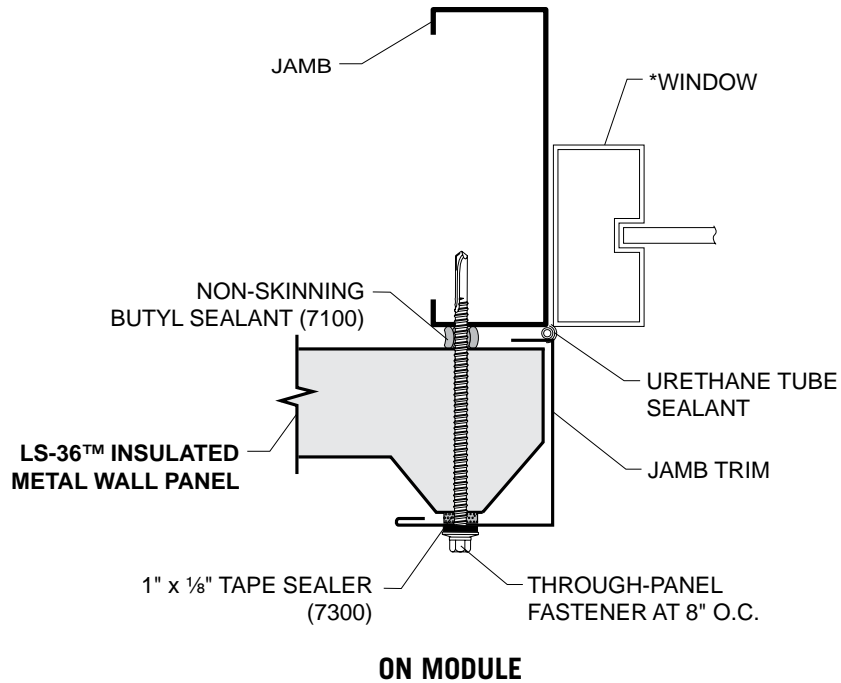

WALL STACK JOINT

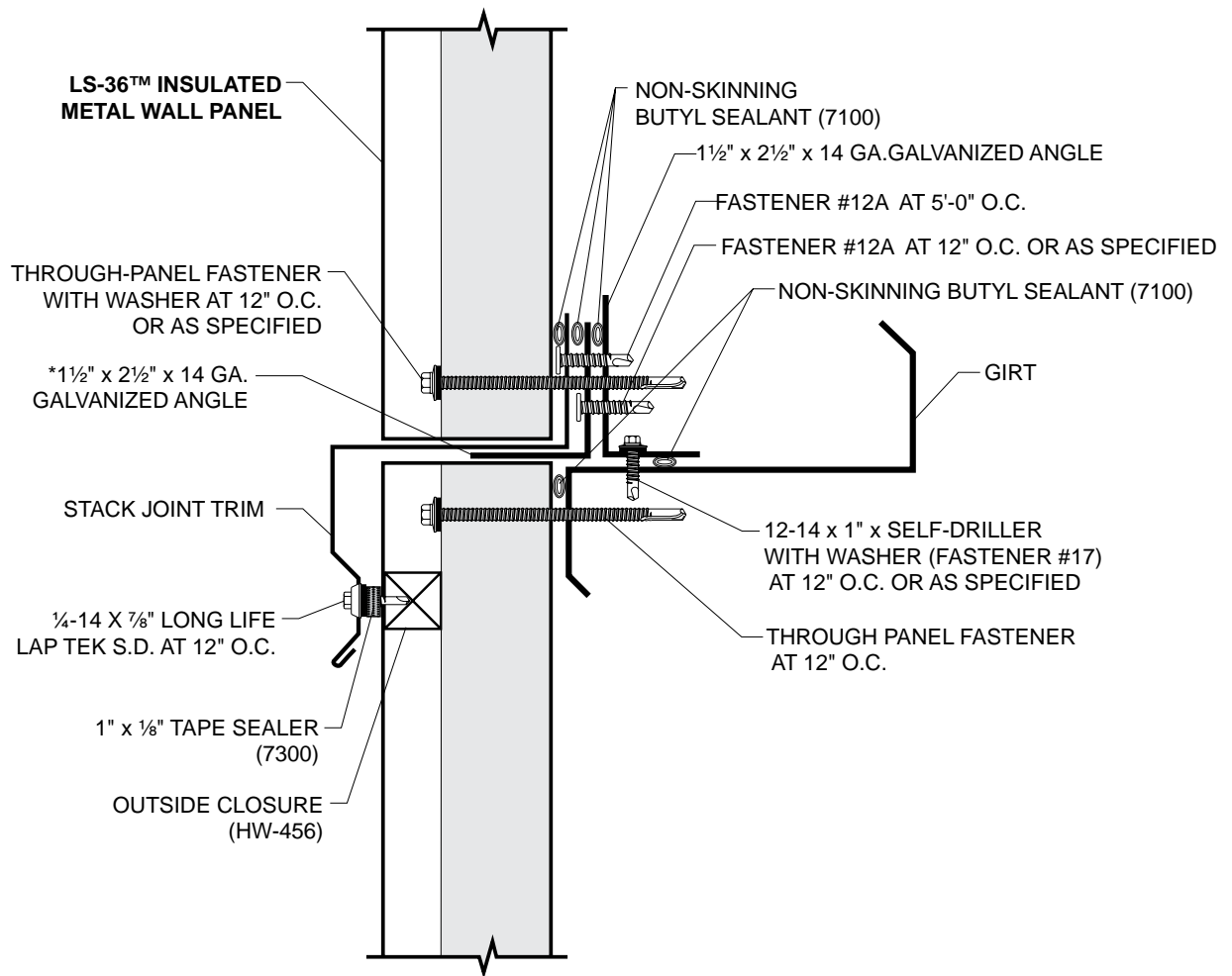

*NOT USED AS STANDARD ON METL-SPAN PROJECTS

WALL LAP

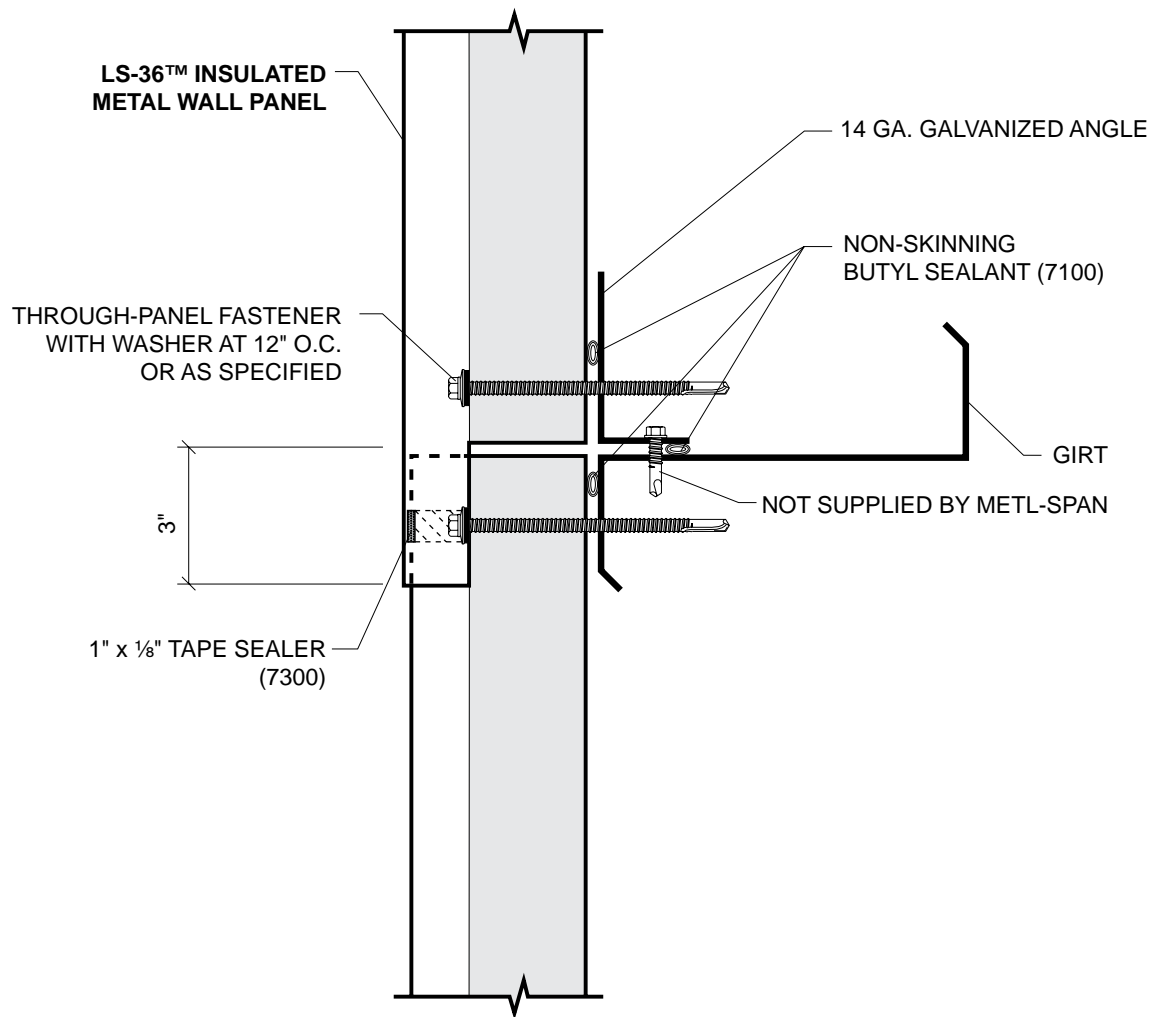

LS-36™ Insulated Metal Panel ROOF PANEL ORIENTATION

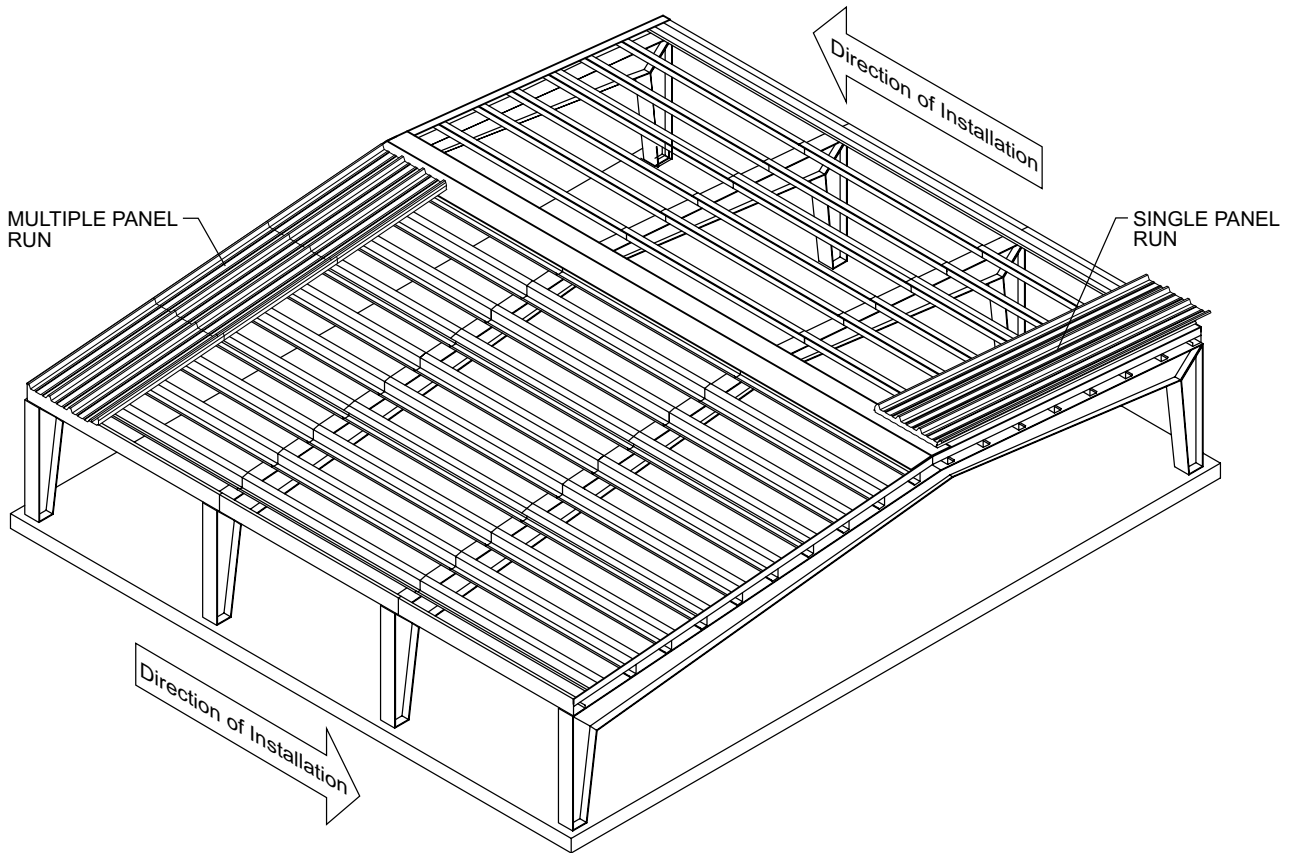
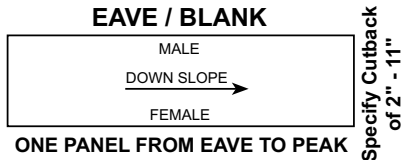

Specify Cutback of 2" - 11"

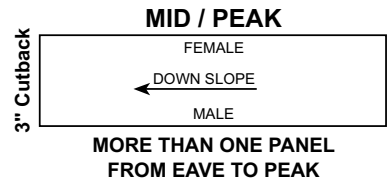
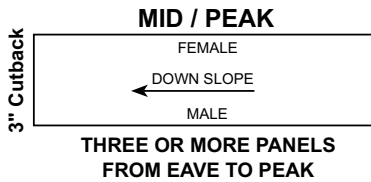
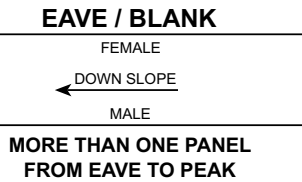

ROOF PANEL - FASTENER PATTERNS

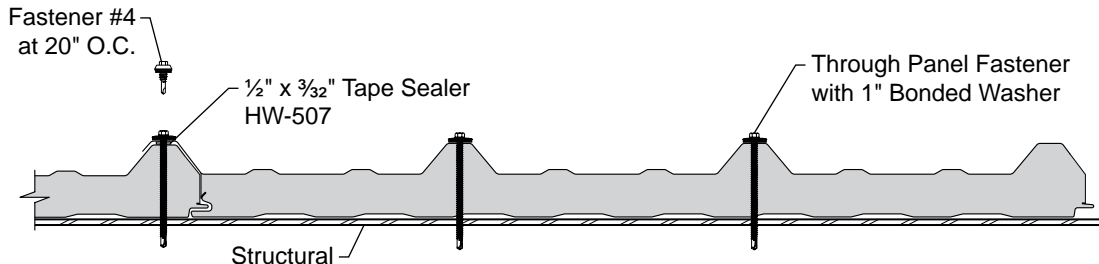

Fastener Patterns at Base, Intermediate and Ridge Structural

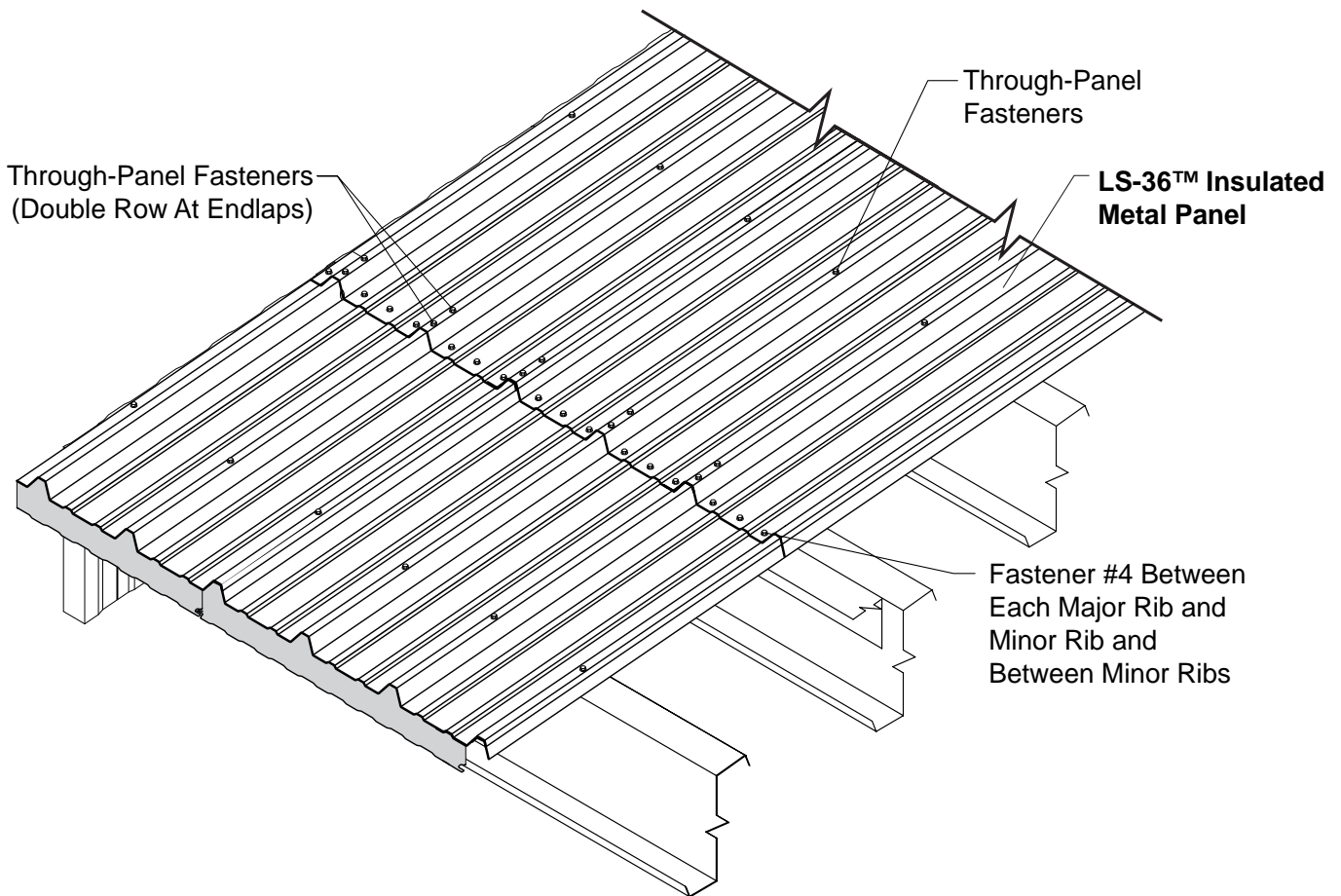

Fastener Pattern for End Laps

NOTES:

1. The above are typical fastener spacings. However, they may not be appropriate for all applications. Consult a professional engineer for use on any specific application.
2. Minimum 1/2" x 3/32" tape sealer required at panel side laps.
3. Side lap fasteners are required. Typical spacing is 20" O.C. However, this spacing may not be appropriate for all applications. Consult a professional engineer for use on any specific application.

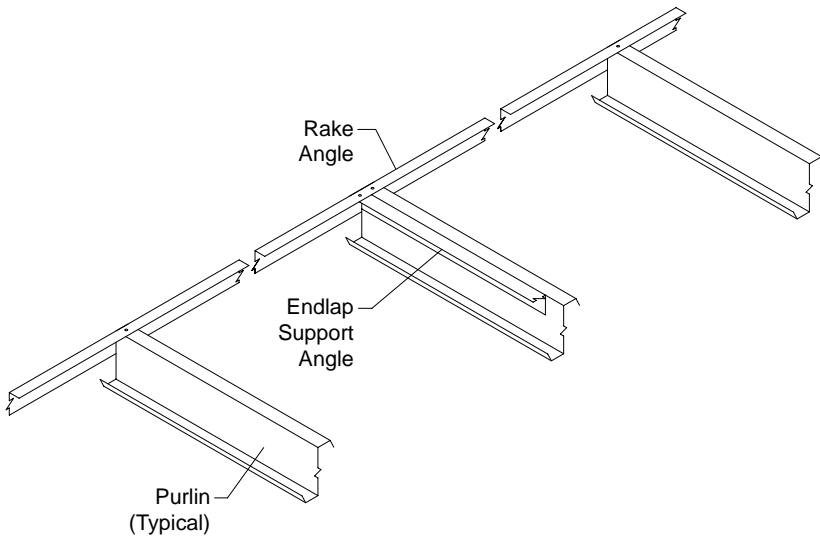

Rake Angle / Endlap Support Angle Installation

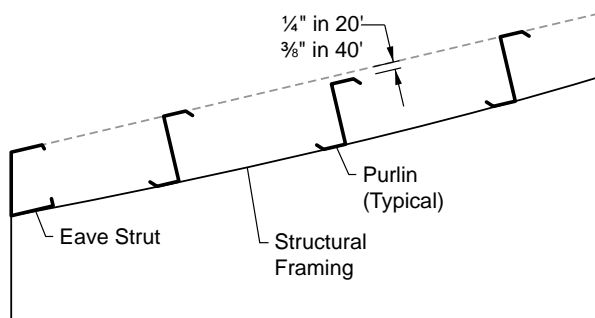

Acceptable Alignment

PREPARATORY REQUIREMENTS

Before beginning installation of **Metl-Span's LS-36™ Insulated Metal Panels**, verify that all structural framing and bracing has been installed and that all connection bolts have been installed and tightened. Purlins must be properly braced to prevent rolling.

A rake angle must be installed on top of the secondary structurals to provide a seal line along the rake of the roof.

If the roof has endlaps, an additional structural support must be installed at all endlap locations. **It is critical that these endlap supports are installed at the exact location specified on the drawings.**

Check to ensure that the steel framing is plumb and that it is "in plane" from eave to ridge. An out-of-plane substructure will force the panels to bend when the panels are fastened, causing oil-canning and difficulty engaging the next panel. Tolerances for substrate alignment are as follows: 1/4" in 20' or 3/8" in 40', with no more than 1/16" between any two consecutive structural members.

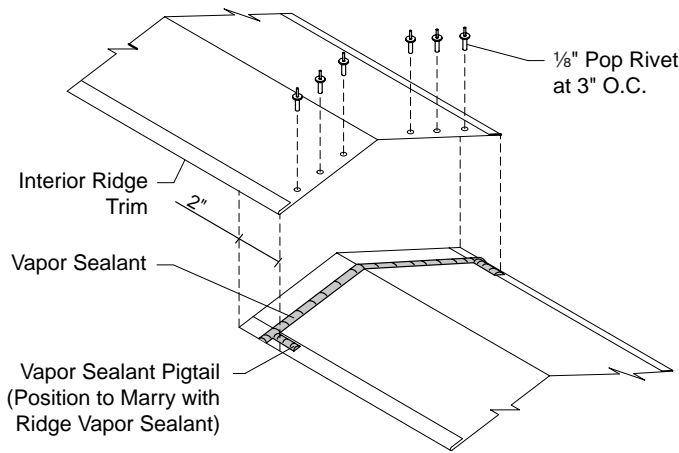
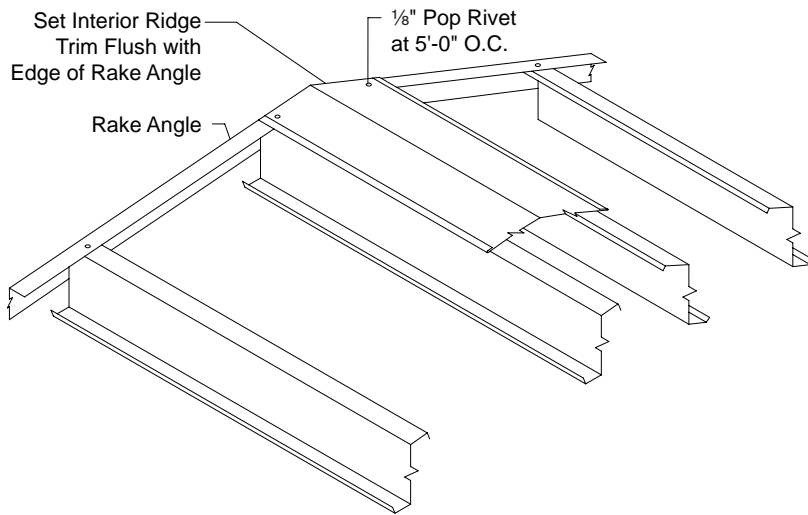

Typical Trim Lap

PREPARATORY REQUIREMENTS (continued)

Before panels can be installed, ensure that all applicable interior trim that may be required at ridge, eave or rake are installed as shown on the project drawing. Any areas that require a sealant bead for a vapor sealant must be contiguous.

Interior Ridge Trim Vapor Sealant

The interior ridge trim must be installed before the vapor sealant and roof panels are installed.

Position the trim so that it is centered over the ridge structurals.

Align the end of the trim flush with the outer edge of the rake structural.

Fasten the trim to the structurals with 1/8" diameter pop rivets as necessary to secure the trim until the roof panels are installed.

At trim splices, apply vapor seal caulk, lap trim 2" and secure lap with pop rivets at 3" o.c. and centered over vapor sealant.

PREPARATORY REQUIREMENTS ROOF (continued)

Eave and Rake

At the eave or rake, if any gaps in the structural framing are present, install a piece of joint flashing to provide a continuous surface to allow for a complete seal along the roof's perimeter.

Note: Are not specified or provided by Metl-Span®.

Apply continuous beads of vapor seal caulk along the rake and eave structurals and along the ridge flashing.

To avoid damage or contamination of the caulk, do not apply until immediately before installation of the next roof panel and apply only as much caulk as needed for that panel.

Apply the caulking bead large enough to assure filling the roof panel's interior face mesa ribs.

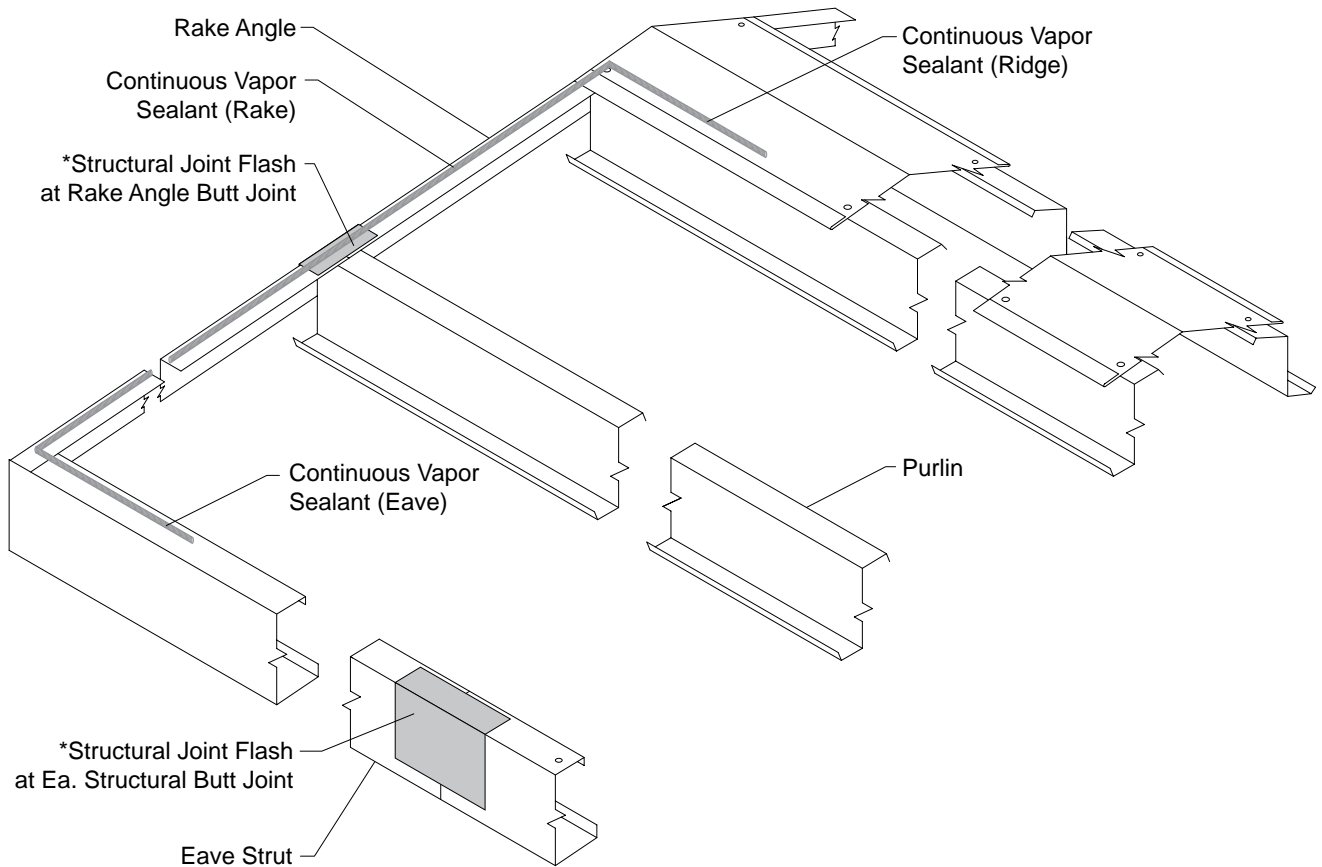

Perimeter Seal

***NOT BY METL-SPAN**

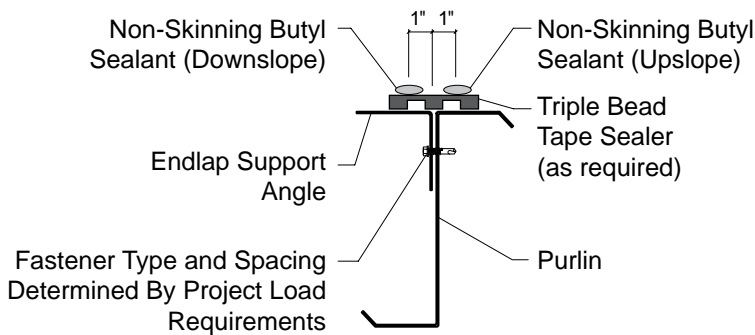
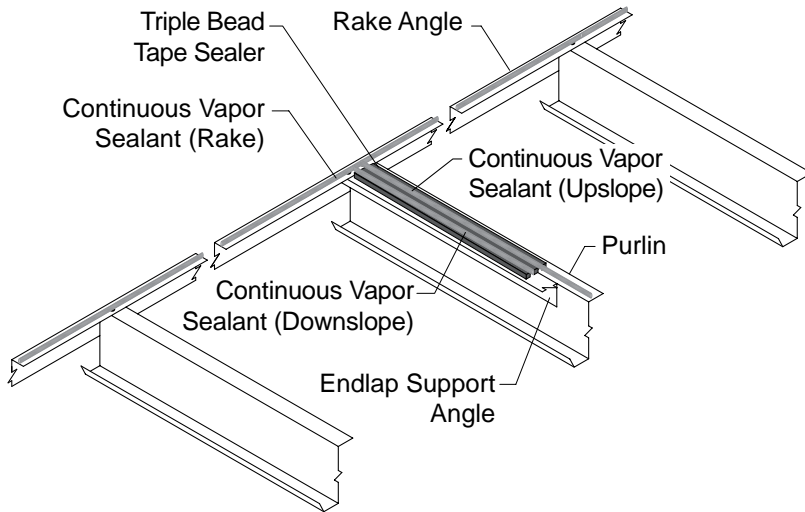

Endlap Vapor Sealant Locations

PREPARATORY REQUIREMENTS (continued)

Endlap Vapor Sealant

Apply triple bead tape sealer along the joint between the purlin and the endlap support angle. Apply continuous beads of non-skinning butyl sealant upslope and downslope of the center of the endlap support angle on top of the triple bead tape sealer.

To avoid damage or contamination of the caulk, do not apply until immediately before installation of the next roof panel and apply only as much caulk as needed for that panel.

Apply the caulking bead large enough to assure filling the roof panel's interior face mesa ribs.

Assure that the support structural joints have been vapor sealed. **Note:** These seals are not specified or provided by Metl-Span®.

CAUTION

Diaphragm capabilities are not provided by the LS-36™ Insulated Metal Panel roof system. Therefore other bracing maybe required.

ROOF PANEL LAYOUT

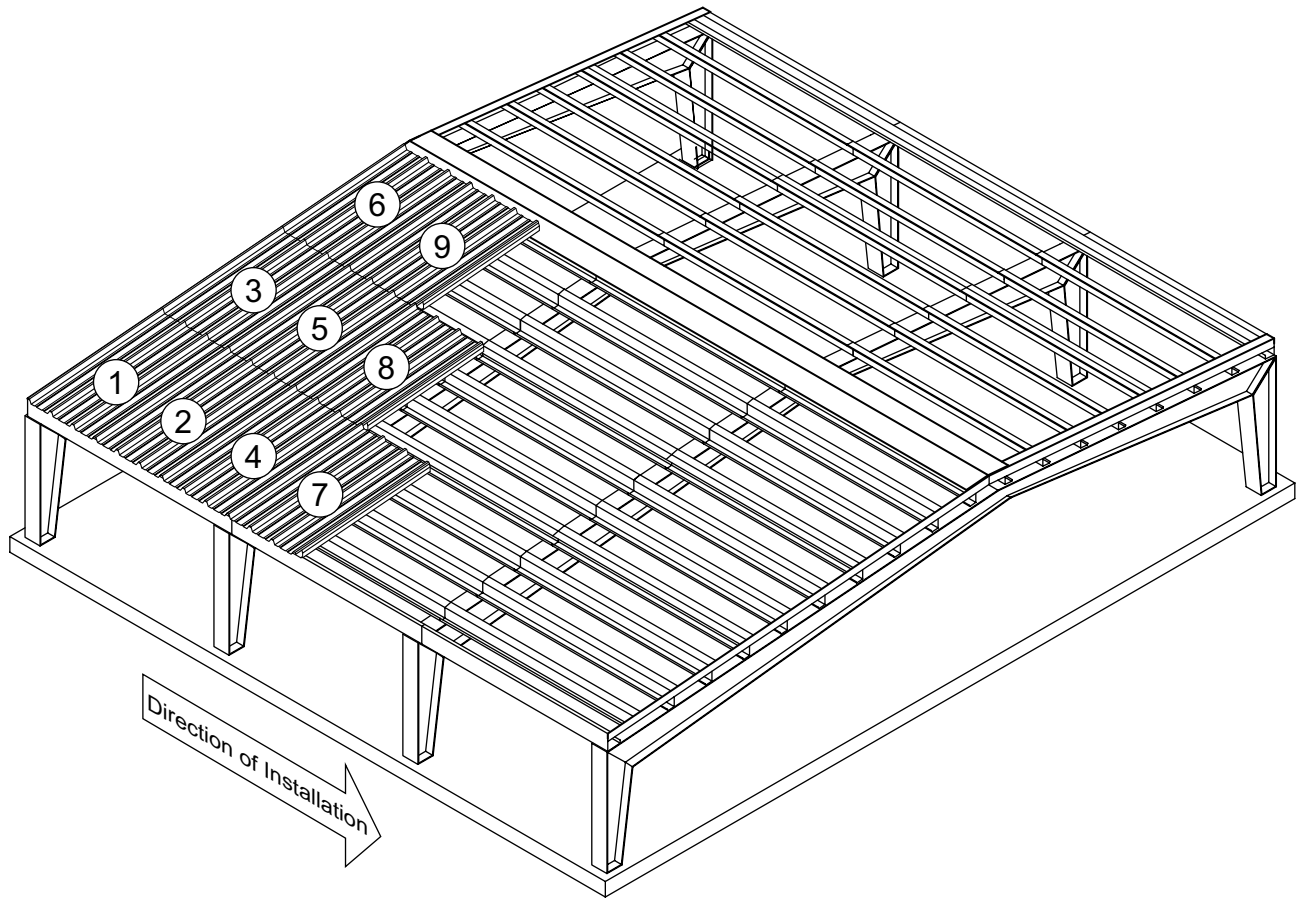

STEP 1

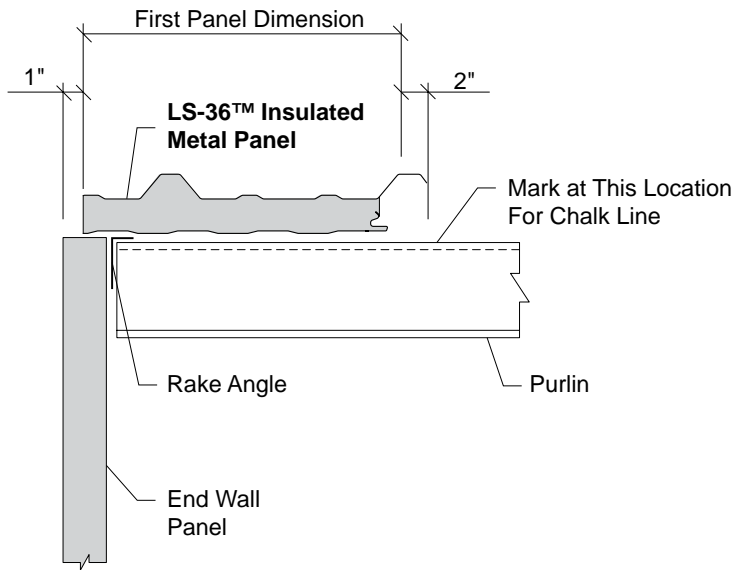
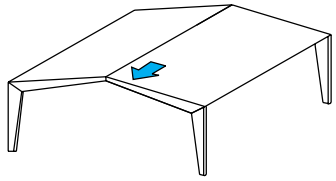

First Panel Section Cut

PREPARATION FOR FIRST PANEL RUN

Ensure that rake angle, interior ridge flashing, structural joint flashing and endlap structural supports have been installed as shown on the construction drawings. **(See Preparatory Requirements on page 69 – 72.)** If your roof does not require endlaps, omit the steps required for endlaps.

Refer to the construction drawings to determine the width of the first panel run. Cut all panels for the first run to this dimension, measuring from the center of the female leg. **Panels will be installed from left to right when standing at the eave and looking upslope.**

Measuring from the outside edge of the rake angle, mark the start dimension at the eave and the ridge and snap a chalk line between them. Check this line to ensure that it is square with the eave. Panels must be square to the eave to prevent "saw tothing" as you progress with the roof installation.

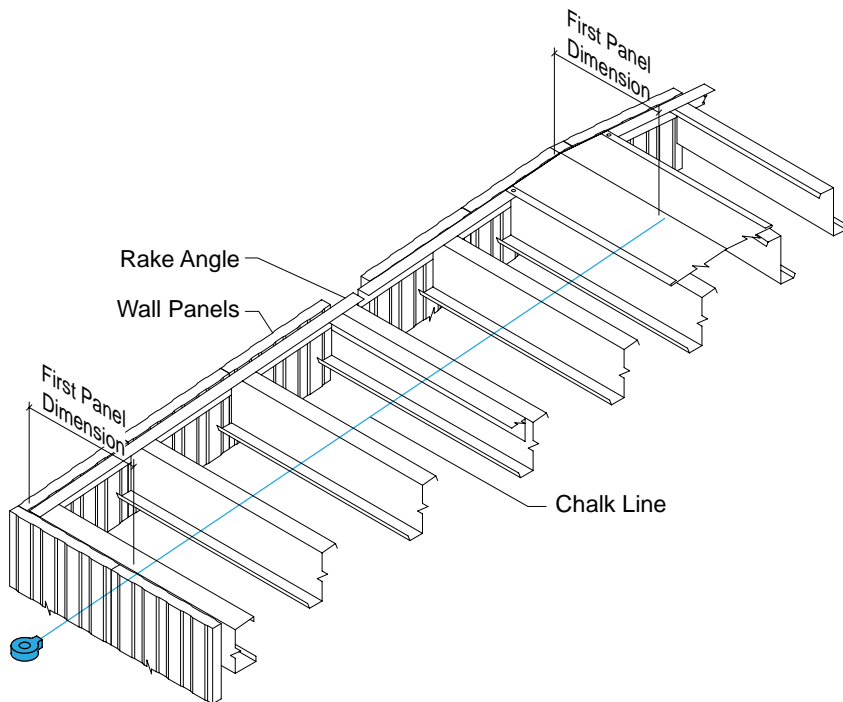

First Panel Chalk Line

**STEP
1
CONT'D.**

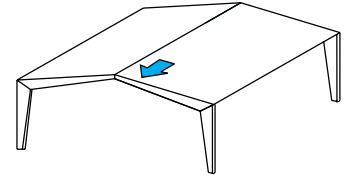

**PREPARATION FOR
FIRST PANEL RUN
(continued)**

Apply non-skinning butyl sealant along the length of the rake angle, beginning at the eave and moving upslope to approximately 3" longer than the length of the first panel. Apply non-skinning butyl sealant along the eave for a distance equal to the starting panel width plus 3". At the end lap, apply triple bead tape sealer along the joint between the end lap purlin and the end lap support angle. Then apply non-skinning butyl sealant on top of the triple bead tape sealer just down slope from the center of the triple bead tape sealer.

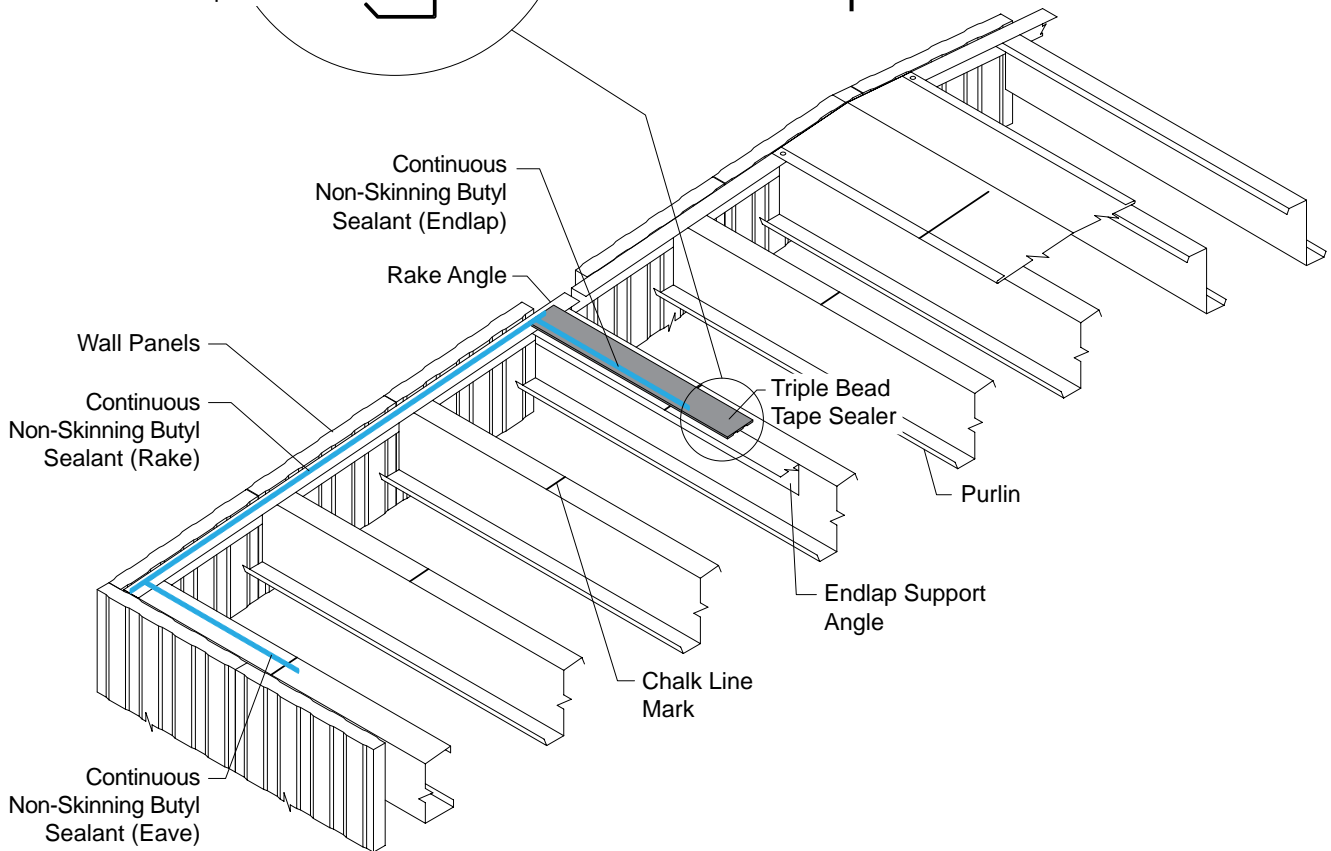
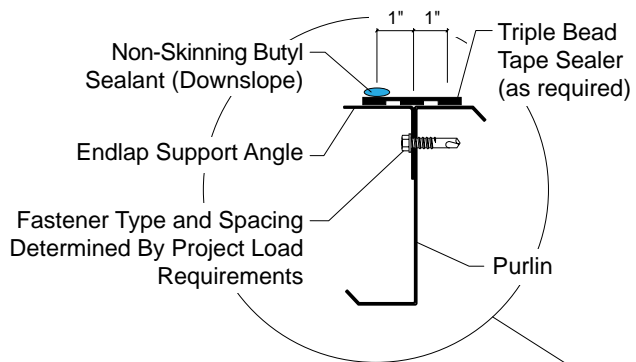

First Panel Vapor Sealant

INSTALLATION SEQUENCE

LS-36™ INSULATED METAL ROOF & WALL PANEL

**STEP
1
CONT'D.**

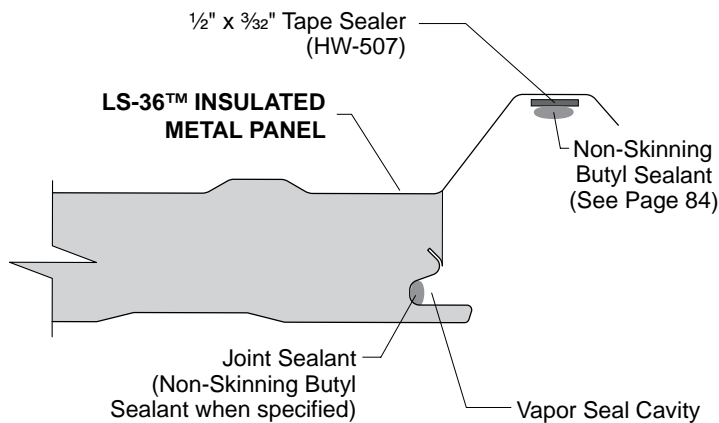
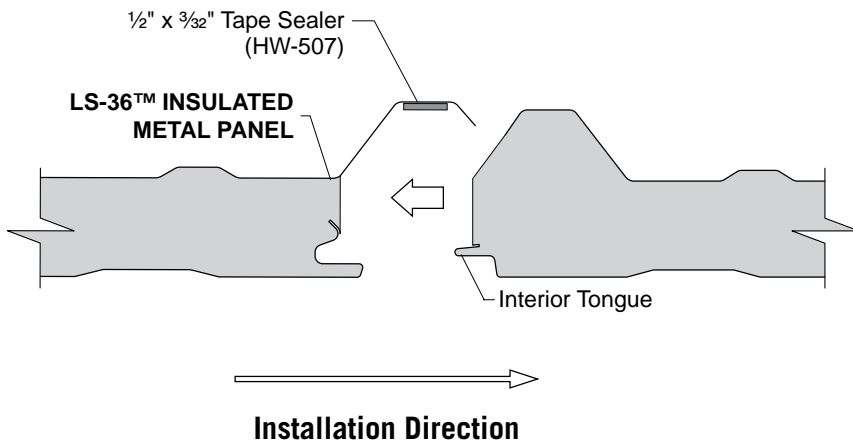
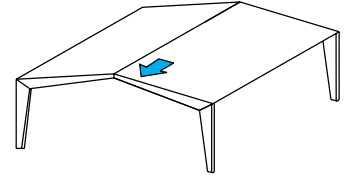

Joint Sealant Application

PREPARATION FOR FIRST PANEL RUN (continued)

The panels will be installed backwards when compared to single skin R panel installation procedure. Because of this, it is best to turn the panel upside down and install 1/2" x 3/32" butyl tape sealant to the underside of the panel side lap.

If vapor sealant is specified, apply a 1/4" bead of non-skinning butyl into the vapor groove cavity of the panel.

INSTALLATION SEQUENCE

LS-36™ INSULATED METAL ROOF & WALL PANEL

STEP 2

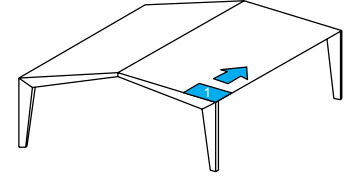

FIRST PANEL INSTALLATION

Set the first panel at the eave in place with the leading edge of the panel aligned with the chalk mark. The cut edge of the panel should be approximately 1" short of the face of the end wall panel. Fill any voids between wall and roof with blanket insulation or field applied foam.* Consult the construction drawings for the overhang at the eave. This dimension is typically 2" (3" panel cutback) but special conditions may dictate another dimension.

*Not supplied by Metl-Span®.

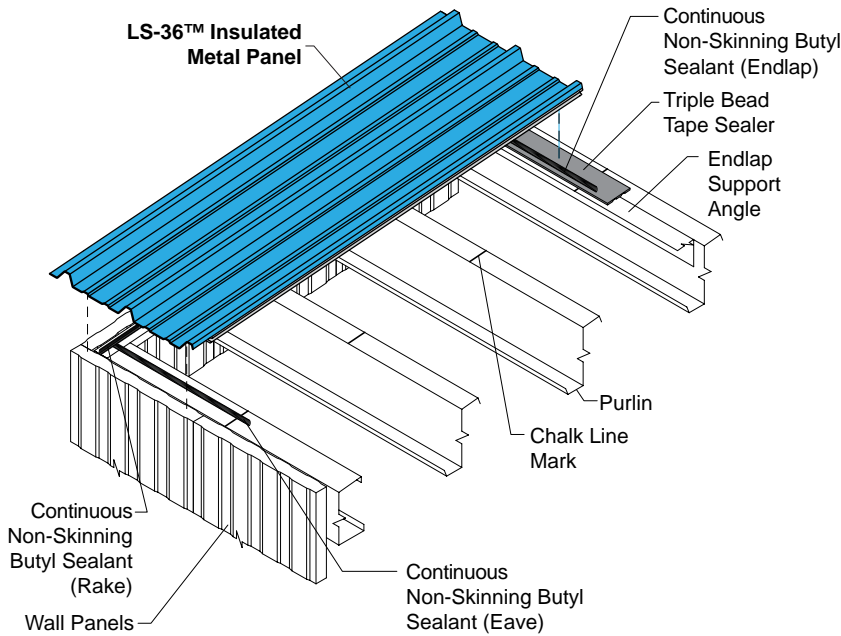

First Panel Installation

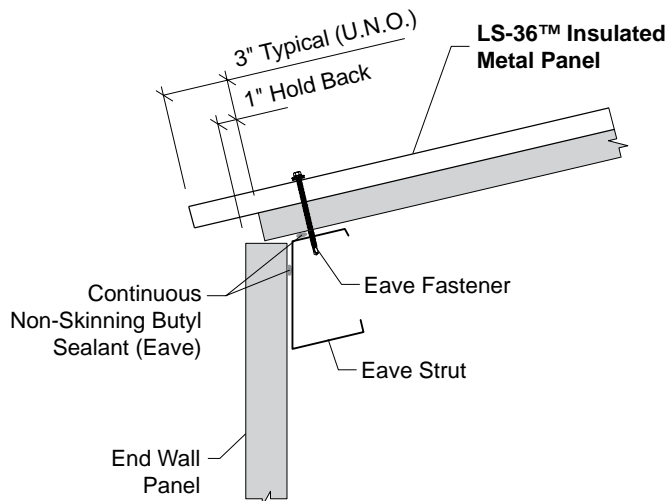

First Panel Eave Section

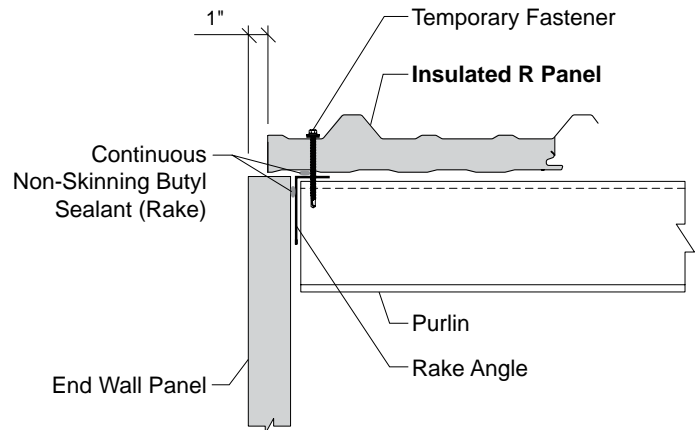

First Panel Rake Section

**STEP
2
CONT'D.**

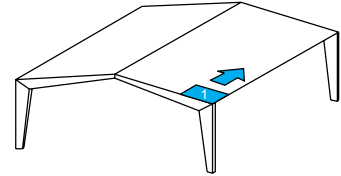

**FIRST PANEL
INSTALLATION
(continued)**

Temporarily fasten the cut edge of the panel to the rake angle. Install fasteners through the panel high ribs at each structural support. Do not install fasteners at the end lap structural at this time. These fasteners will be installed after the end lap has been made.

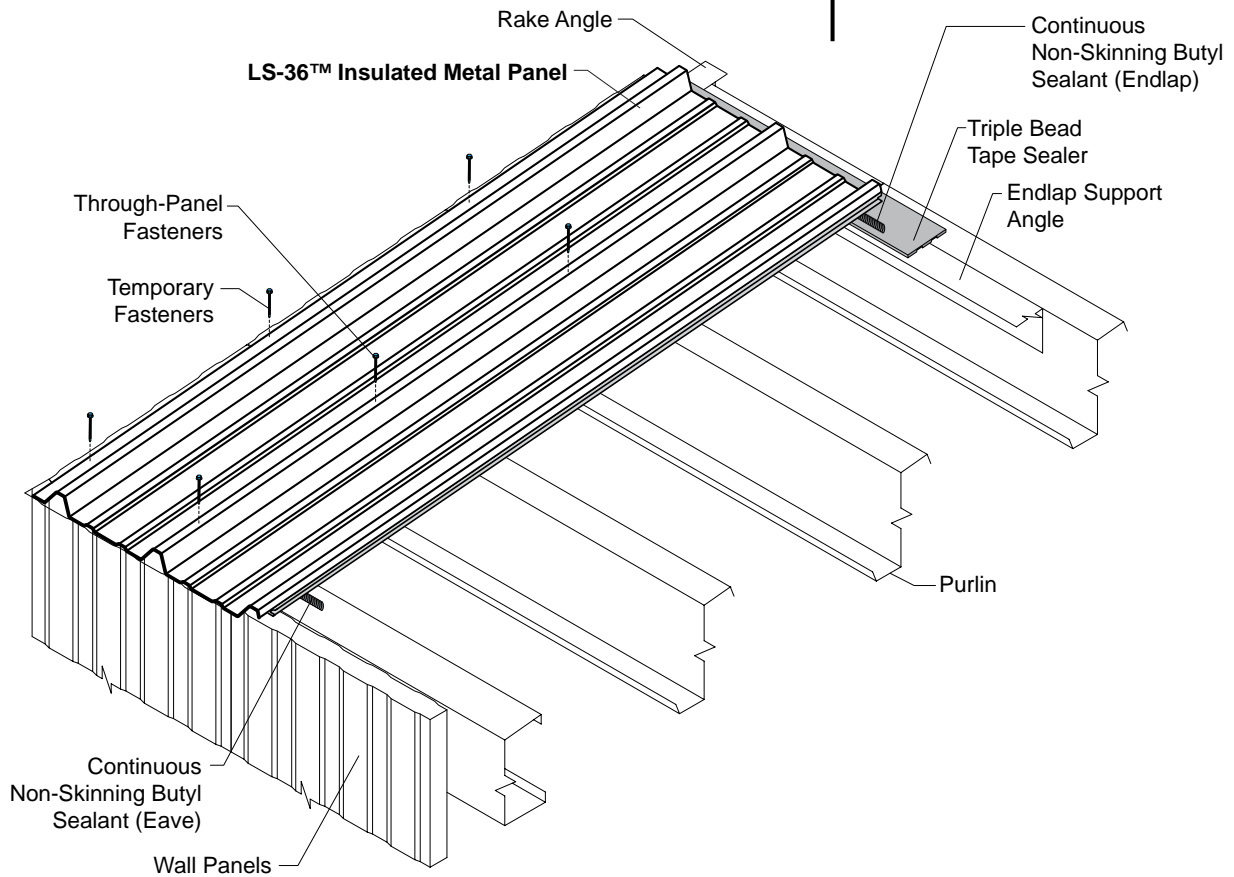

First Panel Fastened

INSTALLATION SEQUENCE

LS-36™ INSULATED METAL ROOF & WALL PANEL

**STEP
3**

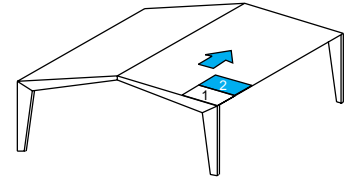

SUBSEQUENT RUNS-EAVE

Apply non-skinning butyl sealant along the eave structural and at the end lap structural. Apply additional triple bead tape sealer and additional non-skinning butyl sealant to allow for the next panel installation at the eave. At the eave and end lap structurals, apply a non-skinning butyl sealant pigtail from the top of the male rib of the previously installed panel, down to the sealant in the panel groove and on down to the sealant on the eave strut or end lap structural.

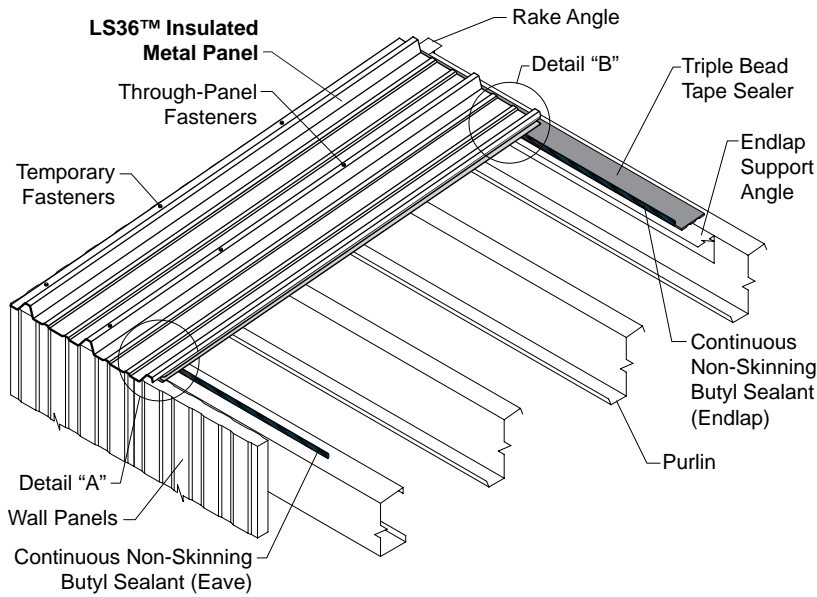

Subsequent Runs Eave Panel Sealant

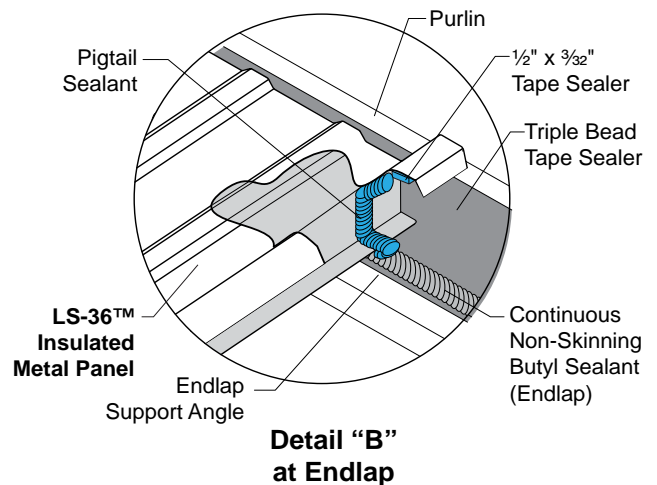
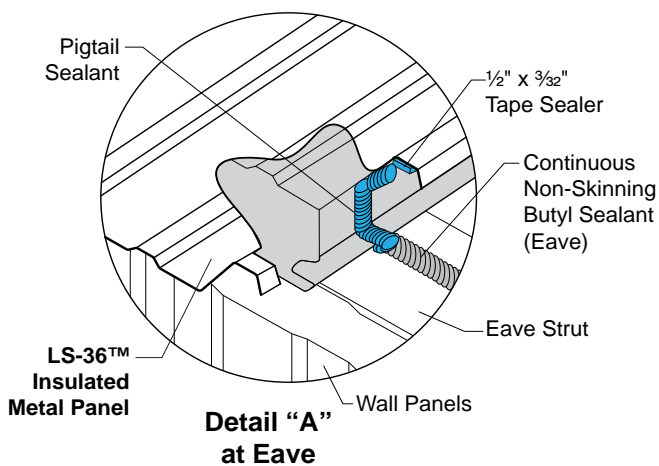

Subsequent Runs Pigtail Sealant

INSTALLATION SEQUENCE

LS-36™ INSULATED METAL ROOF & WALL PANEL

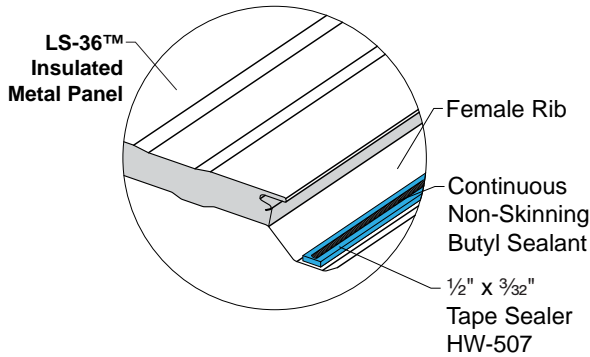

Sidelap Sealant

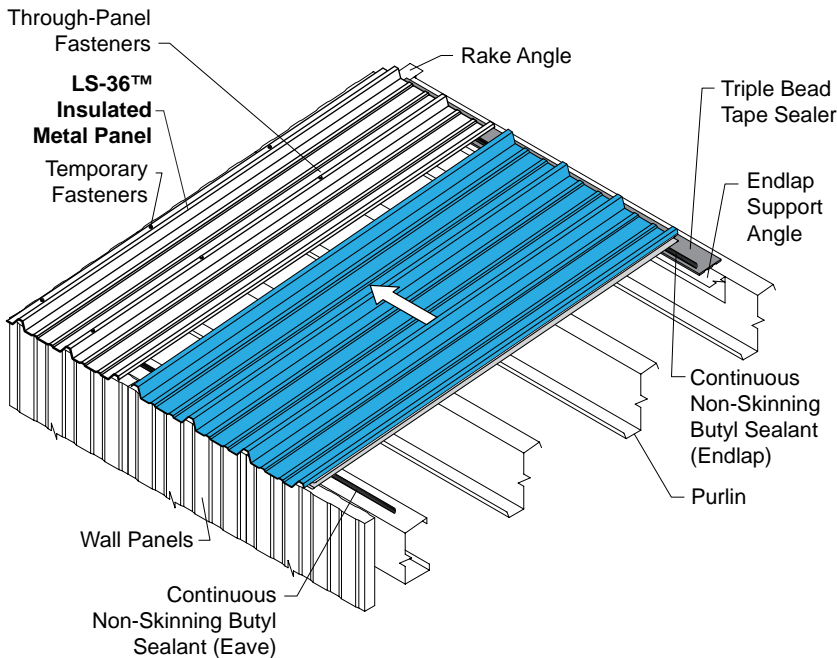

Subsequent Runs Eave Panel

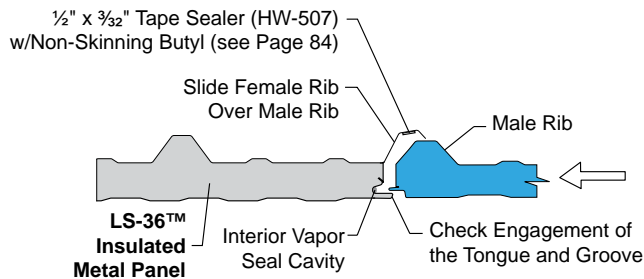

Subsequent Runs Sidelap Engagement

**STEP
3
CONT'D.**

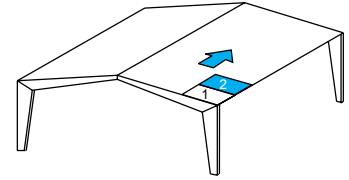

SUBSEQUENT RUNS-EAVE (continued)

Turn the next panel to be installed upside down. Apply 1/2" x 3/32" tape sealant to the bottom side of the female rib along the full length of the panel. Turn the panel back over and align the eave end of this panel with the end of the previous panel.

Push the male leg of the panel under the female leg of the previous panel to provide a proper engagement of the sidelap and to fully engage its tongue into the groove of the previous panel.

INSTALLATION SEQUENCE

LS-36™ INSULATED METAL ROOF & WALL PANEL

**STEP
3
CONT'D.**

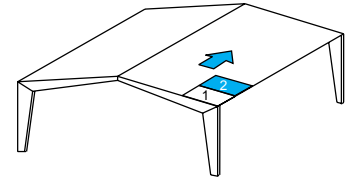

SUBSEQUENT RUNS-EAVE (continued)

Check the overhang at the eave to ensure that it is 2" beyond the face of the wall (or the dimension specified in the construction drawings).

Install fasteners at all structurals except the end lap structural as previously described.

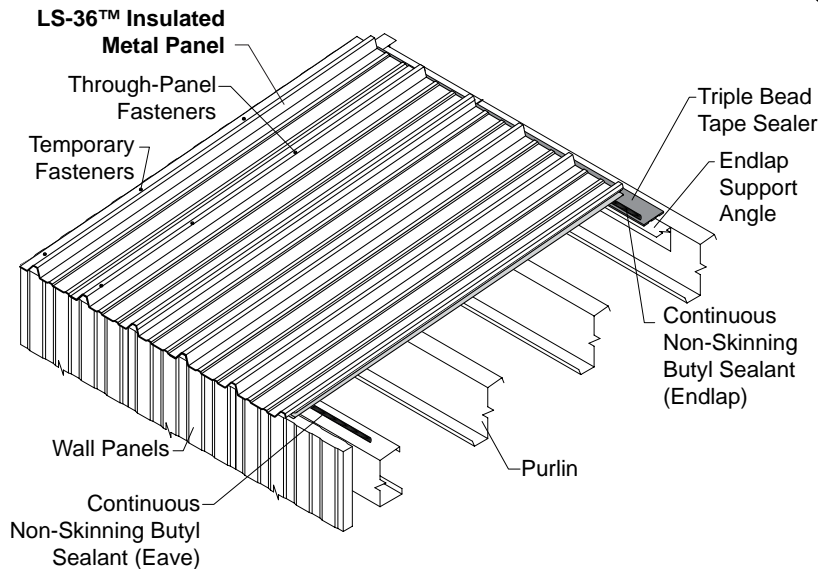

Subsequent Runs Eave Panel Installed

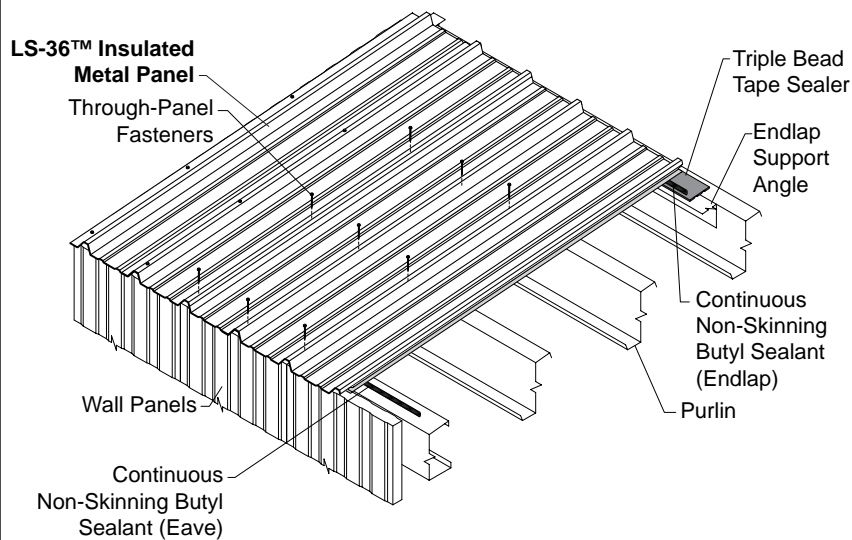

Subsequent Runs Eave Panel Fastened

INSTALLATION SEQUENCE

LS-36™ INSULATED METAL ROOF & WALL PANEL

STEP 4

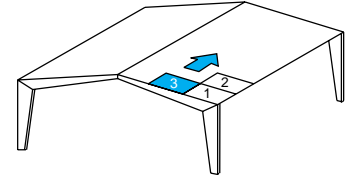

ENDLAP

Apply non-skinning butyl sealant to the rake angle to extend 3" past the next panel upslope. Also apply non-skinning butyl sealant to the upslope half of the triple bead tape sealer. At the next endlap, apply triple bead tape sealer along the joint between the endlap purlin and the endlap support angle. Then apply non-skinning butyl sealant on top of the triple bead tape sealer just down slope from the center of the triple bead tape sealer.

At the upslope end of the eave panel, apply triple bead tape sealant across the width of the panel, conforming tape sealant to the panel profile. For proper placement along the length of the panel, align the edge of the paper with the upper edge of the panel. Then apply a bead of non-skinning butyl sealant across the top of the triple bead tape sealer.

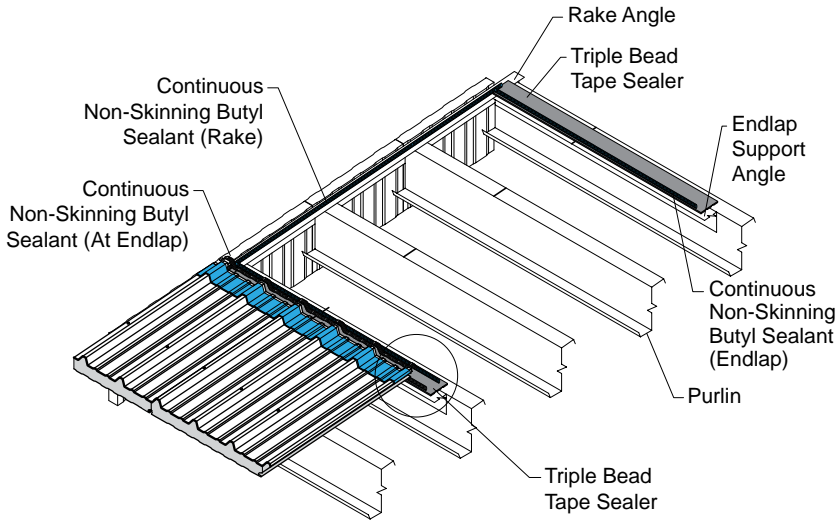

Endlap Panel Sealant

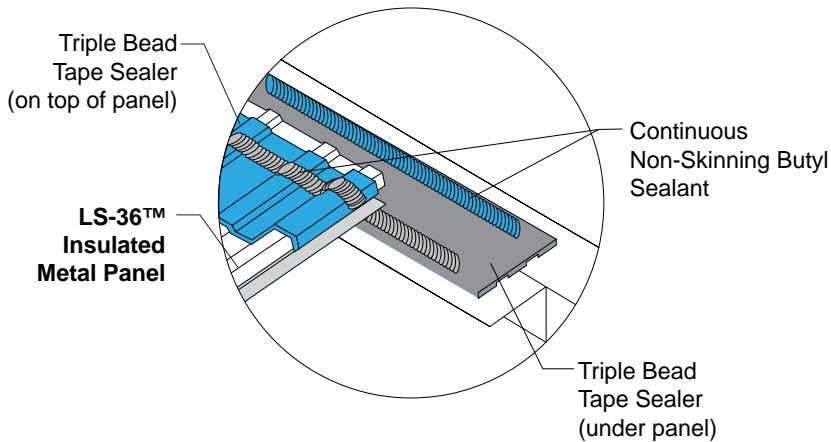

Endlap Installation

INSTALLATION SEQUENCE

LS-36™ INSULATED METAL ROOF & WALL PANEL

STEP 4 CONT'D.

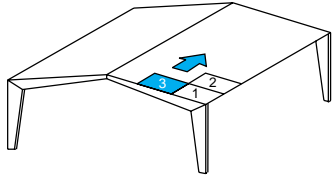

ENDLAP (continued)

Position the upslope panel so that its interior skin and foam butts the interior skin and foam of the downslope panel and set down, into place. At the upslope end, make sure the panel is aligned with the chalk mark and install fasteners through the major ribs of the panels at each structural location, including a double row at the end lap location.

Install Fastener #4 between each major rib and minor rib and between minor ribs.

To complete the seal between the panels and the structure, apply a vapor sealant pigtail, marrying the vapor sealant in the panel groove to the vapor sealant on the endlap purlin and to the endlap support angle.

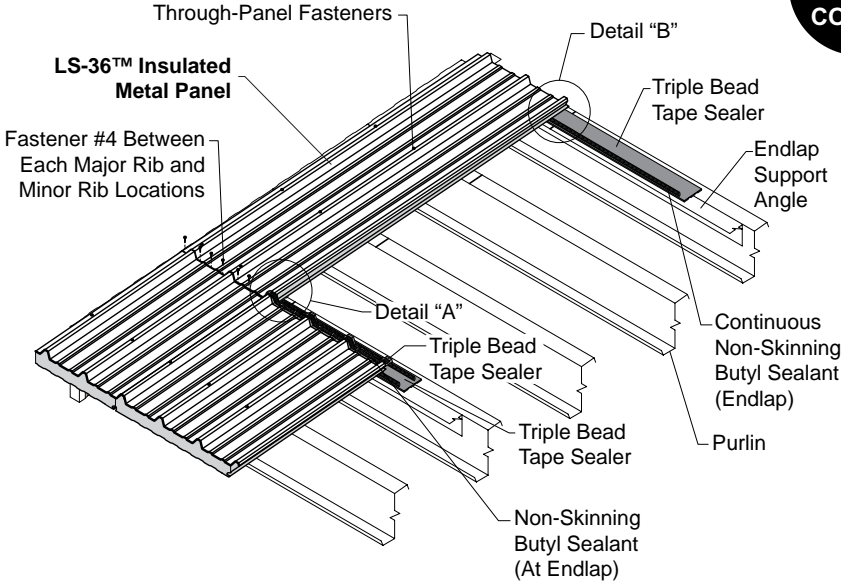

Endlap Panel Attachment

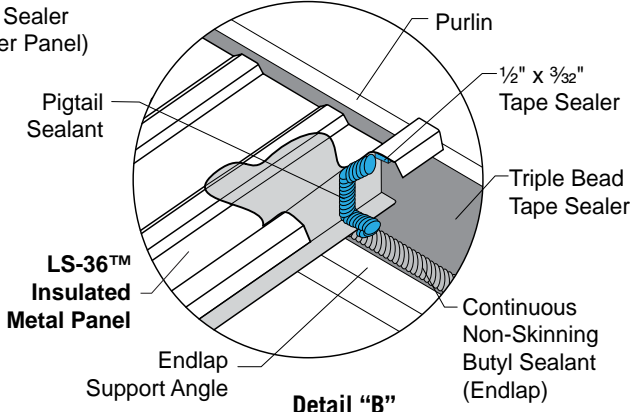
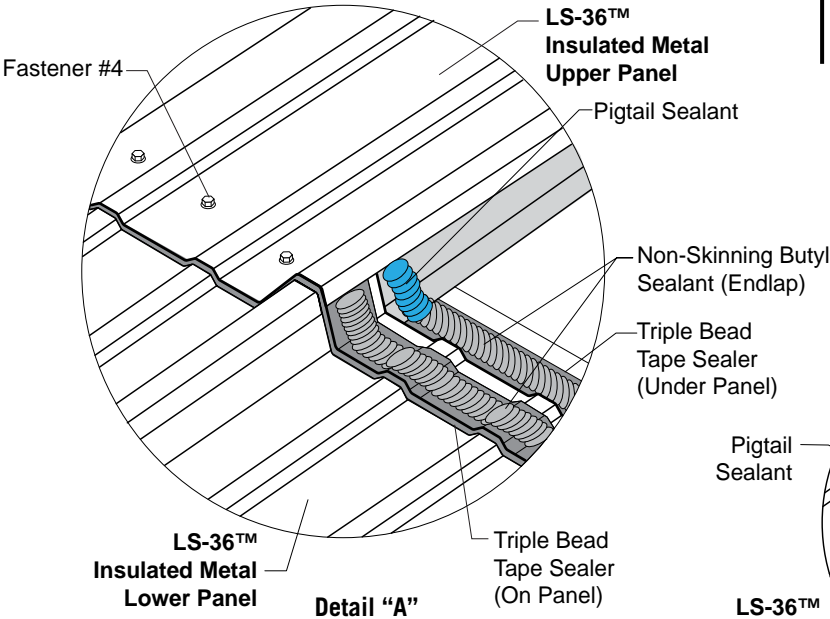

Endlap Pigtail Sealant

STEP 5

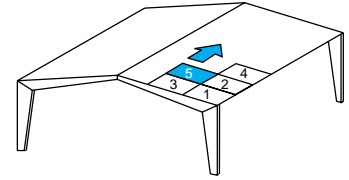

SUBSEQUENT RUNS-ENDLAP

At the upslope end of the eave panel, apply triple bead tape sealant and vapor sealants and pigtail sealants as previously described in Step 4.

Turn the next panel to be installed upside down. Apply 1/2" x 3/32" tape sealant to the bottom side of the female rib along the full length of the panel. Also apply a small bead of non-skinning butyl on top of the tape sealer. Turn the panel back over and position the upslope panel so that its interior skin is approximately 1/4" upslope from the interior skin of the downslope panel. Tilt the panel to engage its male leg under the female leg of the previous panel. Lower the male side of the panel and push to fully engage the tongue into the groove of the previous panel. Lift downslope end of panel and slide panel downslope until the foam butts the foam of the eave panel.

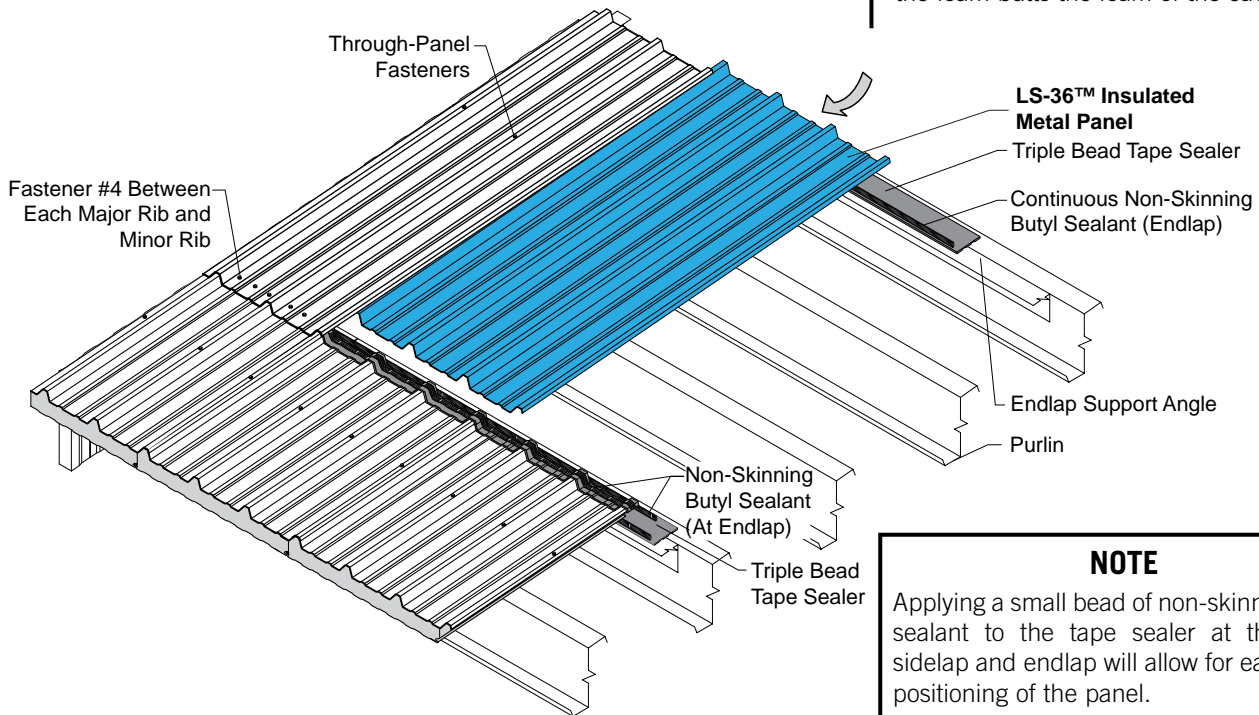
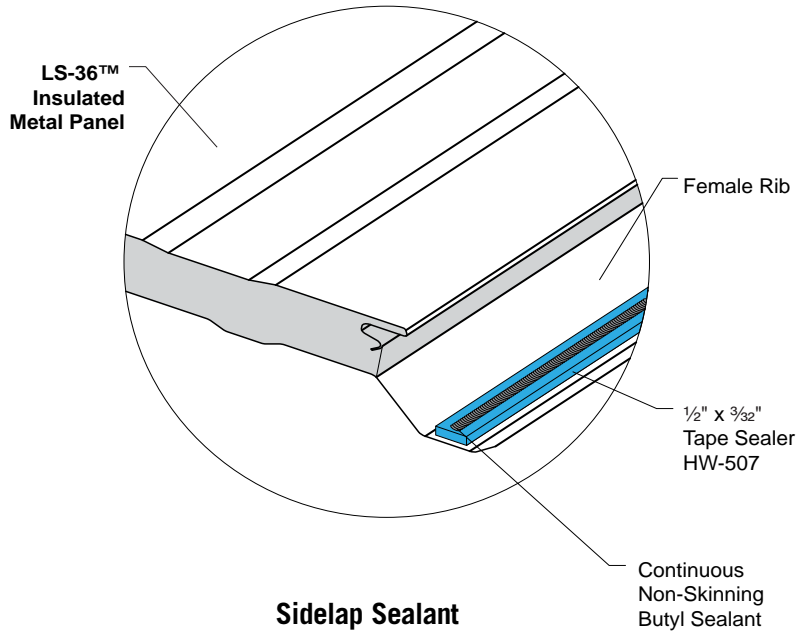

NOTE

Applying a small bead of non-skinning butyl sealant to the tape sealer at the panel sidelap and endlap will allow for easier final positioning of the panel.

**STEP
5
CONT'D.**

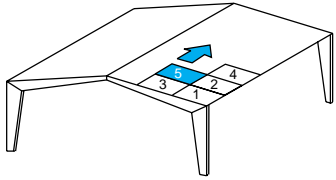

**SUBSEQUENT
RUNS-ENDLAP
(continued)**

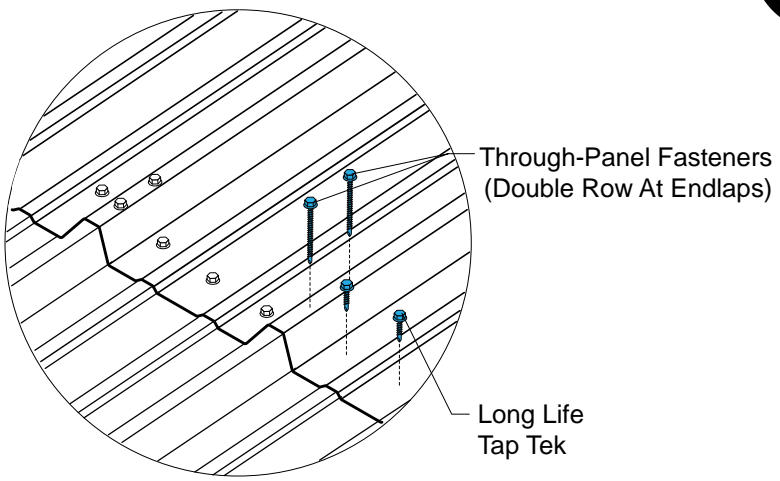

Detail "A"

Check to ensure that the panel tongue is fully engaged into the previous panel's groove.

Install fasteners through the major ribs of the panels at each structural location. Install Fastener #4 at the end lap on both sides of the major ribs and in between the minor ribs approximately 1½" upslope from the downslope edge of the upper panel.

Repeat this step with all endlap panels until the ridge panel is reached.

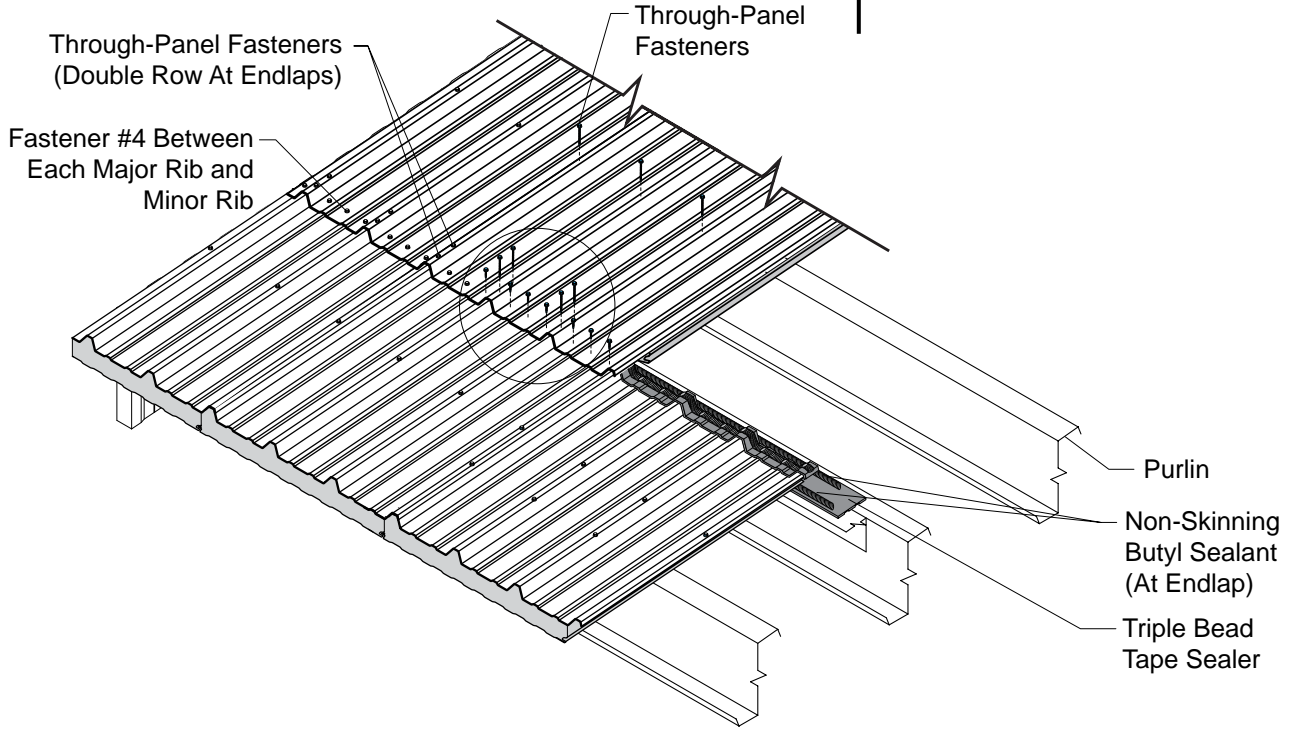

Subsequent Runs Endlap Panel Fastened

INSTALLATION SEQUENCE

LS-36™ INSULATED METAL ROOF & WALL PANEL

STEP 6

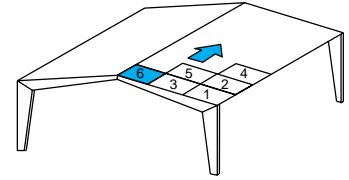

RIDGE PANEL

Apply non-skinning butyl sealant along the rake angle up to the interior ridge flashing and along the interior ridge trim to extend approximately 3" past the width of the panel run.

Install the ridge panel endlap as described in Step 5. Be sure to install fasteners at the ridge purlin. The upslope of the ridge panel should stop approximately 1" from the centerline of the ridge of the building unless noted.

To complete the seal between the panels and the structure, apply a vapor sealant pigtail, marrying the sealant in the panel groove to the sealant on the endlap purlin and to the endlap support angle.

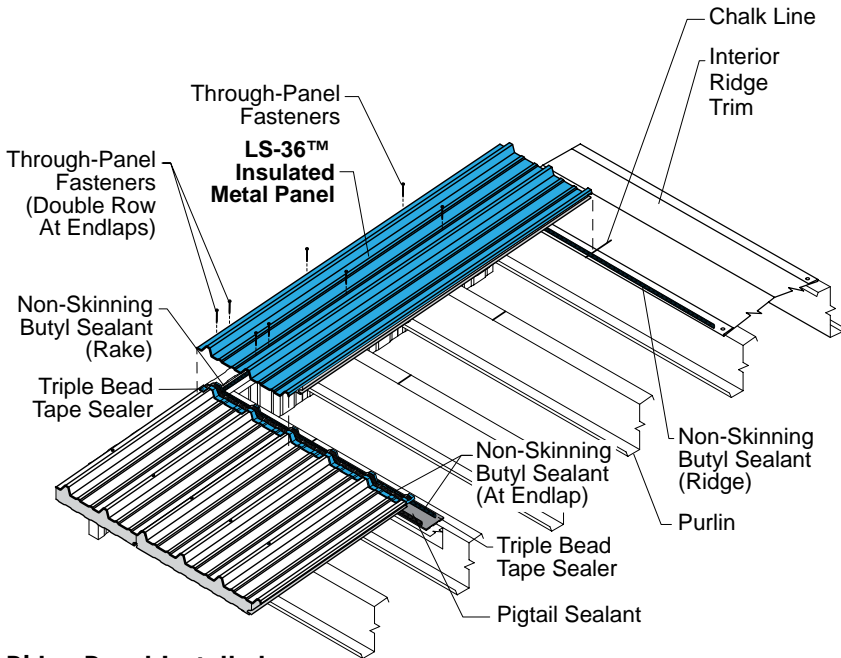

Ridge Panel Installed

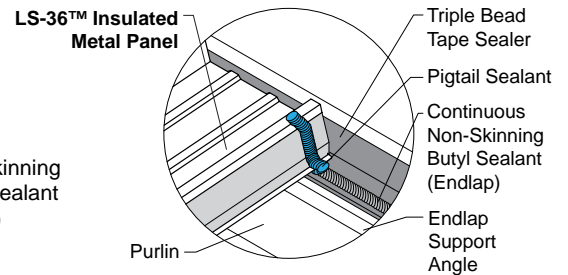

Detail "B"

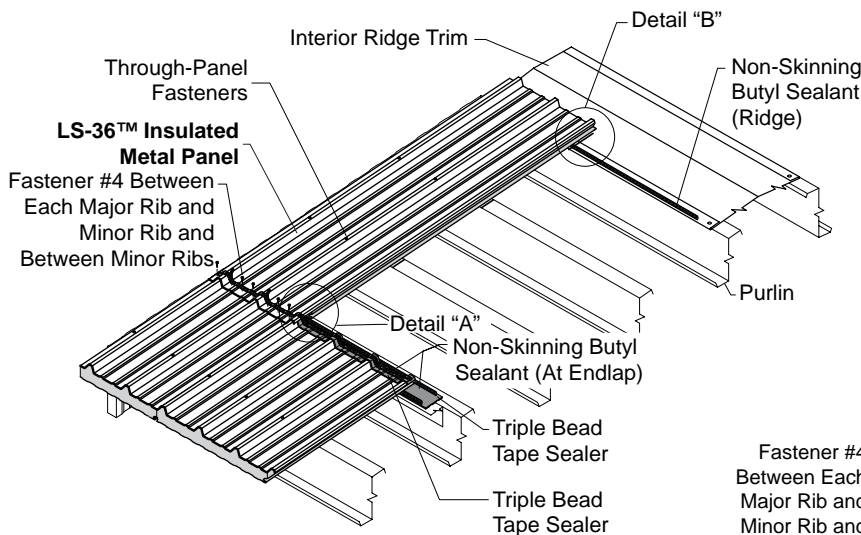

Endlap Panel Attachment

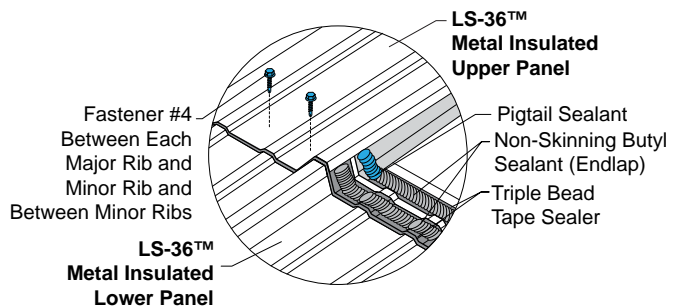

Detail "A"

**STEP
7**

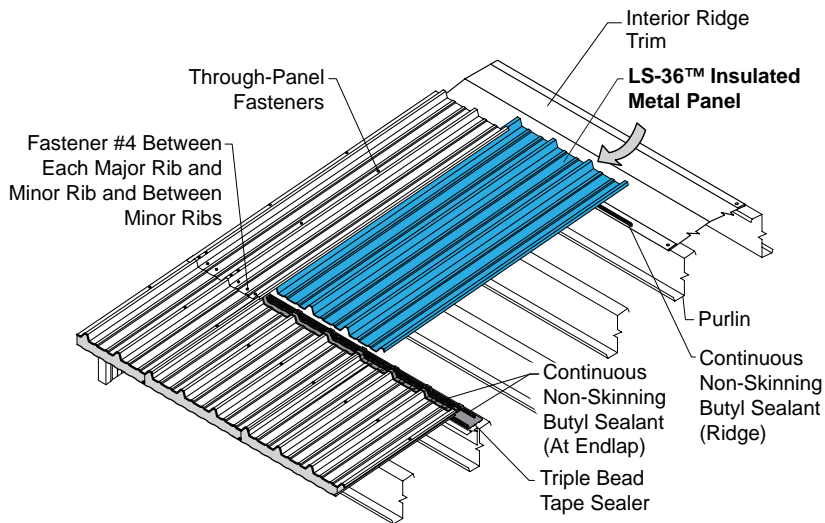
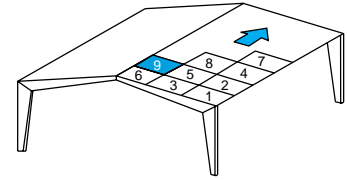

Subsequent Runs Ridge Panel

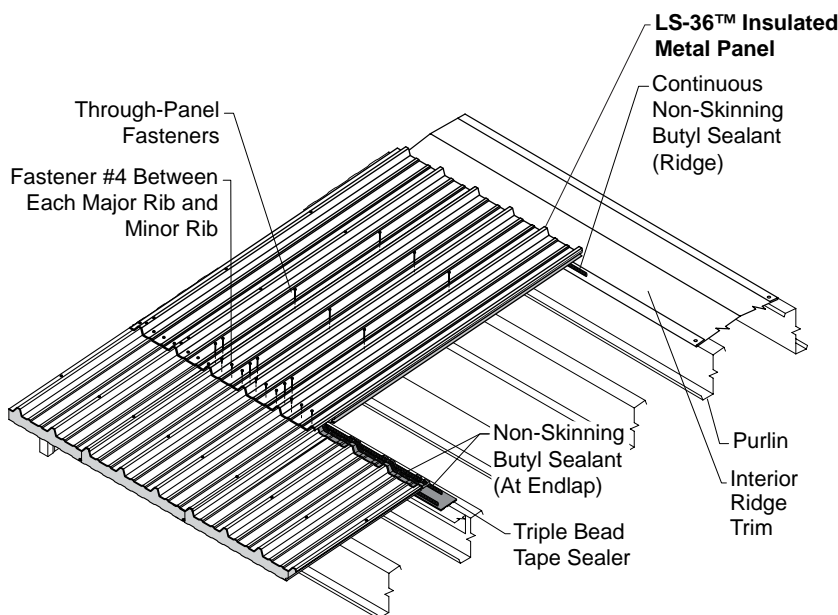

Subsequent Runs Ridge Panel Fastened

**SUBSEQUENT
RUNS-RIDGE**

Apply sealants at the endlap as described in **Step 4**.

Install panel as described in **Step 6**.

Check to ensure that the panel tongue is fully engaged into the previous panel's groove. Install the endlap fasteners as previously described in **Step 5**.

Install panel fasteners at structurals as previously described.

Continue the installation process as described until the last panel run is reached.

**STEP
8**

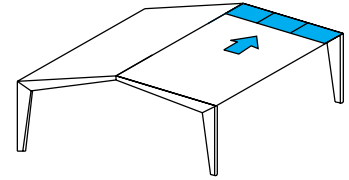

LAST PANEL RUN

When the last panel run is reached, you will need to measure and cut the panel(s) for the proper width. Measure to the face of the end wall panel. Subtract one inch from this measurement to arrive at the width the last panel should be cut. Take this measurement at the eave, all endlaps and the ridge. If the measurements are different at each location, mark them on the appropriate end of each panel and taper cut the panel to provide proper coverage at each location.

Apply non-skinning butyl sealant along the rake angle and all pigtail sealants.

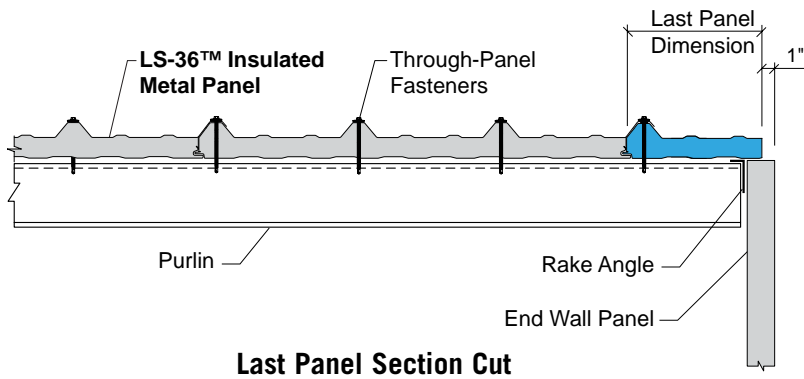

Last Panel Section Cut

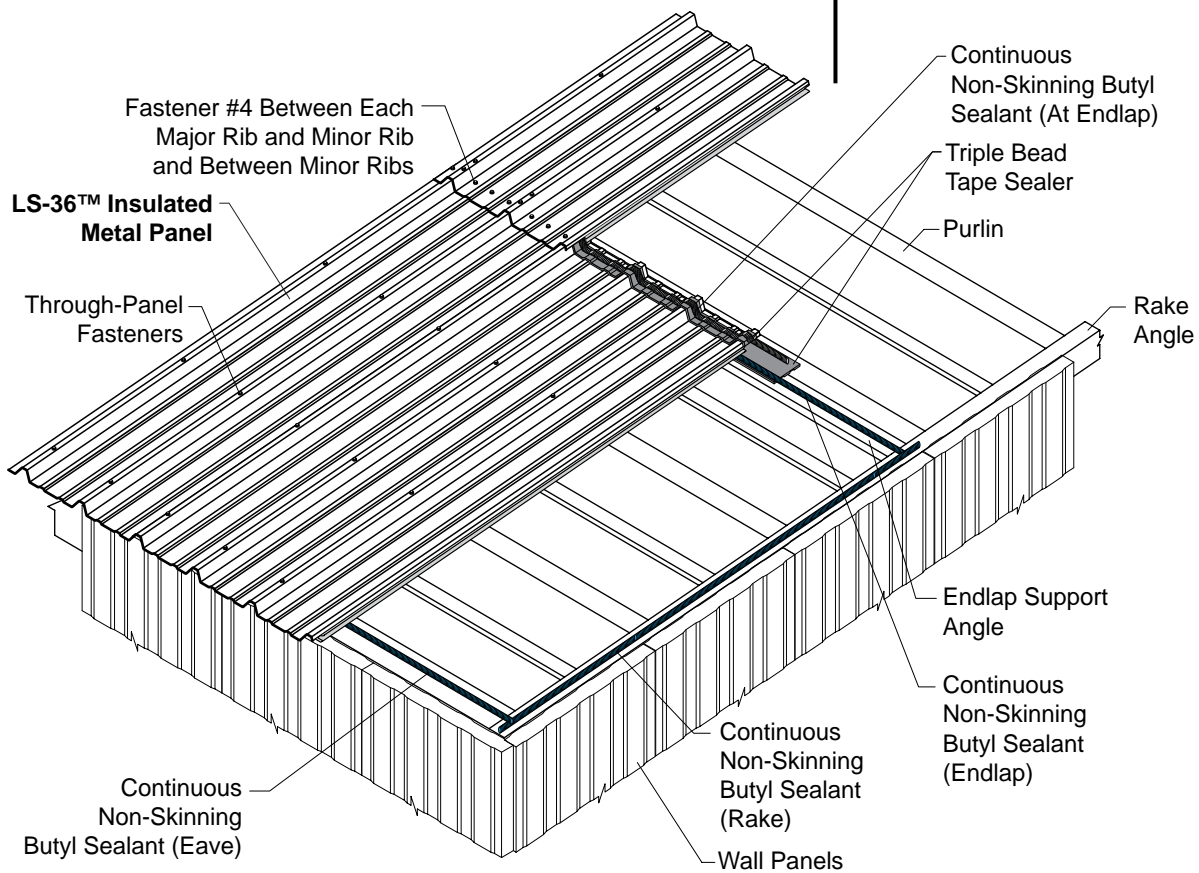

Last Panel Run Sealant Detail

**STEP
8
CONT'D.**

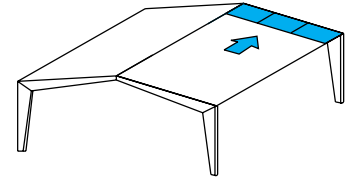

**LAST PANEL RUN
(continued)**

Install each panel as previously described. At the rake edge of this panel run, the panels will be fastened to the structure with temporary self-drilling fasteners installed through the panel and into the rake angle. Permanent fasteners will be installed with the rake zee.

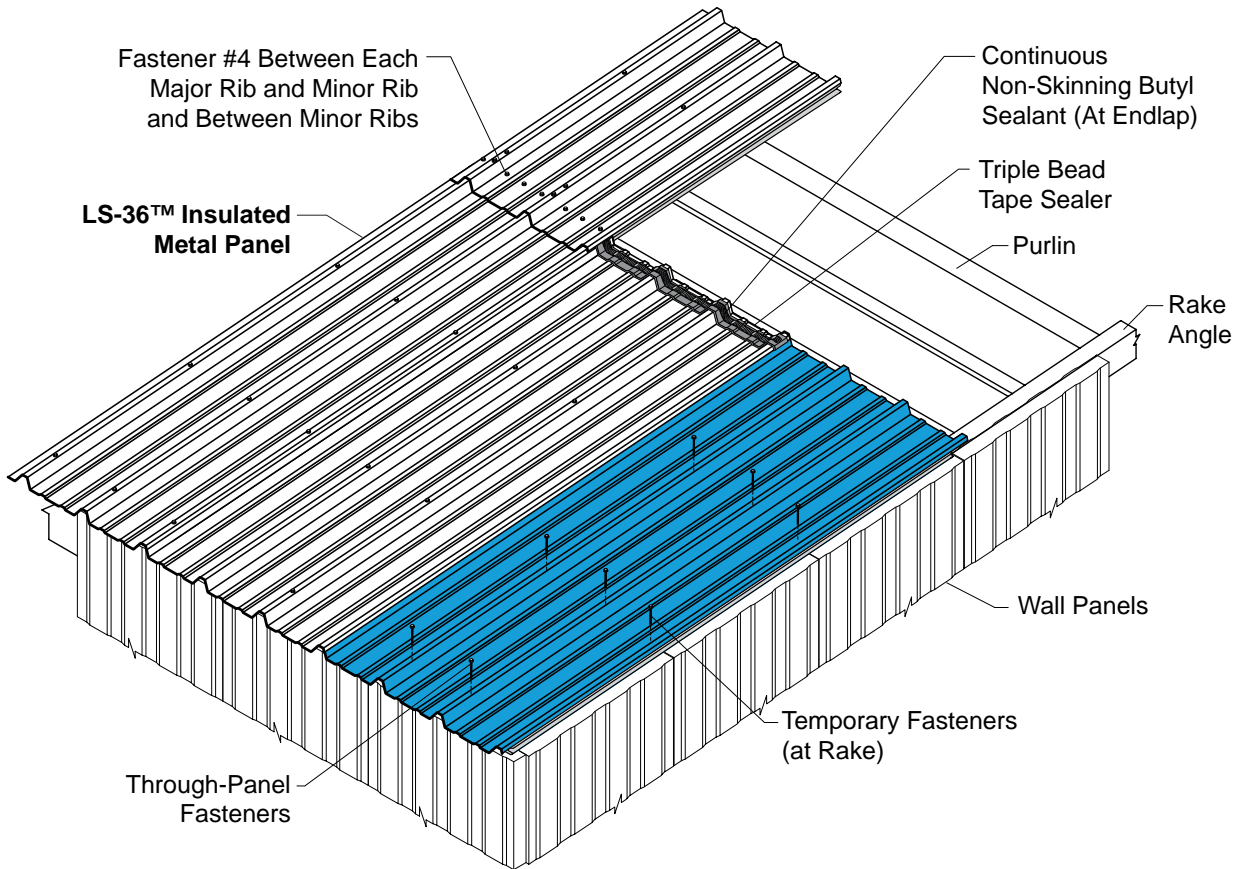

Last Panel Installed

**STEP
9**

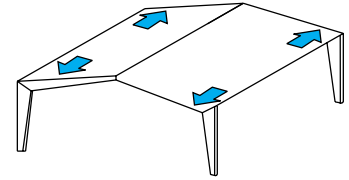

RAKE ZEE INSTALLATION

At the rake, remove the temporary fasteners installed to hold the first and last panels to the substructure. Pop a chalk line from eave to ridge that centers over the holes left by the removal of these fasteners. Apply 1" x 1/8" tape sealant along the rake centered over the chalk line and covering the fastener holes.

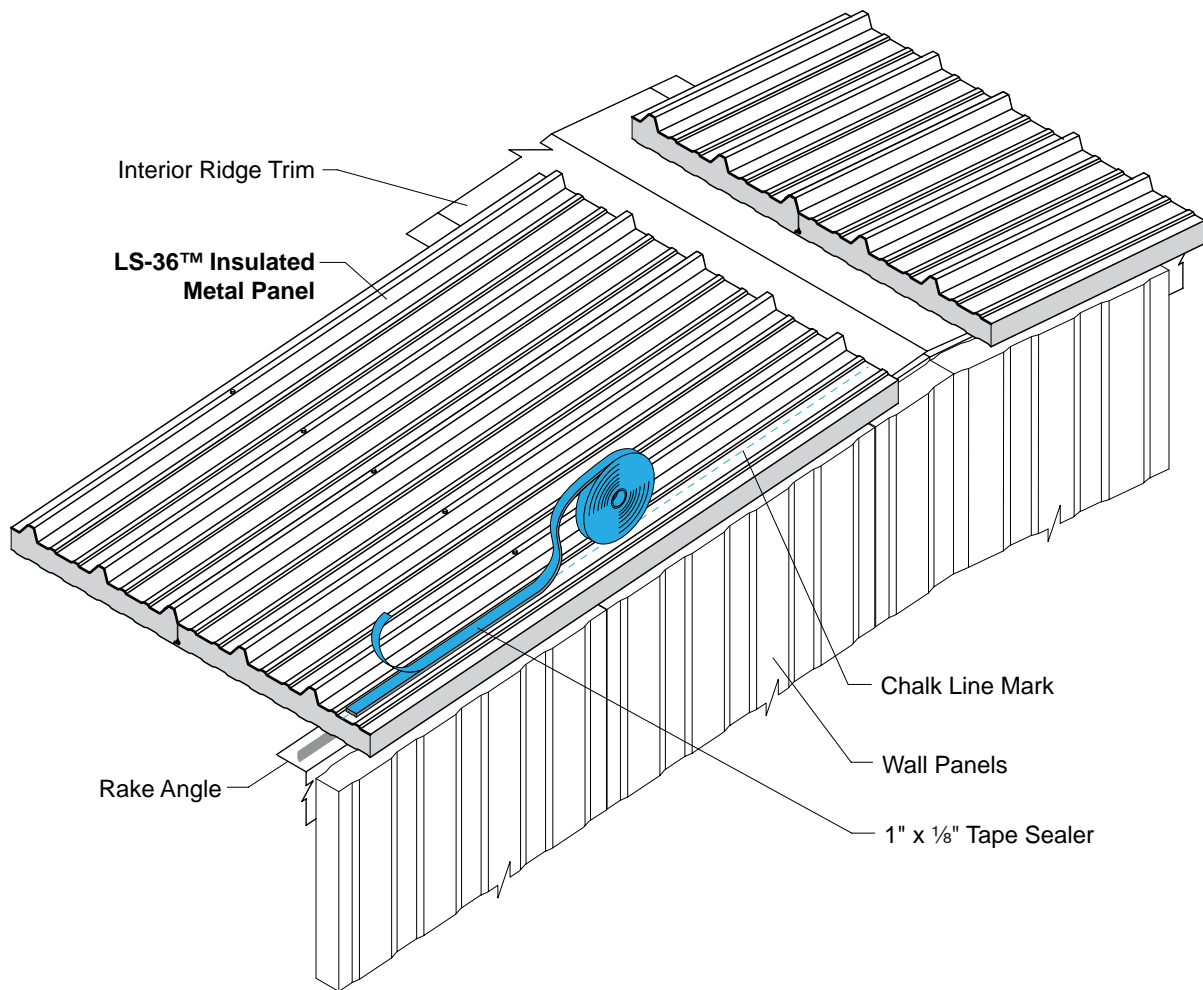

Rake Zee Installation of Tape Sealant

**STEP
9
CONT'D.**

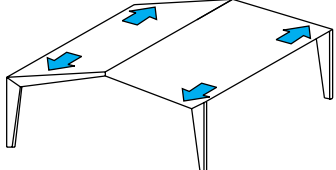

**RAKE ZEE INSTALLATION
(continued)**

Install rake zeos beginning at the ridge and working toward the eave. Rake zee should start and finish at the panel ends. Fasten rake zee with through-panel fasteners of the proper length for the panel thickness. Fastener will fasten through the rake angle. Install fasteners a minimum of 12" on center.

Before installing the next rake zee, apply 1" x 1/8" tape sealant along the cross section of the previously installed rake zee and a 2" piece of tape sealant along the top flange. Install the next rake zee, lapping it 2" onto the previously installed rake zee. Install a through-panel fastener at this lap through the bottom flange of the rake zeos and into the rake angle. From the weather side of the rake zee, install Fastener #4 through the rake zee lap to hold the vertical legs tightly together. Continue this process until the last rake zee has been installed at the eave. Cut the last rake zee to fit flush with the eave end of the panel.

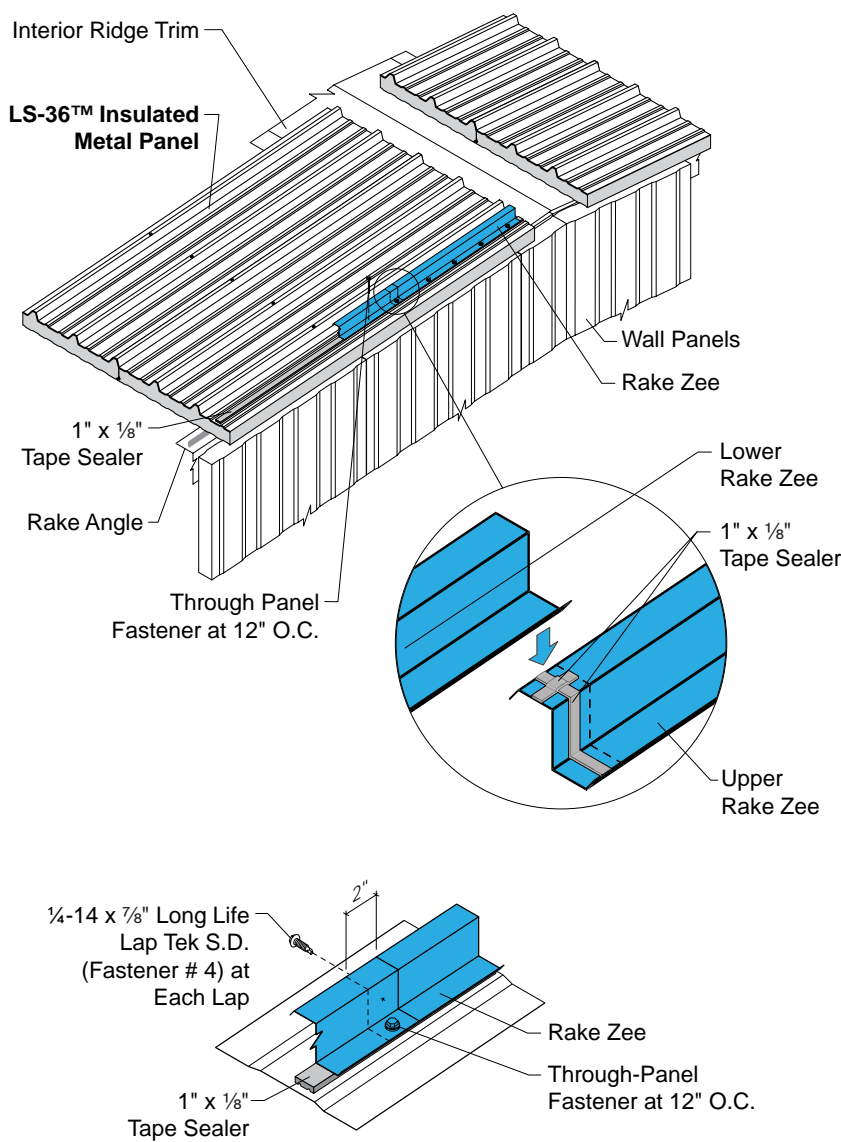

Rake Zee Installation

**STEP
10**

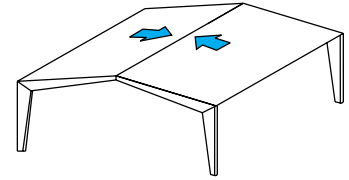

**OUTSIDE CLOSURE
INSTALLATION**

At the ridge, place 1" x 1/8" tape sealant across full width of panels, conforming tape sealant to panel profile. Center of tape sealant should be 1 1/2 inches from end of panels.

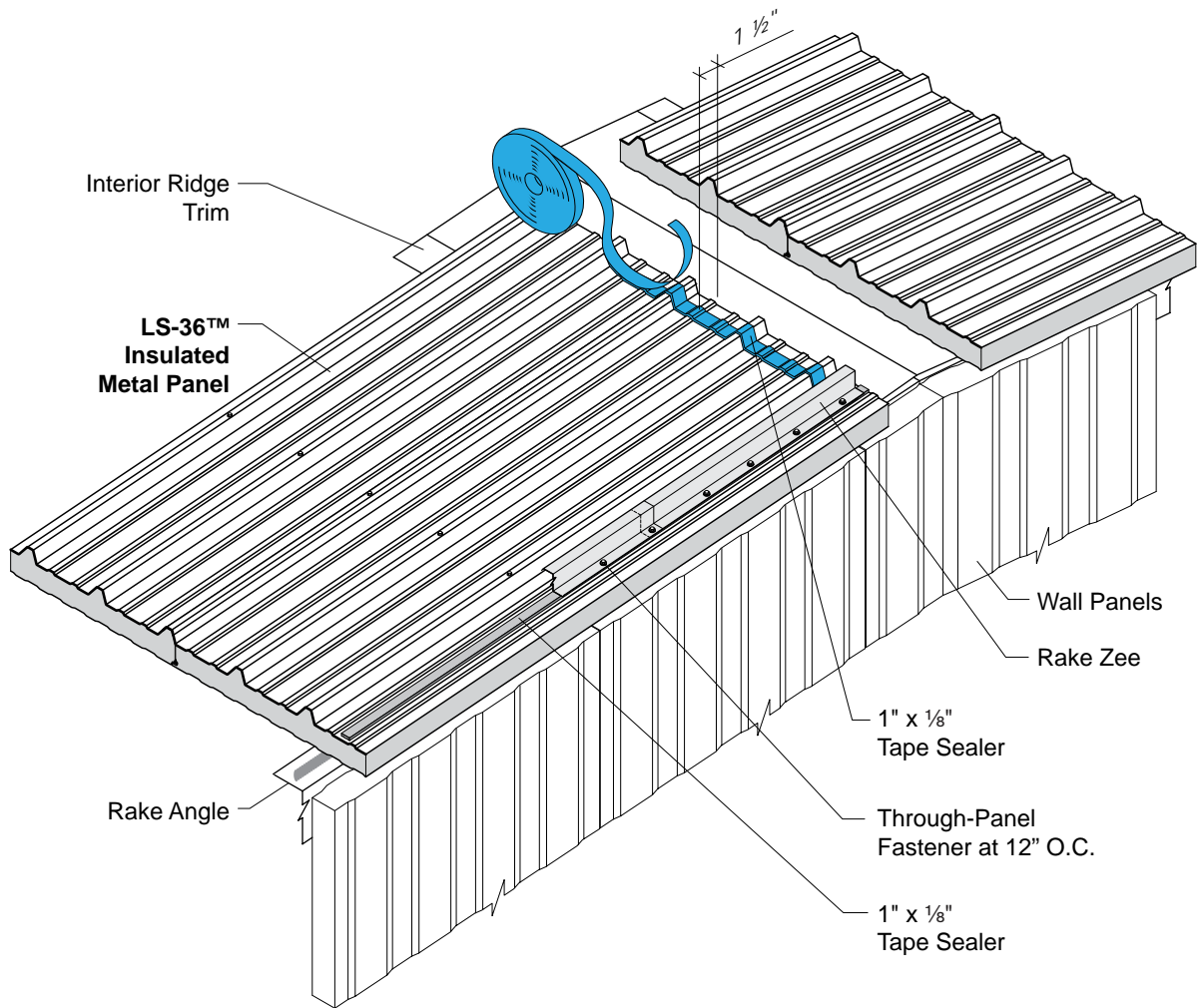

Outside Closure Tape Sealant Installation

INSTALLATION SEQUENCE

LS-36™ INSULATED METAL ROOF & WALL PANEL

**STEP
10
CONT'D.**

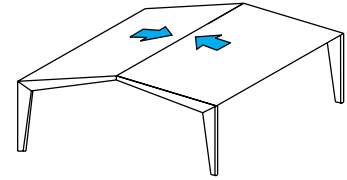

OUTSIDE CLOSURE INSTALLATION (continued)

Install and attach the outside closure to the panel with Fastener #4 at each pre-punched hole in the closure.

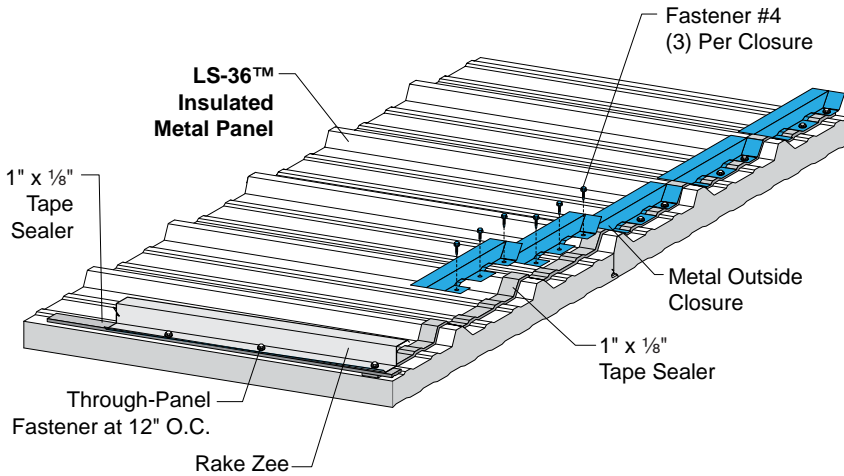

Outside Closure Installation

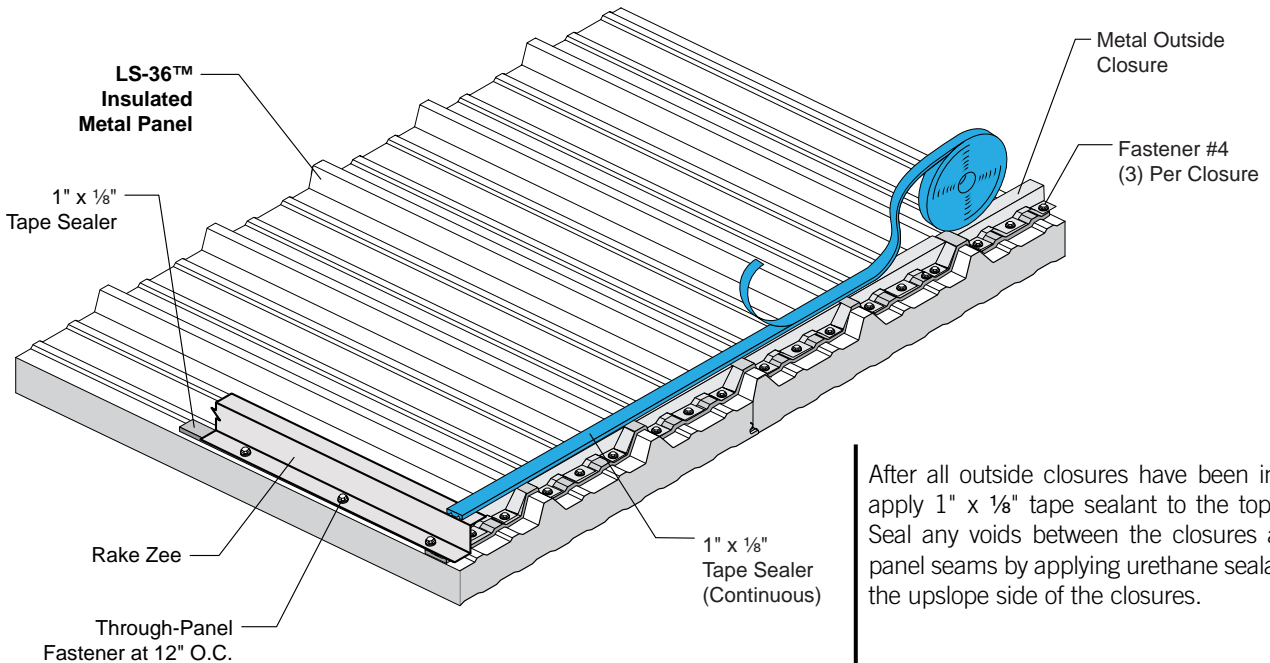

After all outside closures have been installed, apply 1" x 1/8" tape sealant to the top flange. Seal any voids between the closures and the panel seams by applying urethane sealant from the upslope side of the closures.

Outside Closure Installation Final

ROOF DETAILS

LS-36™ INSULATED METAL ROOF & WALL PANEL

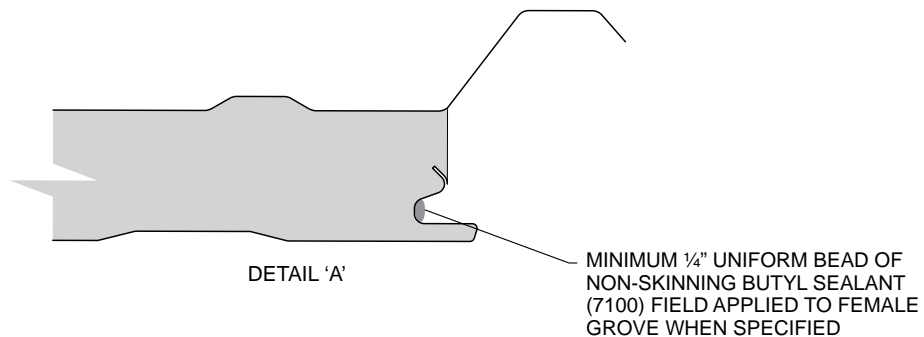
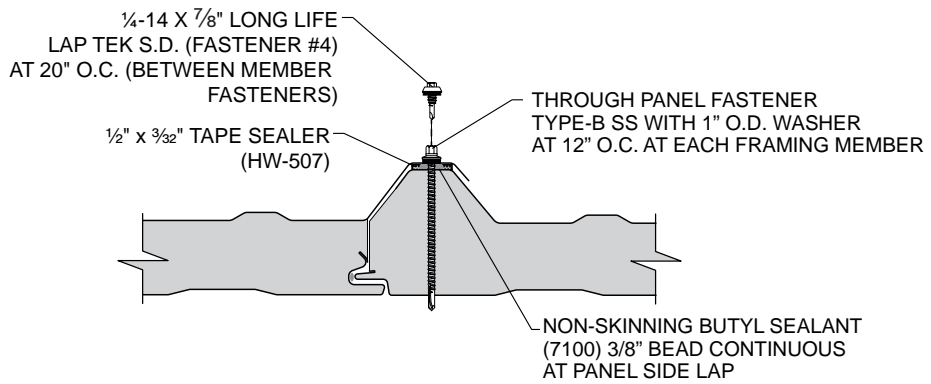
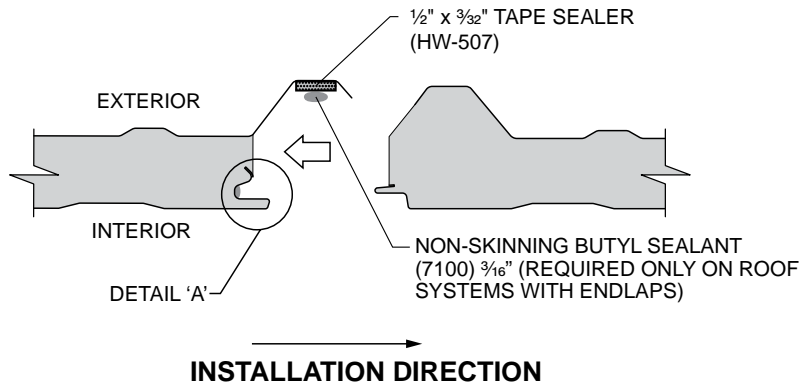
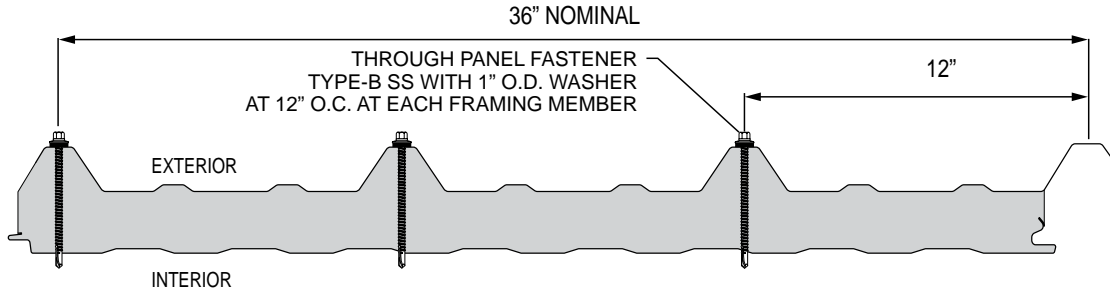

RIDGE

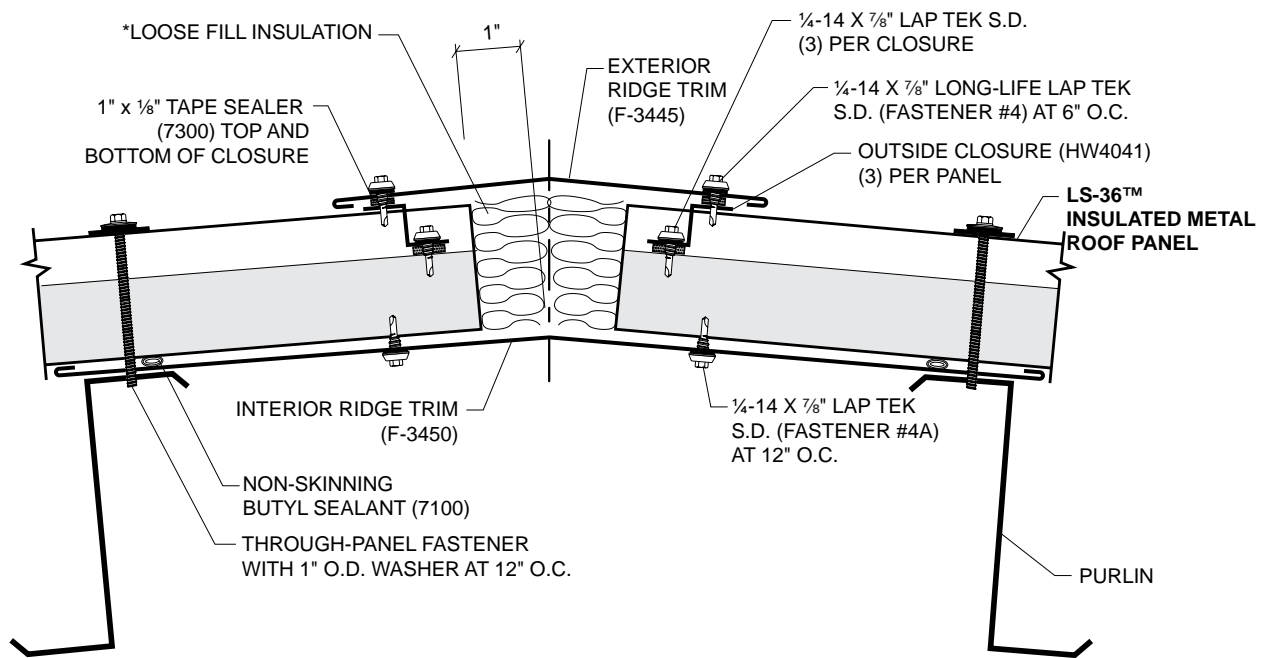

*NOT BY METL-SPAN

PANEL ENDLAP

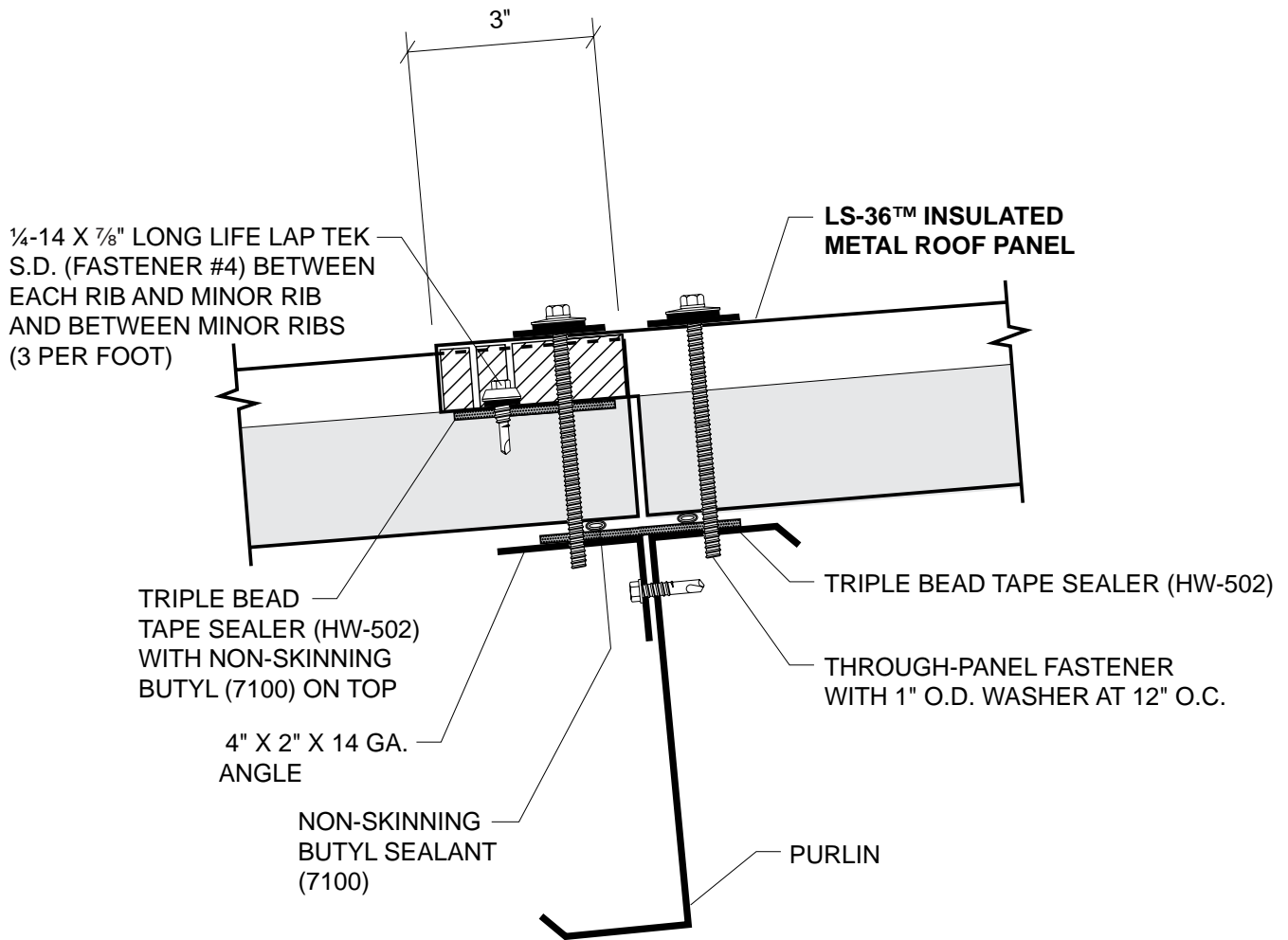

HIGH EAVE

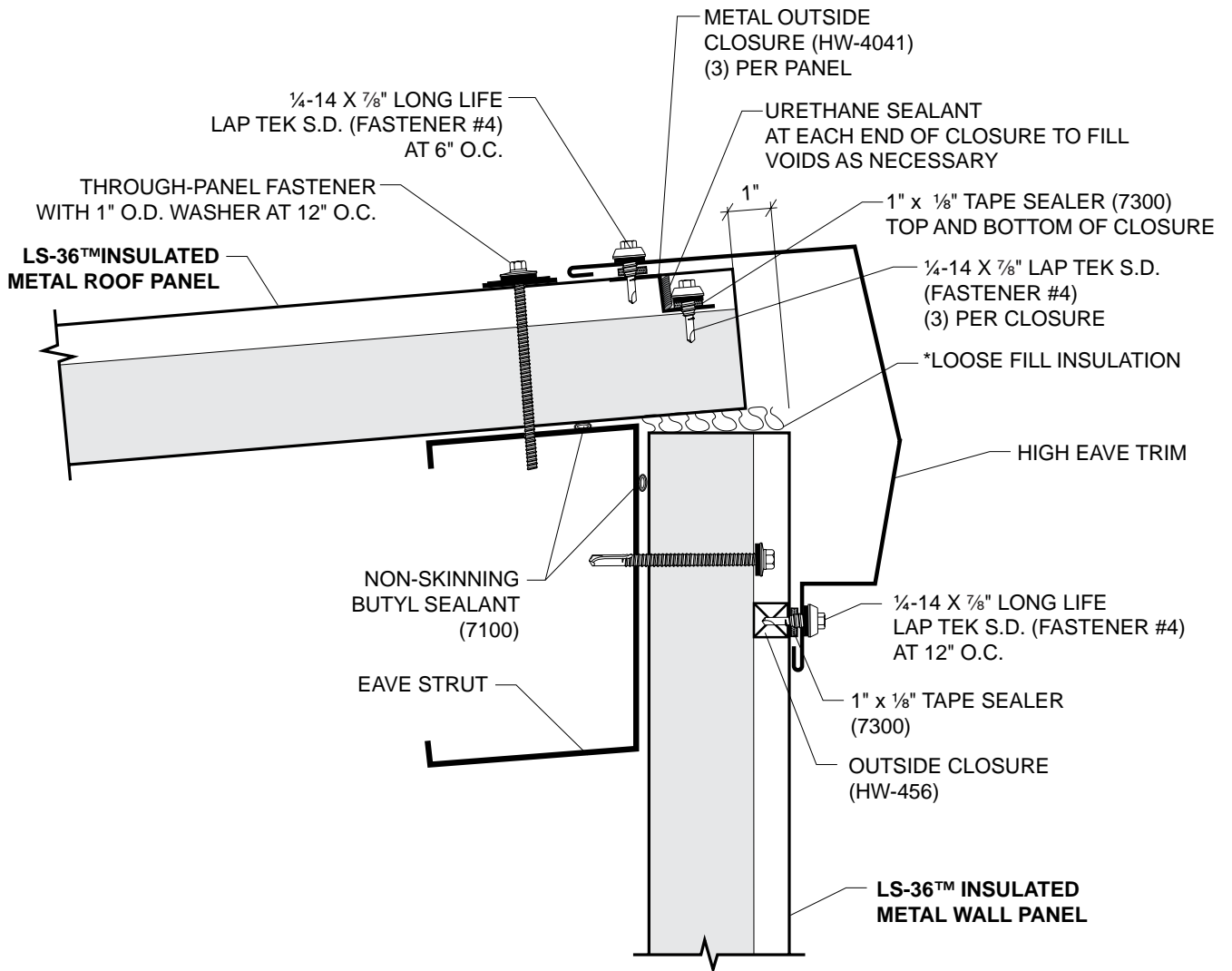

*NOT BY METL-SPAN

EAVE With Eave Trim

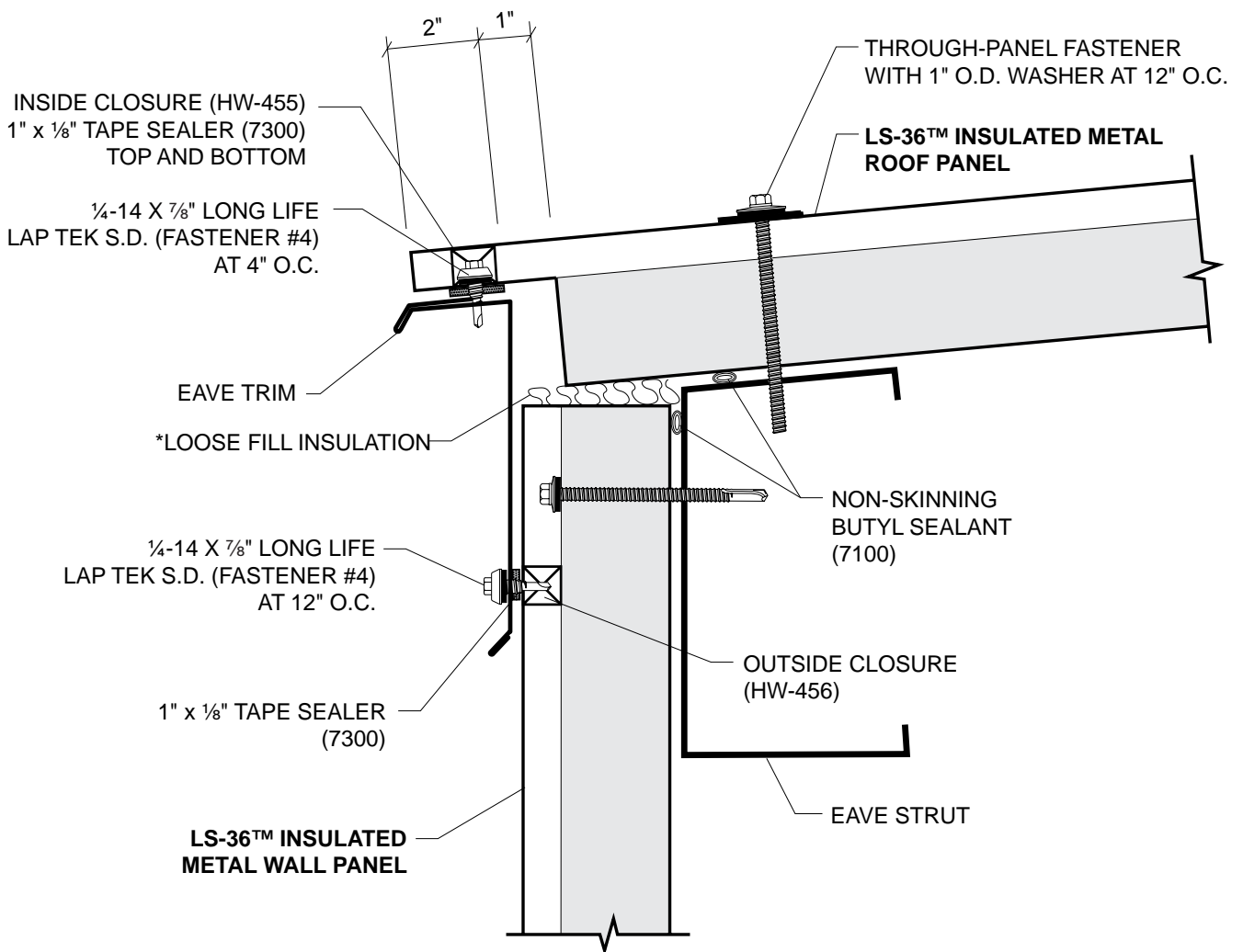

*NOT BY METL-SPAN

EAVE With Gutter

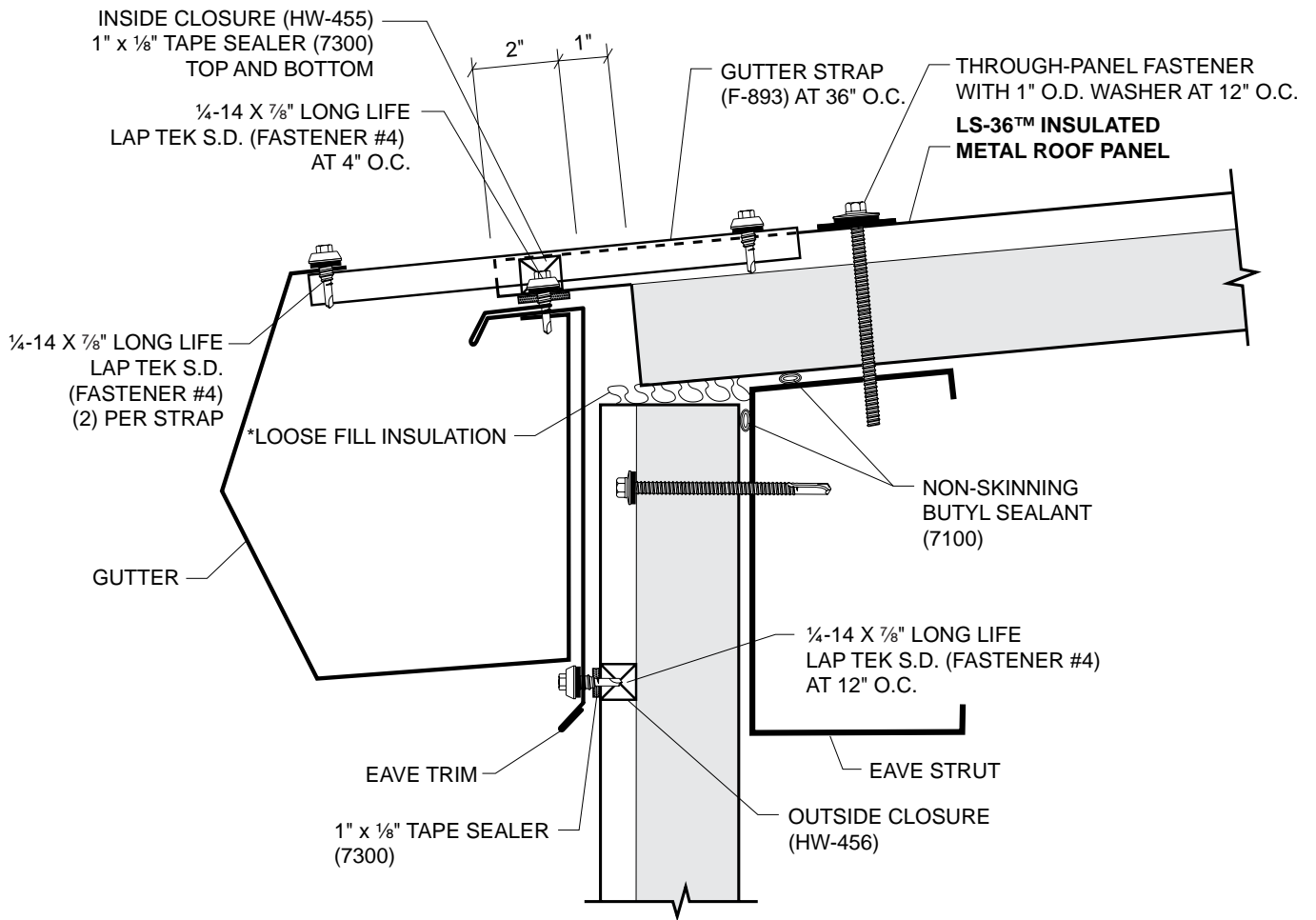

*NOT BY METL-SPAN

RAKE

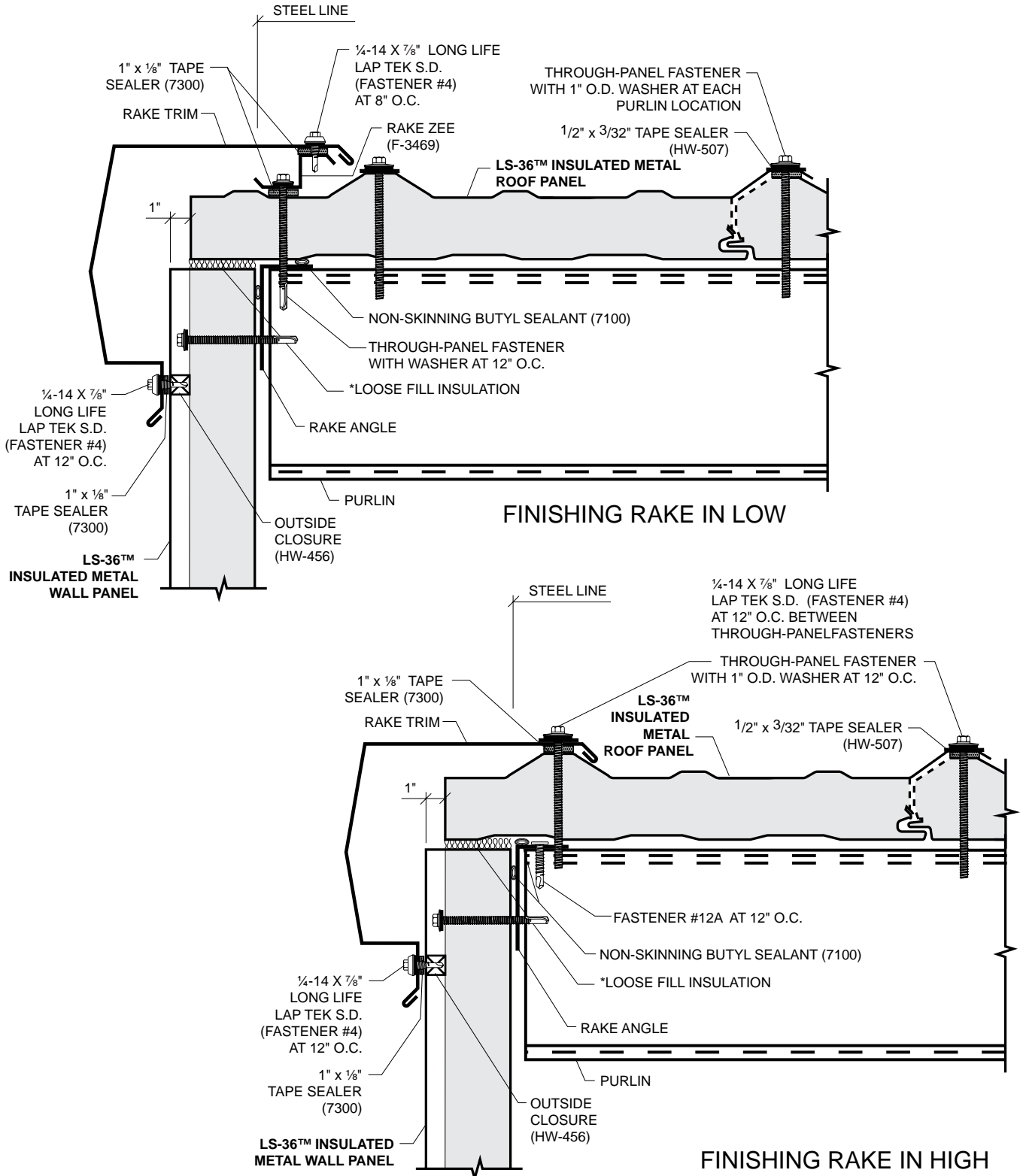

*NOT BY METL-SPAN

PARAPET HIGH EAVE

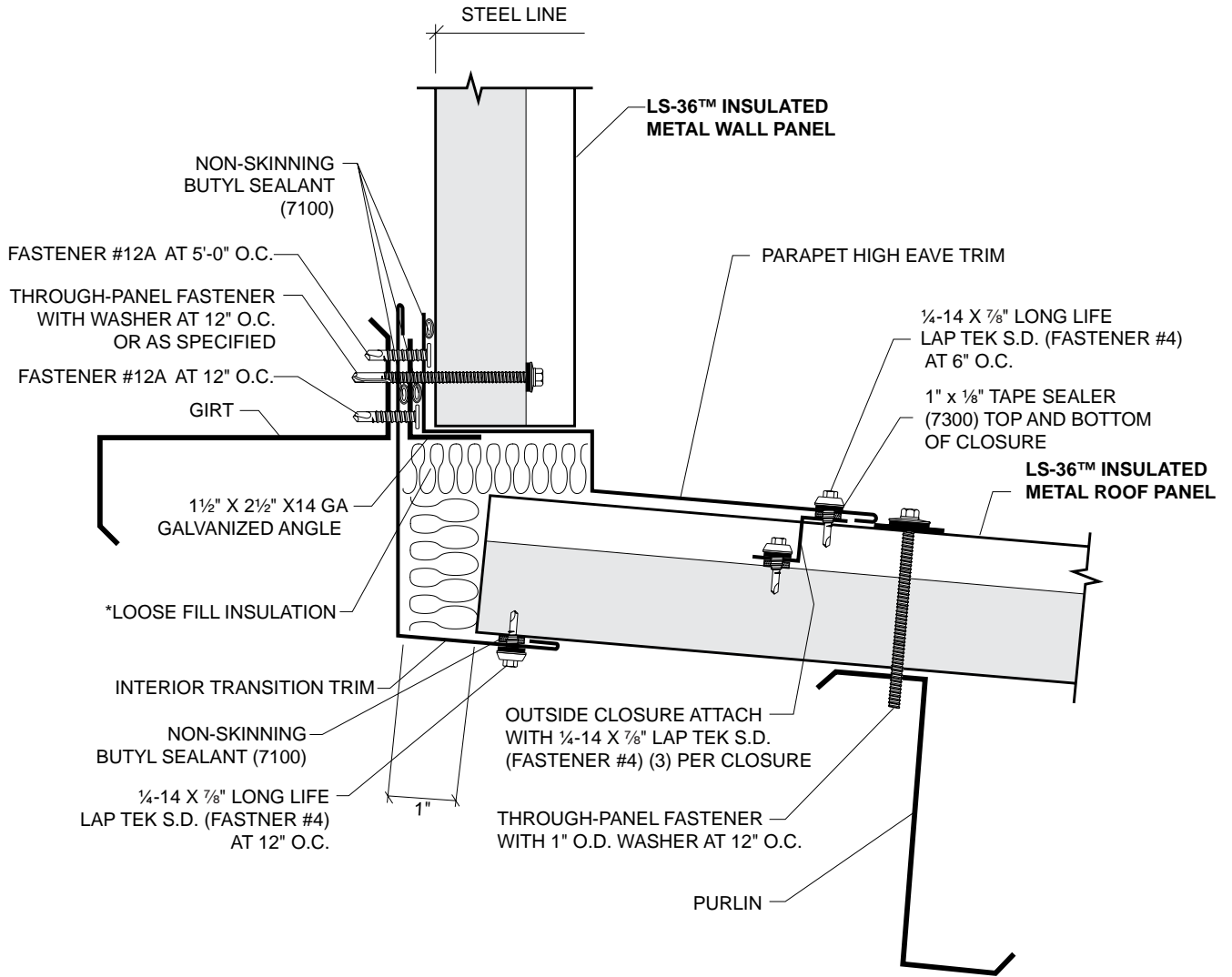

*NOT BY METL-SPAN

PARAPET RAKE

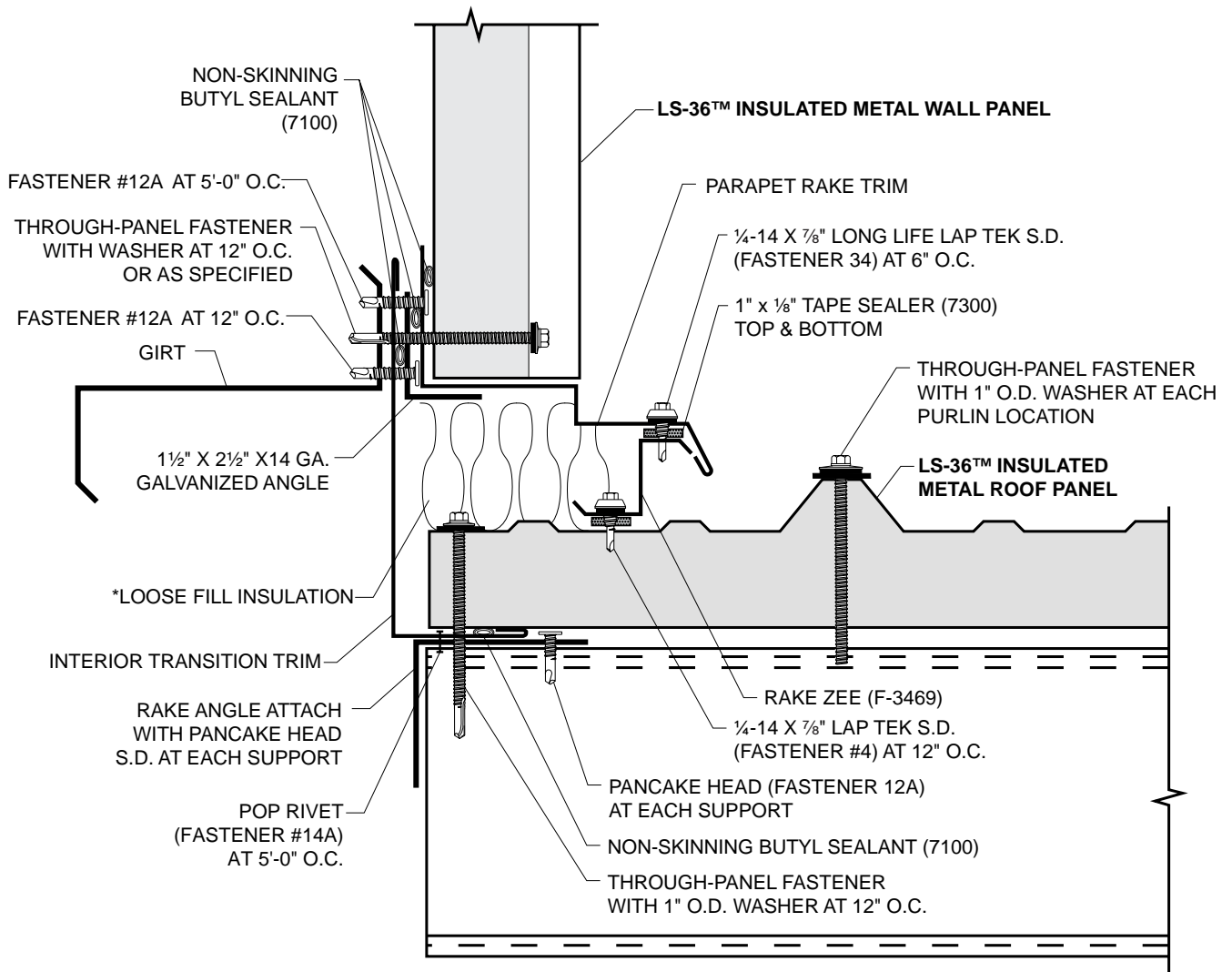

*NOT BY METL-SPAN

ROOF DETAILS

LS-36™ INSULATED METAL ROOF & WALL PANEL

HIP

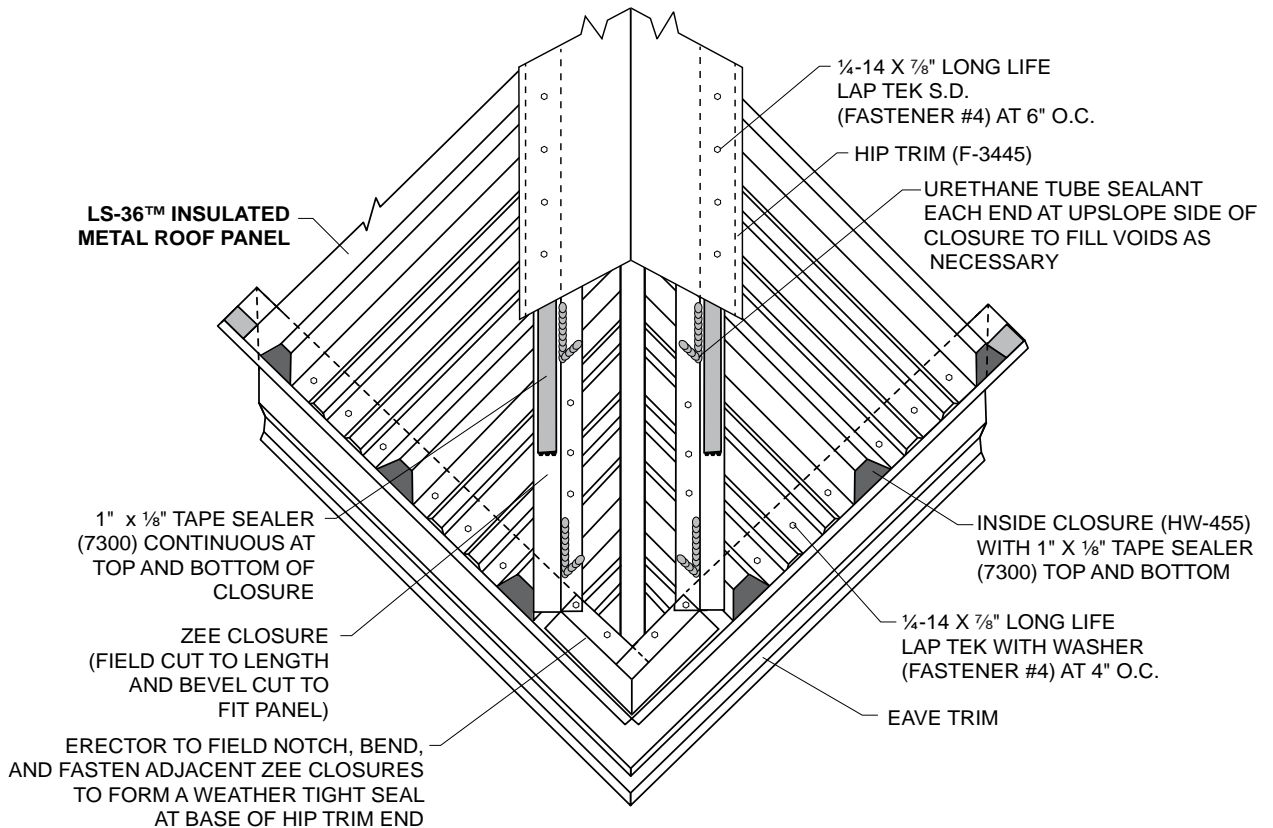
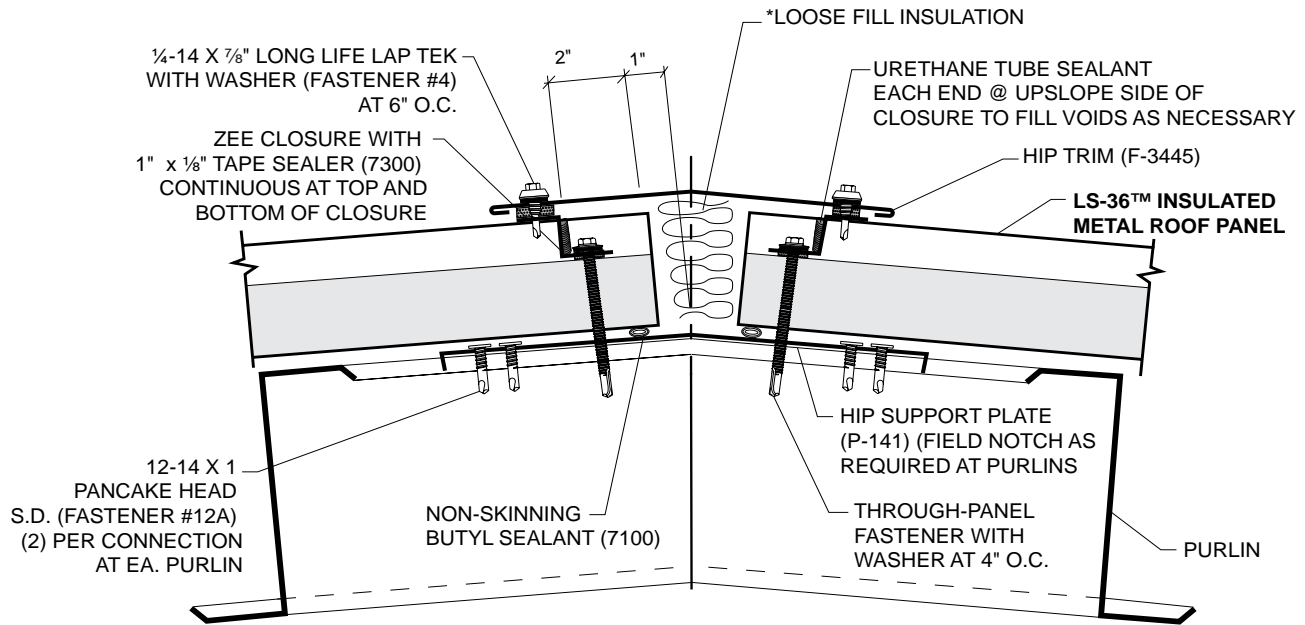

***NOT BY METL-SPAN**

VALLEY

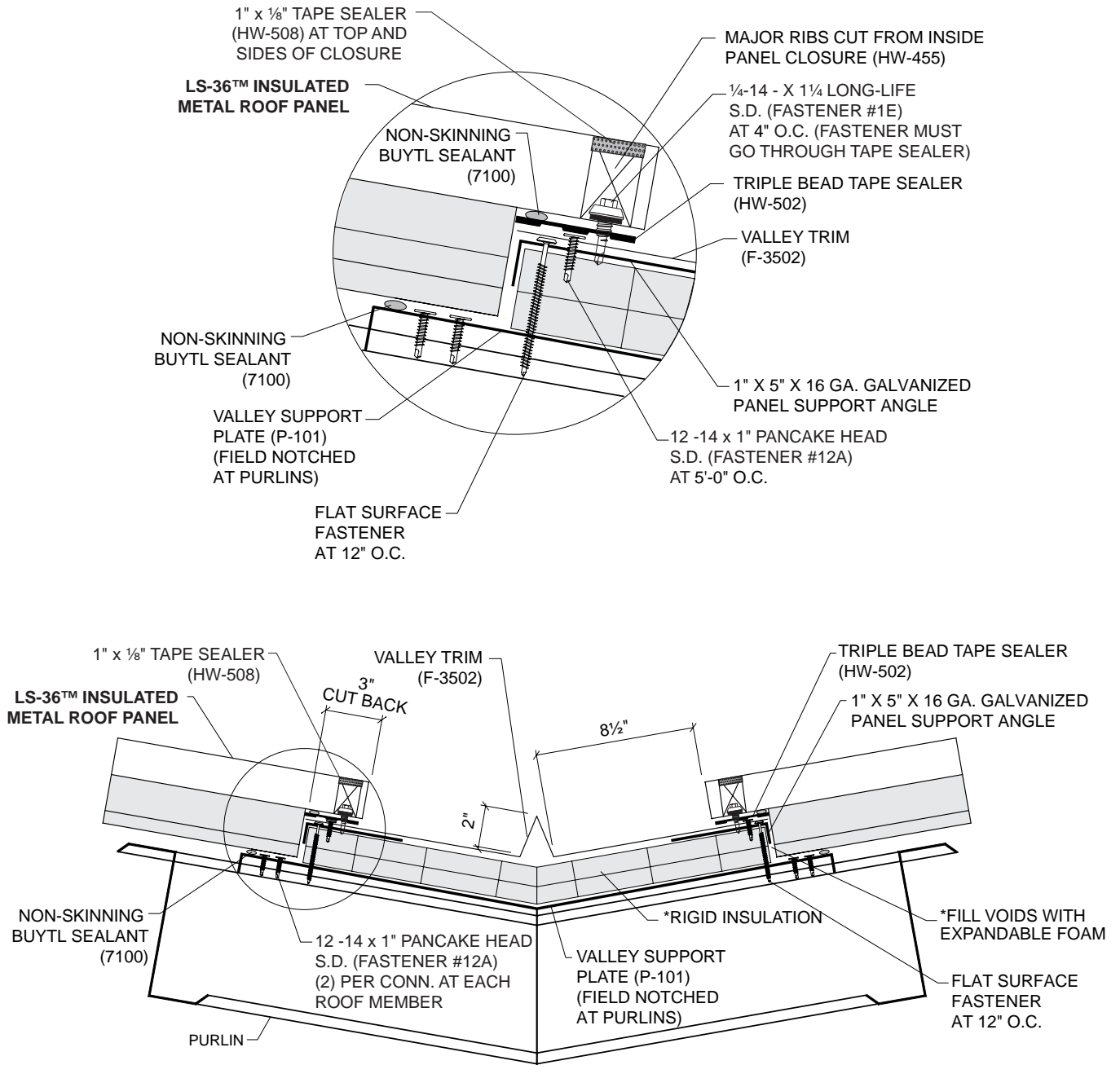

*NOT BY METL-SPAN

NOTES



For the most current information available, visit our website at www.cecobuildings.com | 1-800-474-CECO

